

# Representação Digital

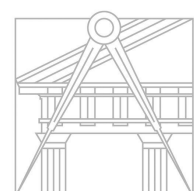

20231238

PAULO SILVA



# ÍNDICE

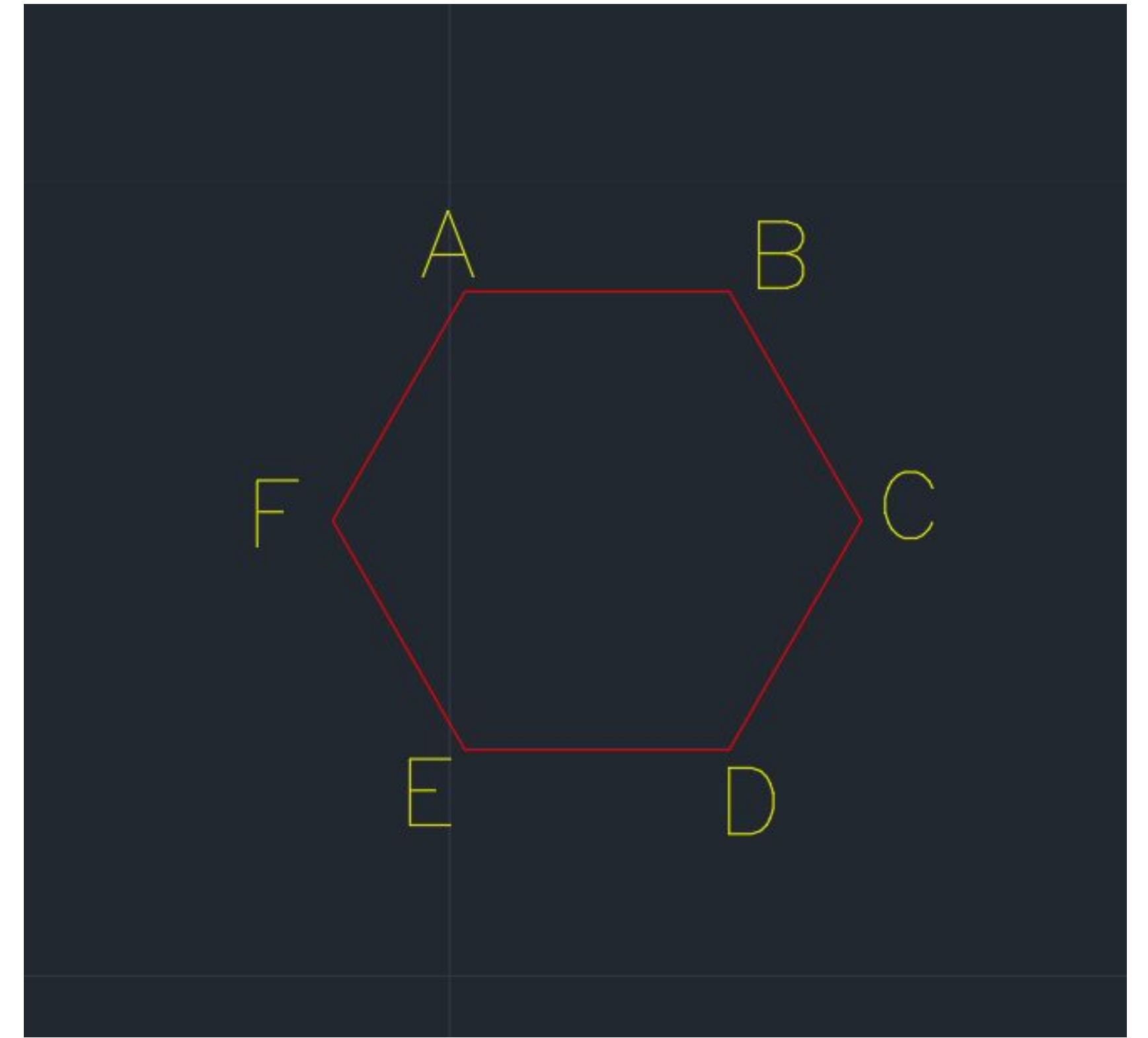
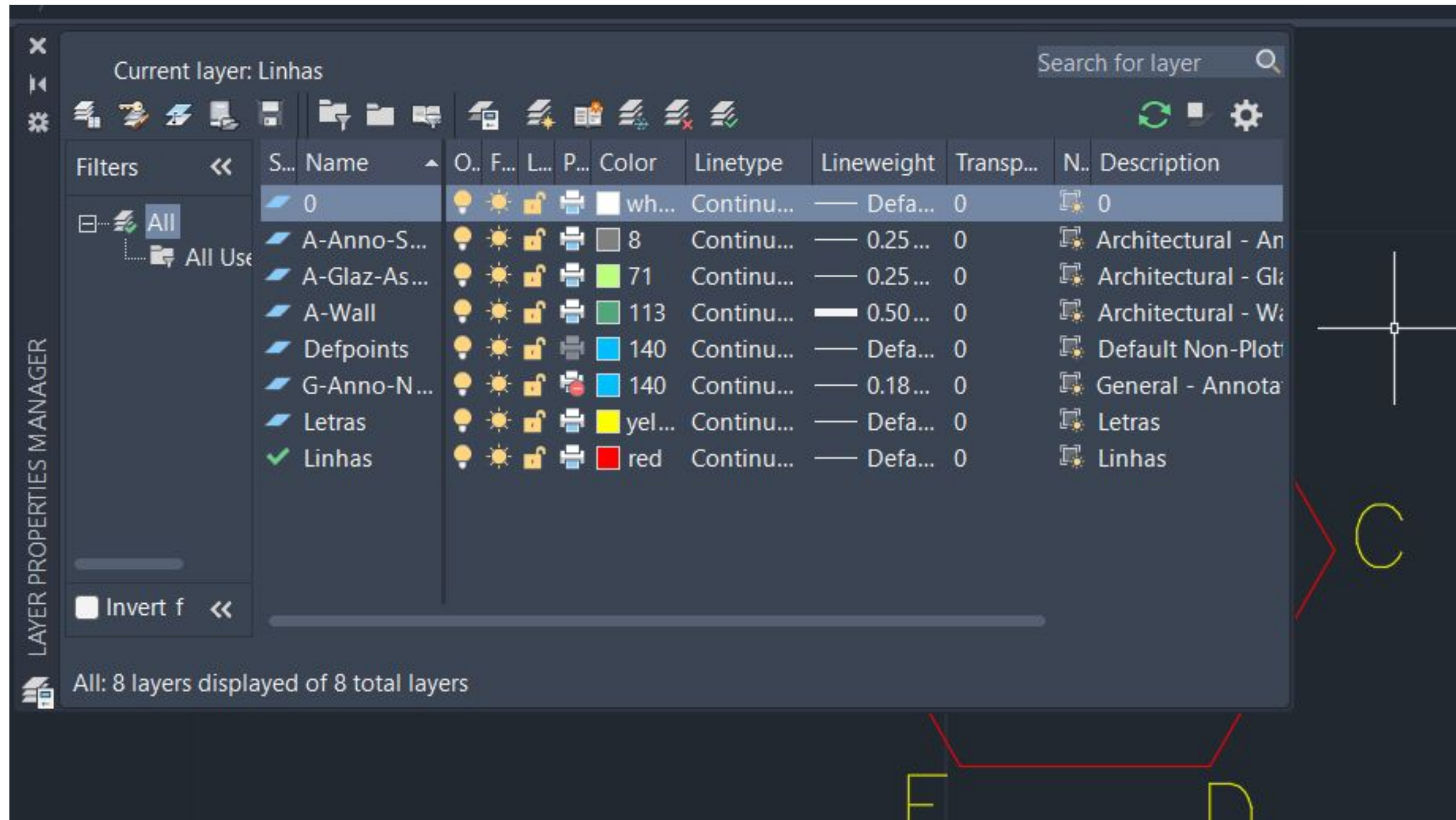

# Aula. 1.1 - Pontos/Layers/Letras

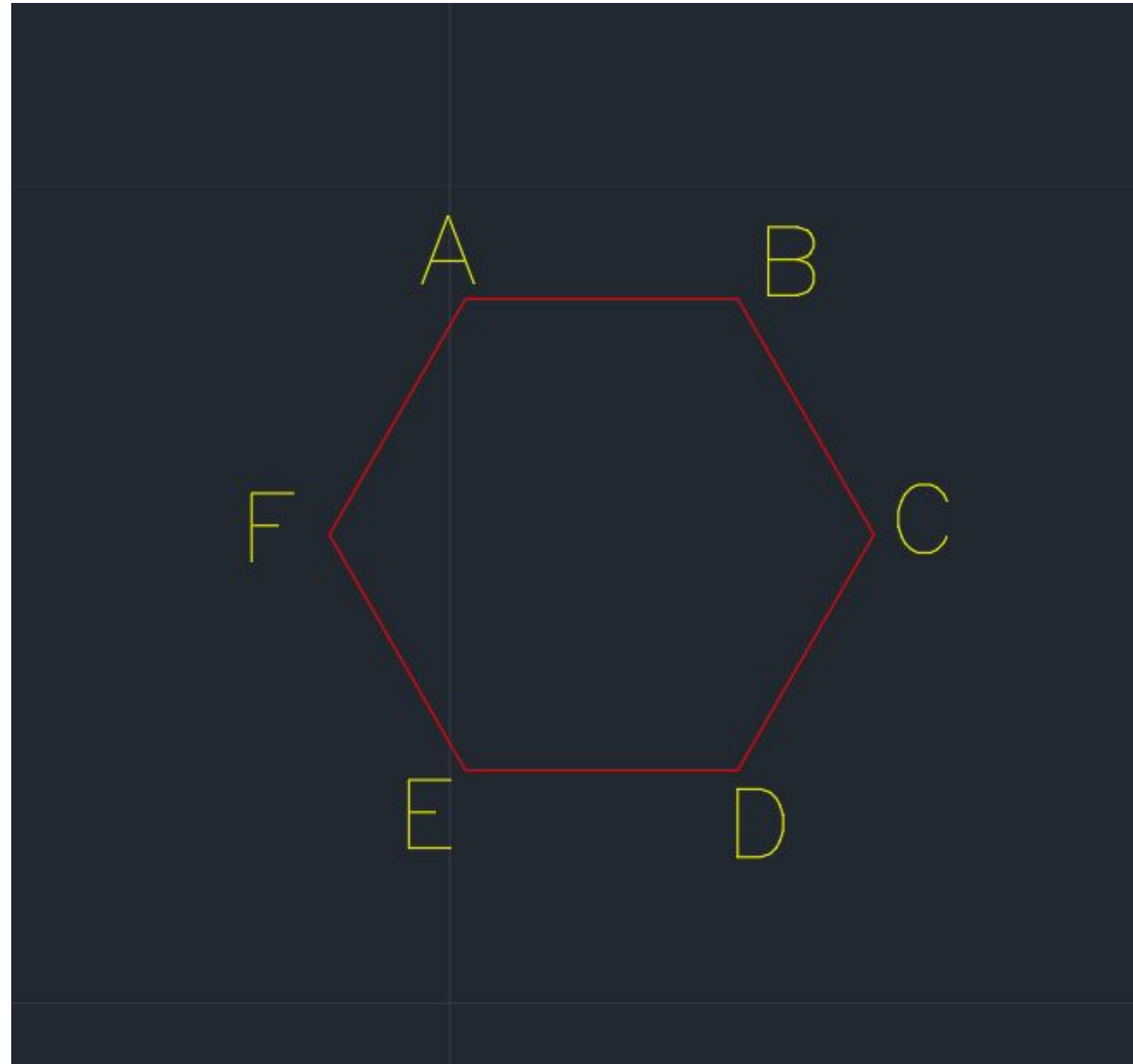

Exerc. 1.1 - Hexágono

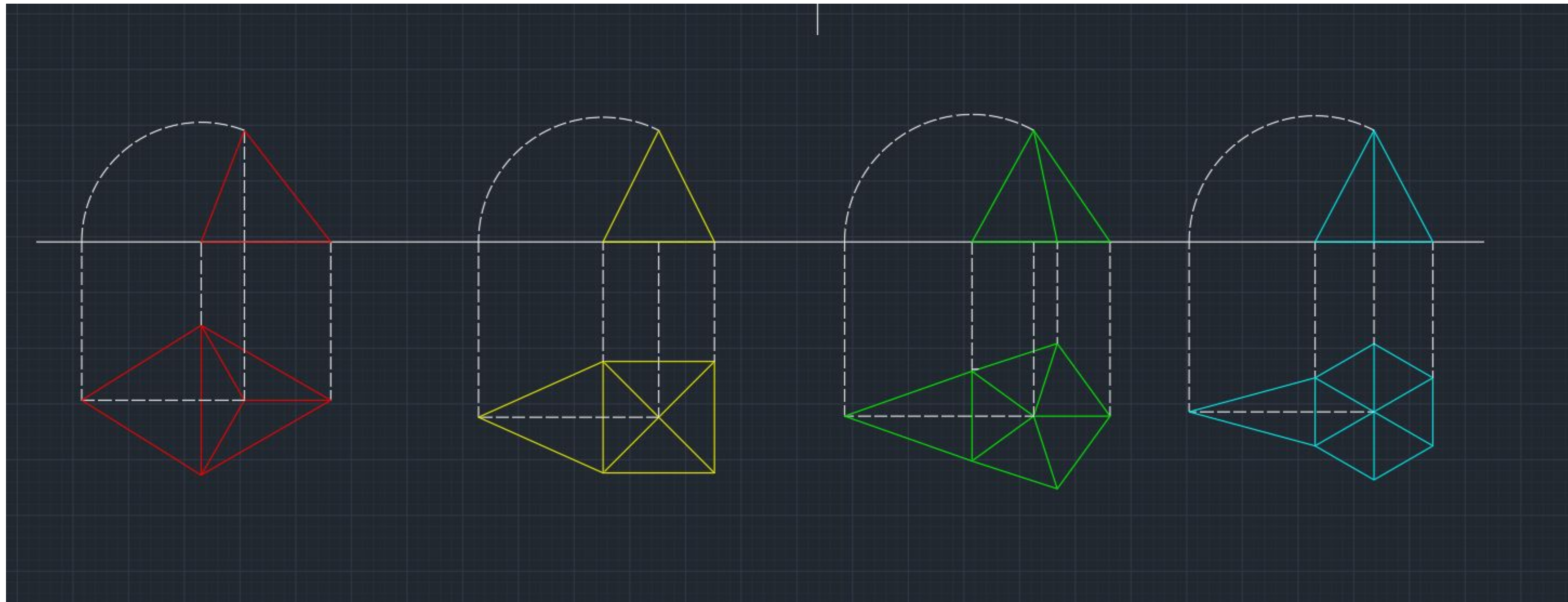

Aula. 2.1 - Verdadeira grandeza/projeção

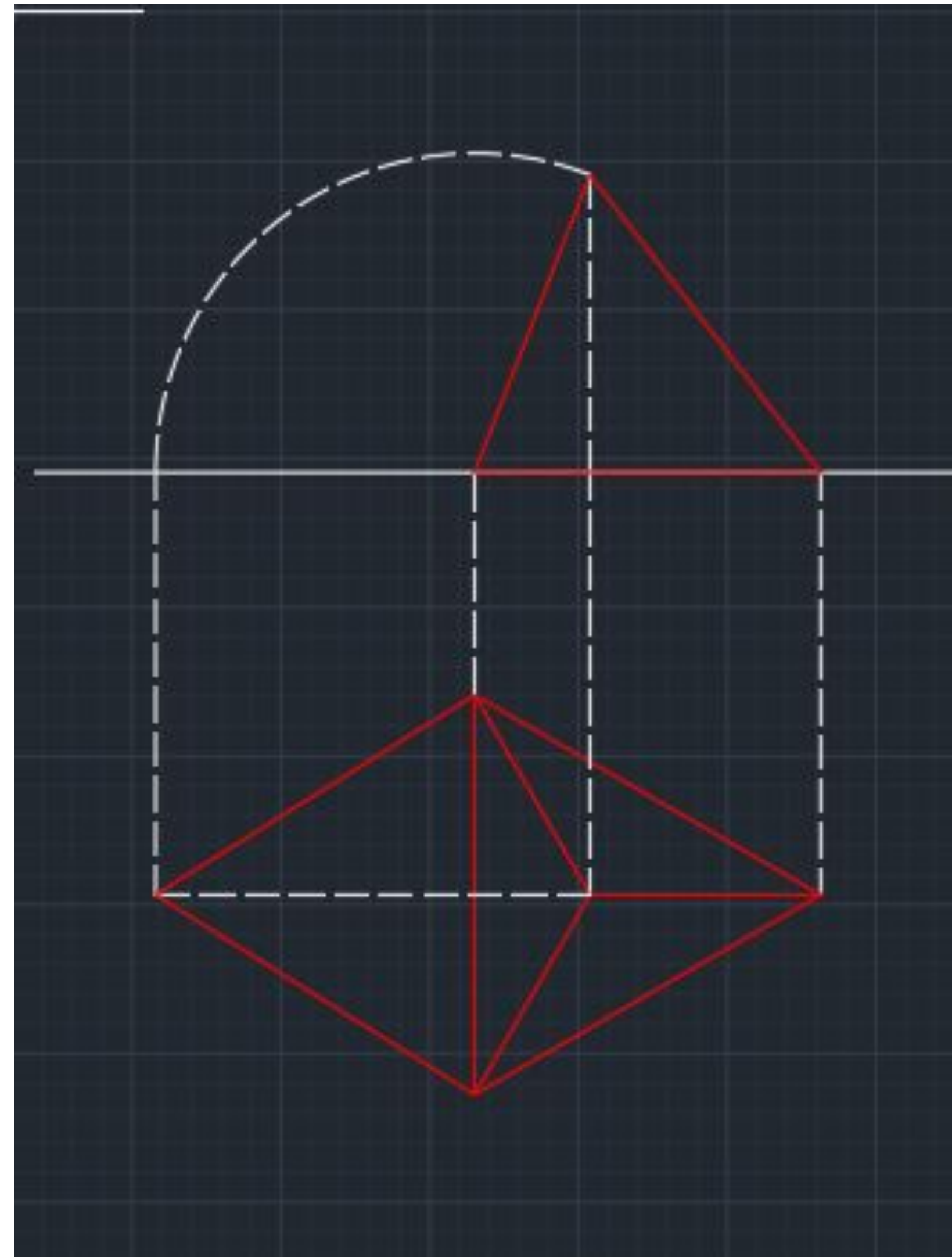

Exerc. 2.1 - pirâmide Triangular

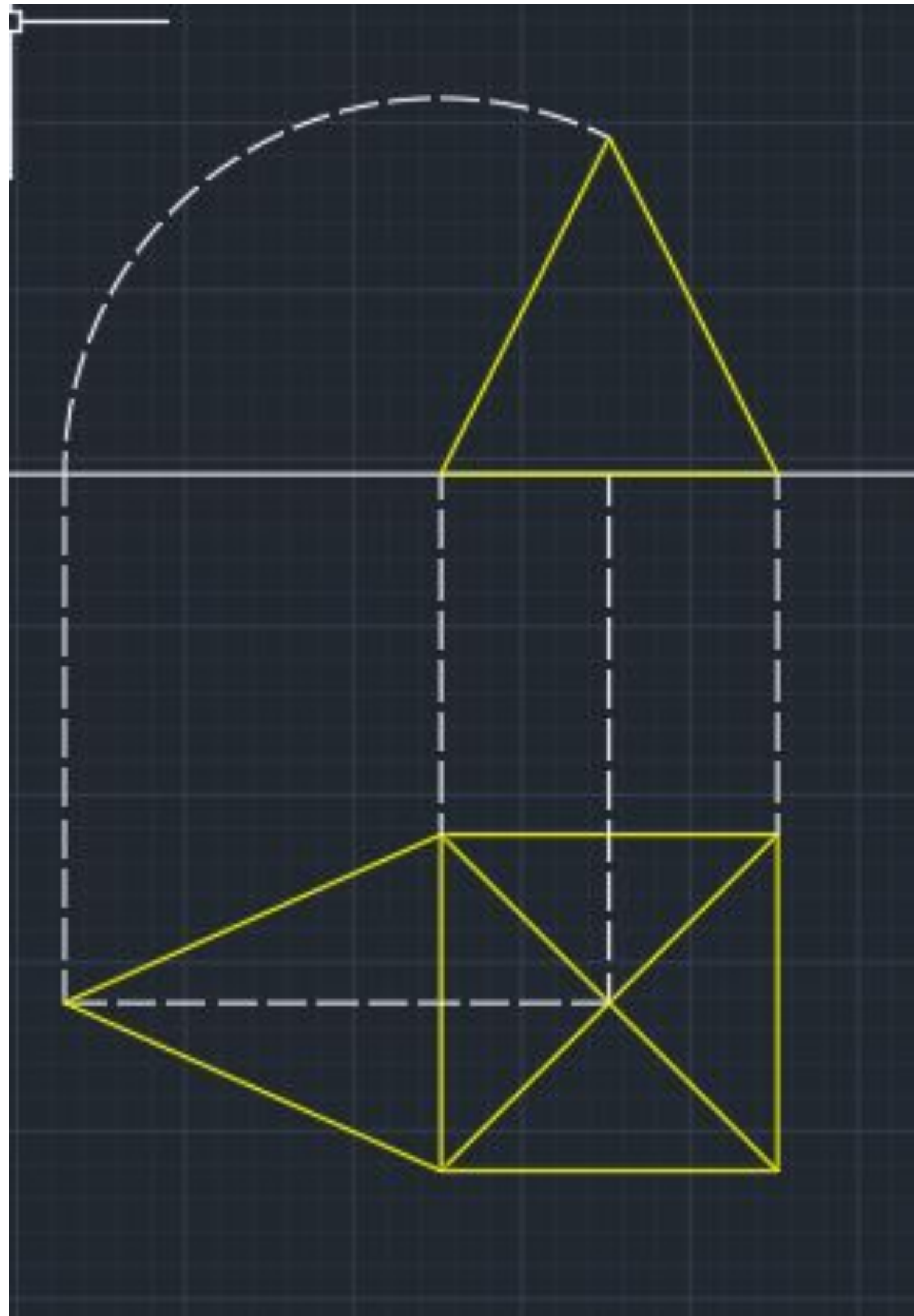

Exerc. 2.2 - pirâmide Quadrangular



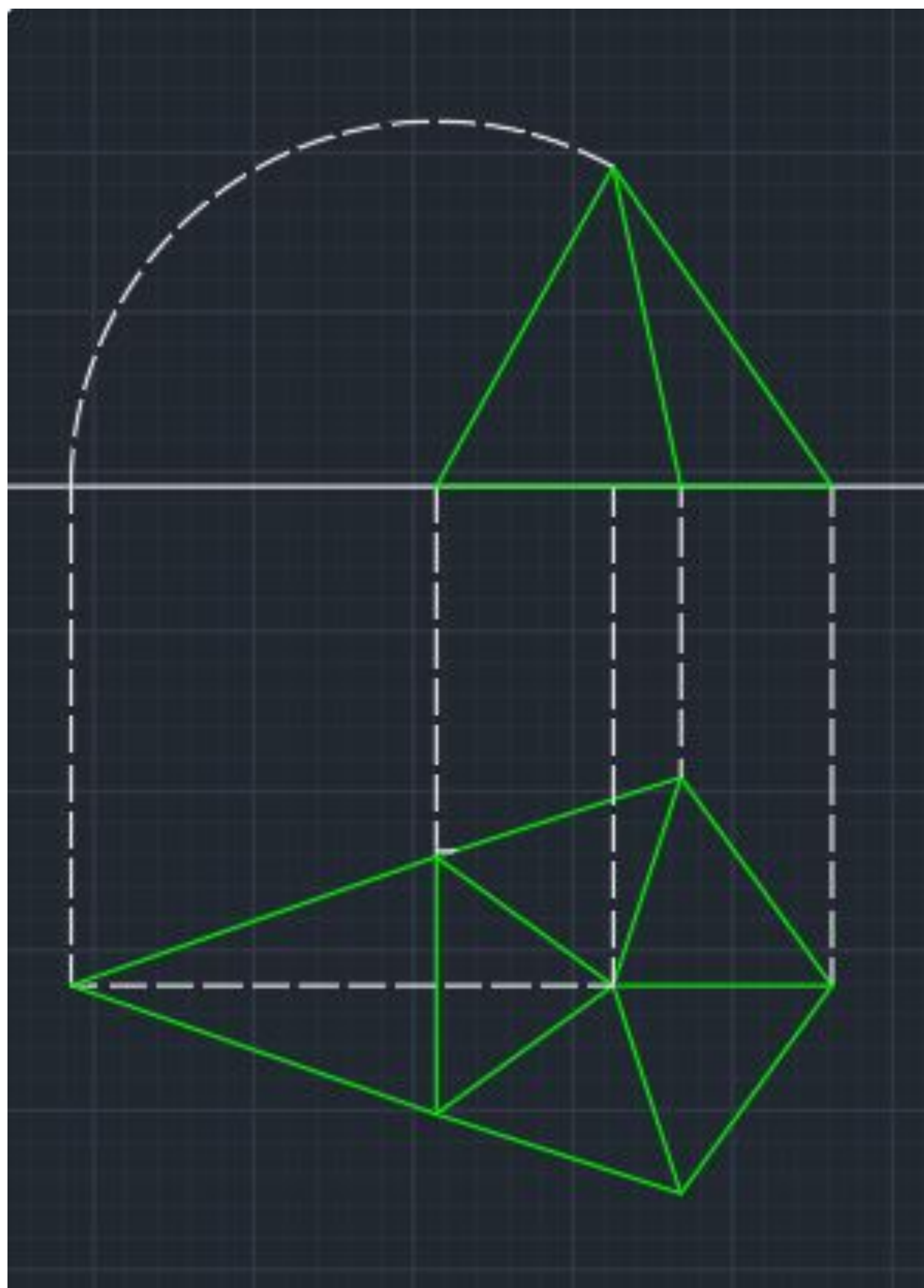

Exerc. 2.2 - pirâmide Pentagonal

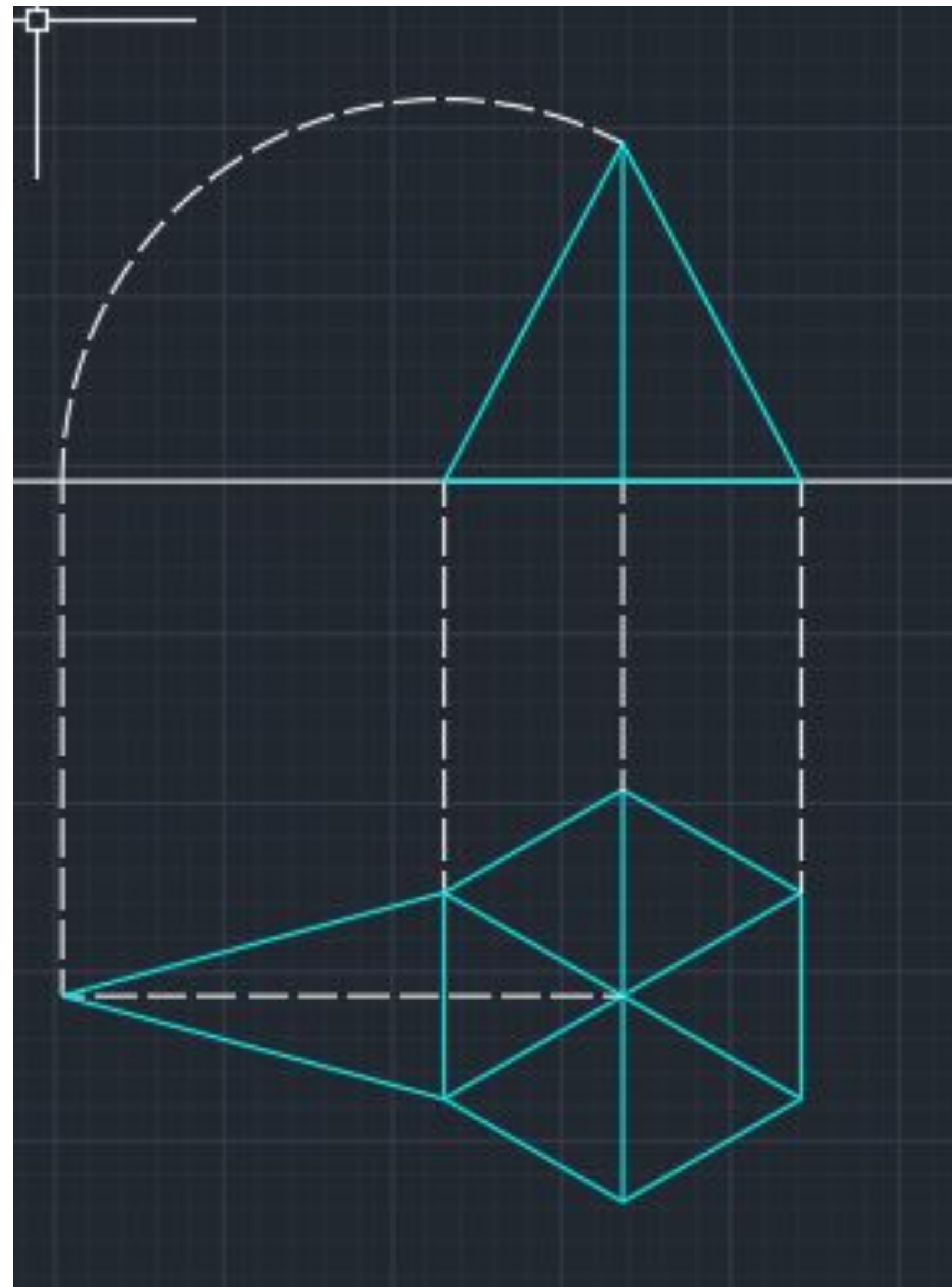

Exerc. 2.2 - pirâmide Hexagonal

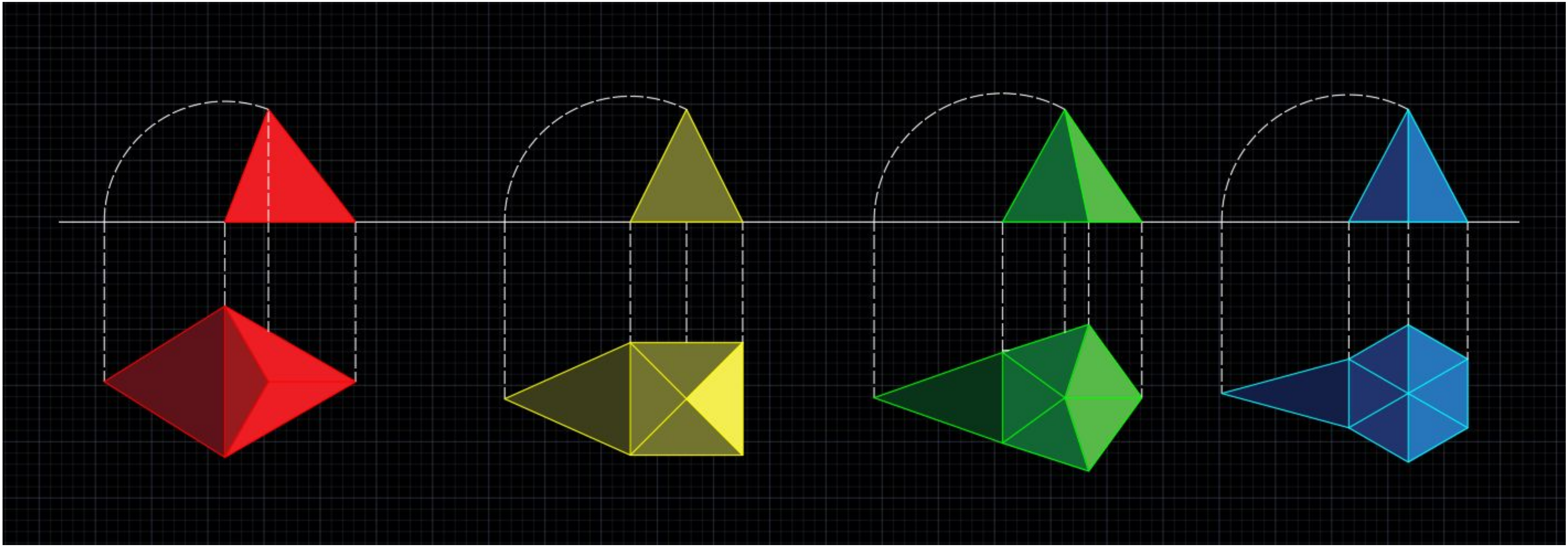

# Aula. 2.2 - Sombras

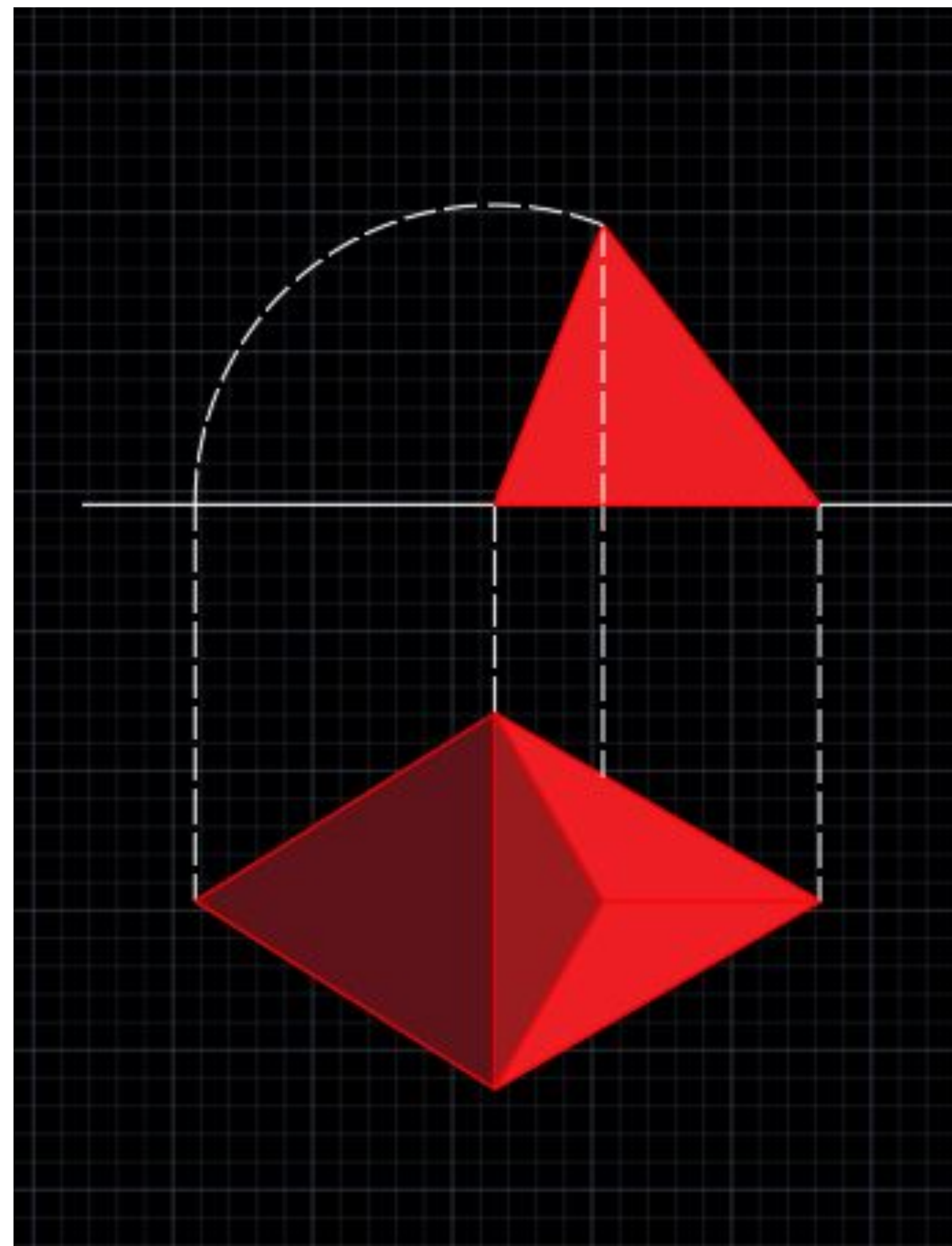

Exerc. 2.1.1 - pirâmide Triangular

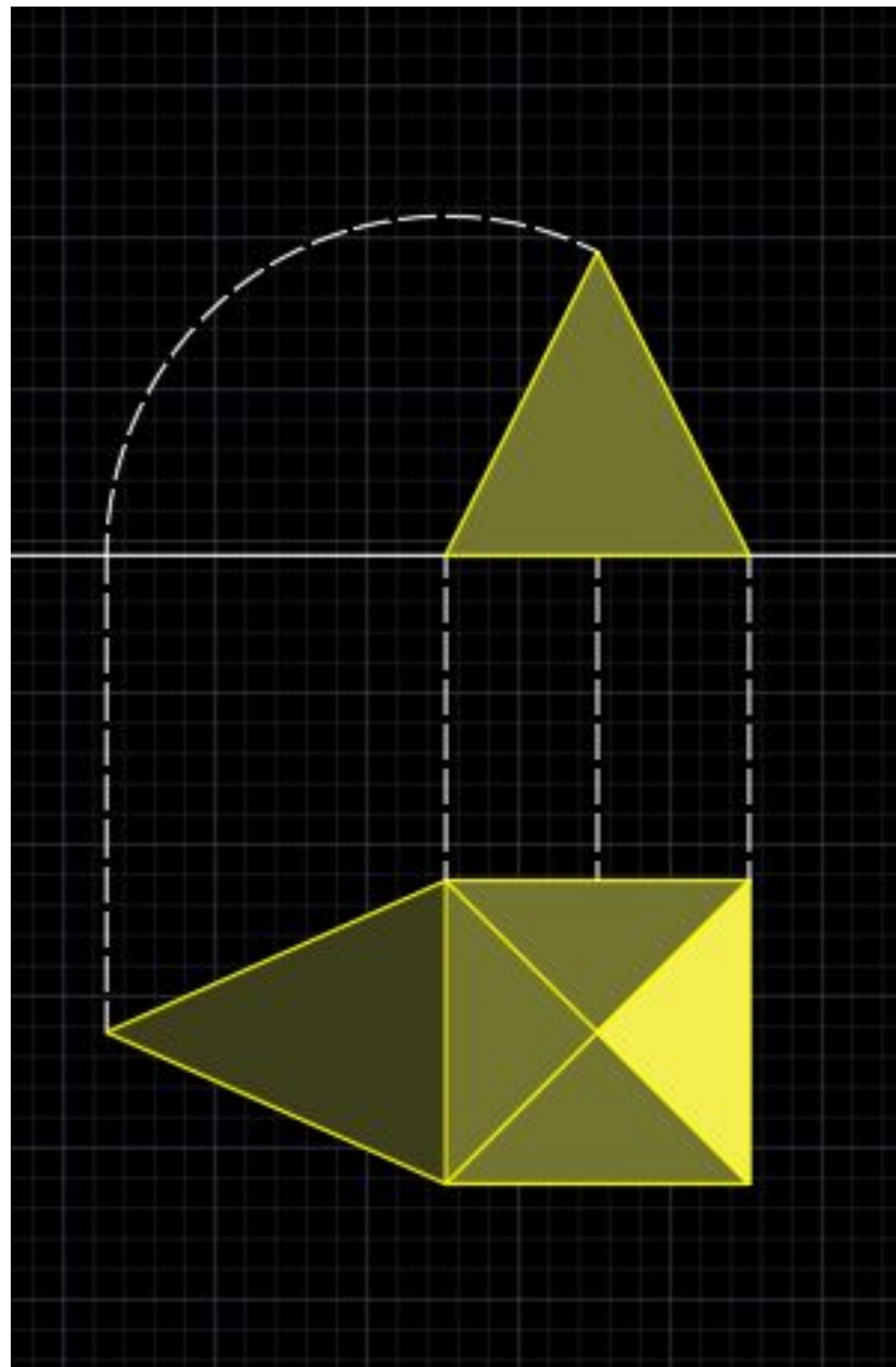

Exerc. 2.2.2 - pirâmide Quadrangular

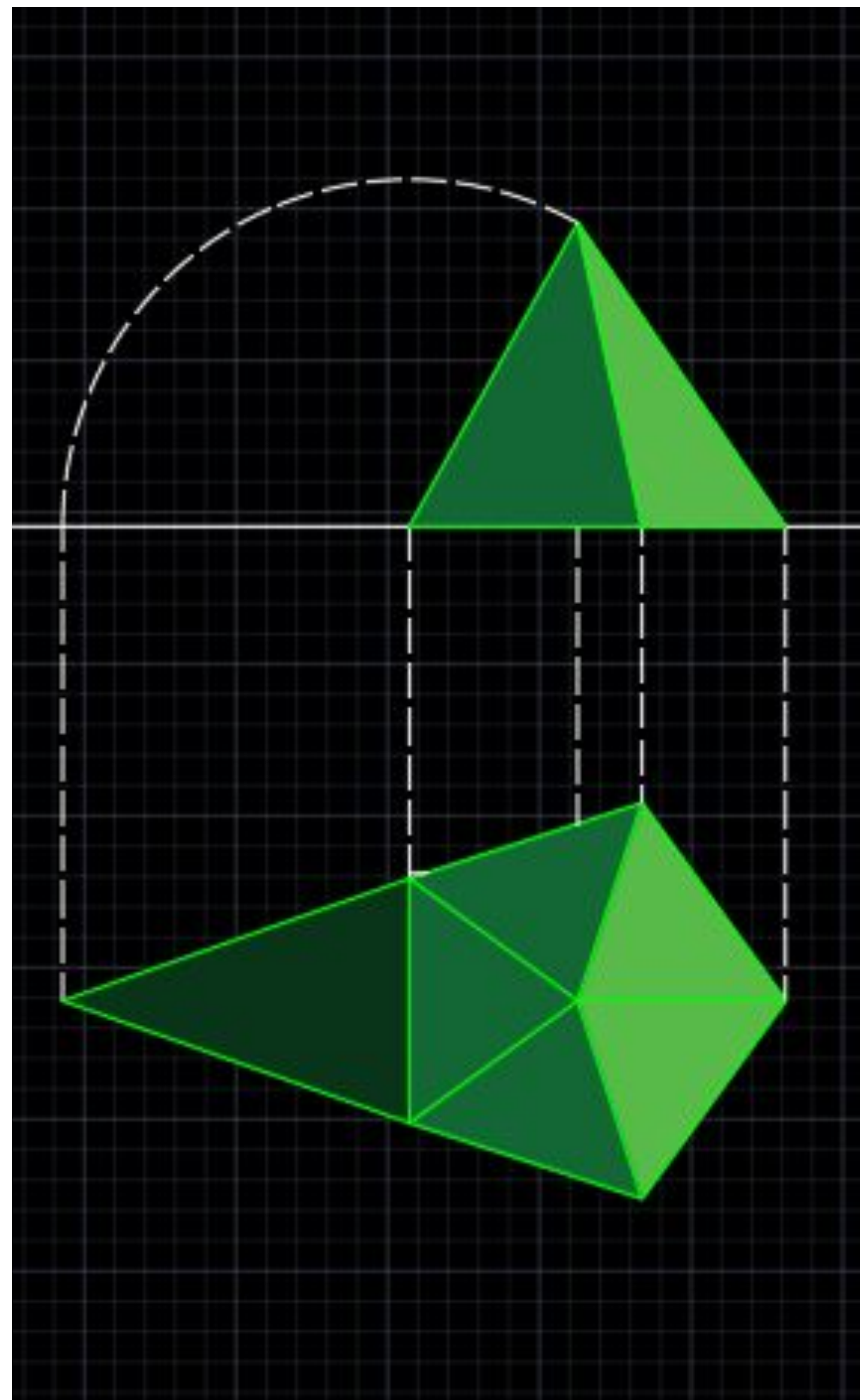

Exerc. 2.2.3 - pirâmide Pentagonal

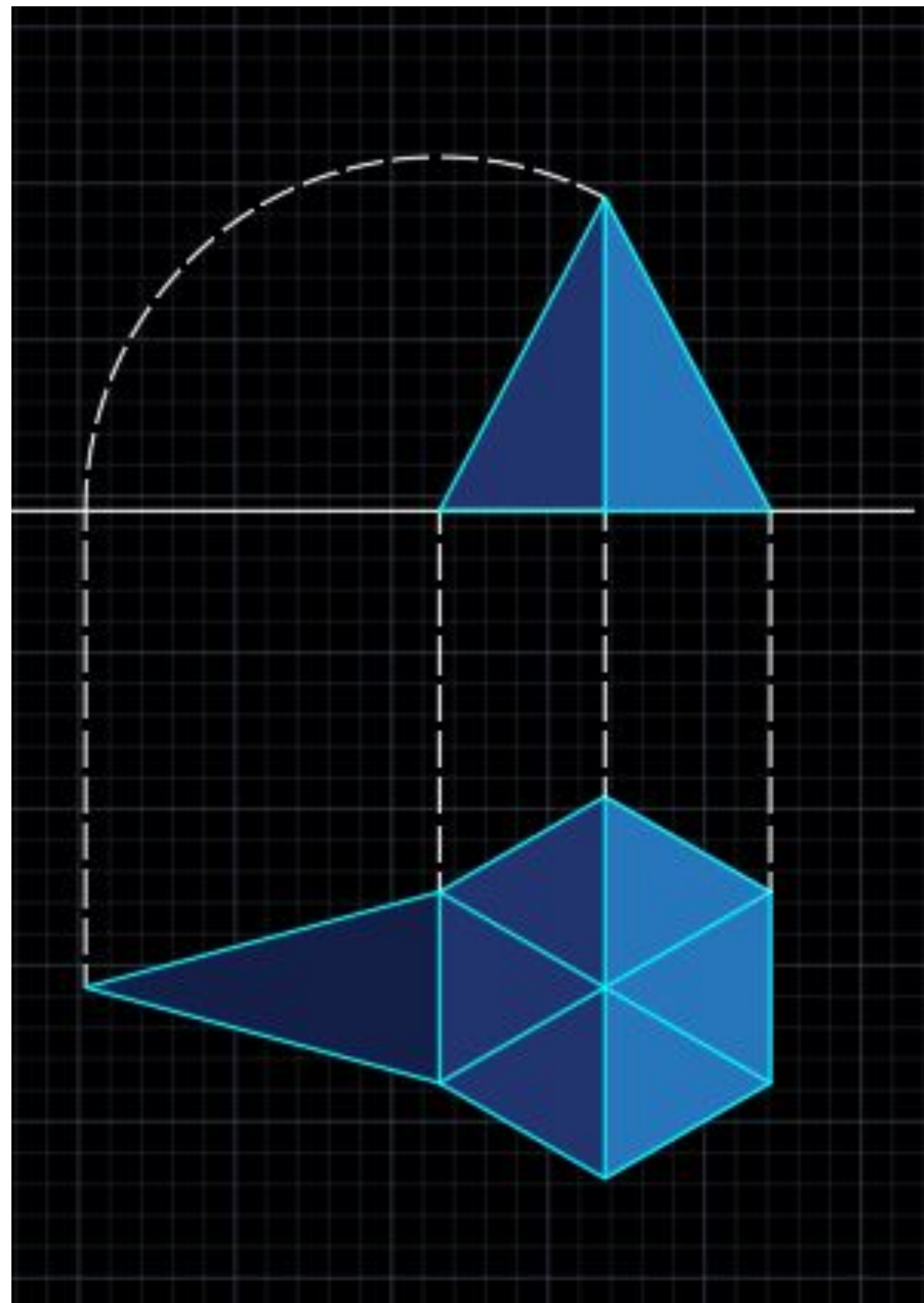

Exerc. 2.2.4 - pirâmide Hexagonal



Aula. 3.1 - Restauração de uma planta



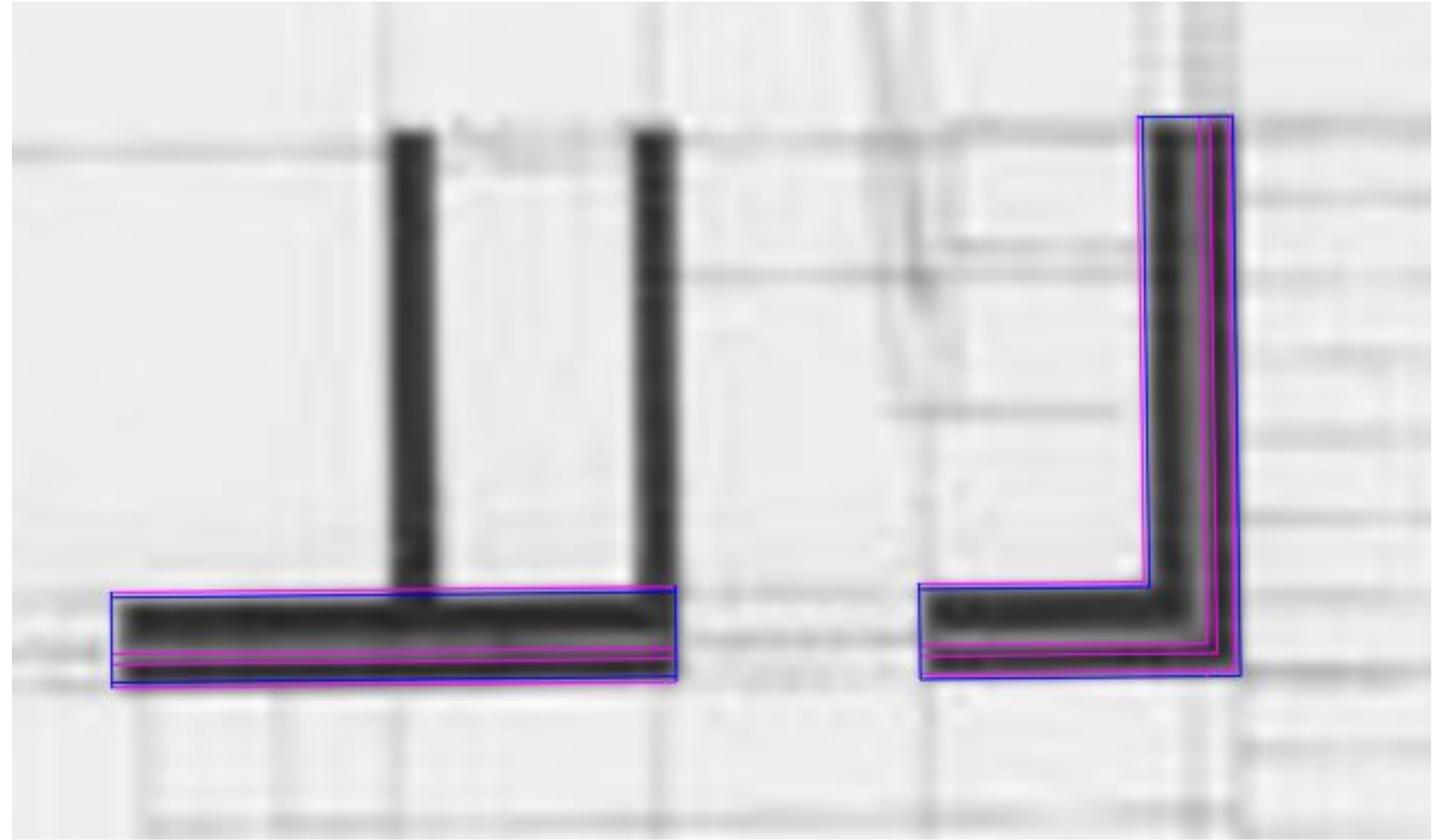
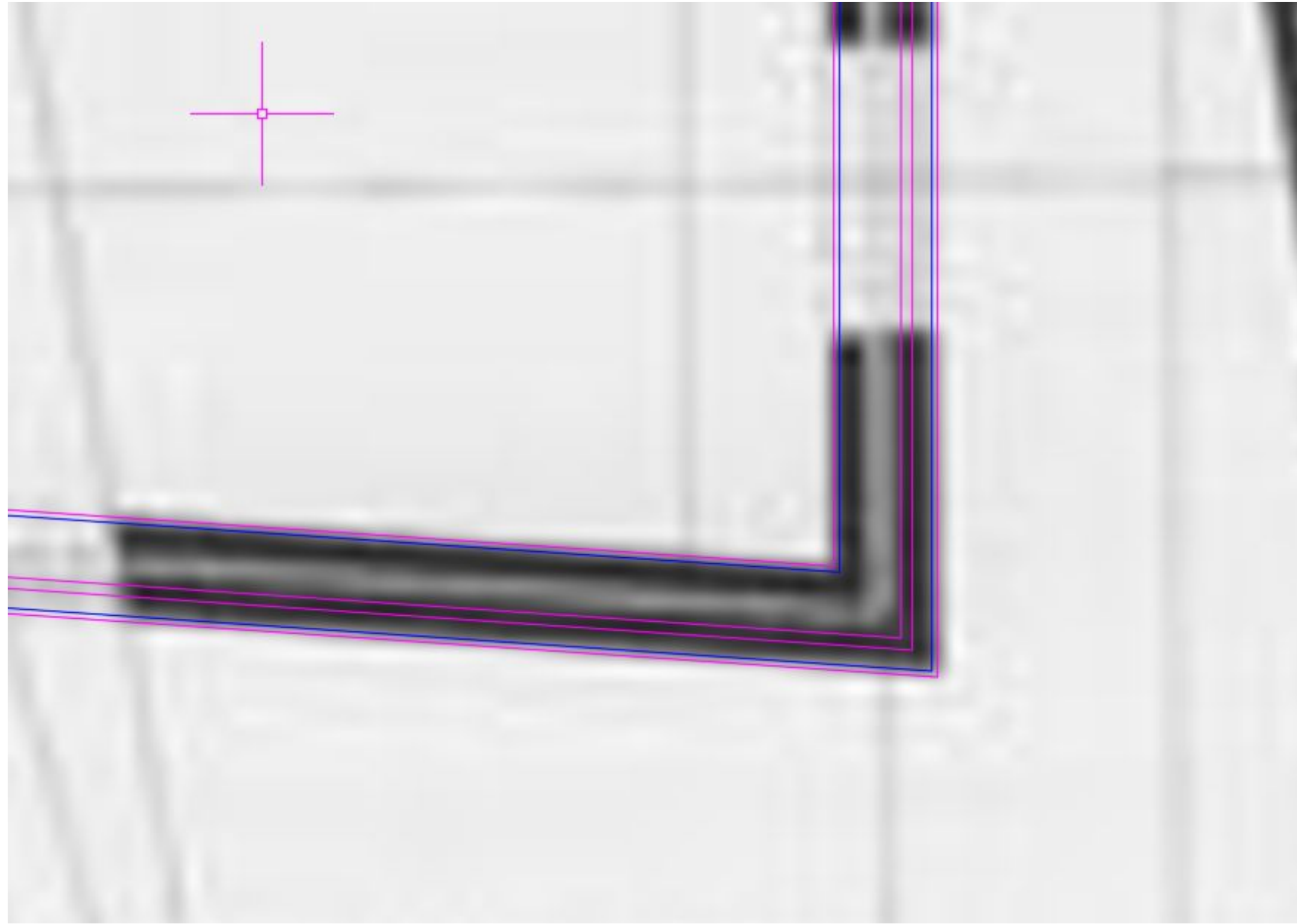

Exerc. 3.1 - Execução de paredes

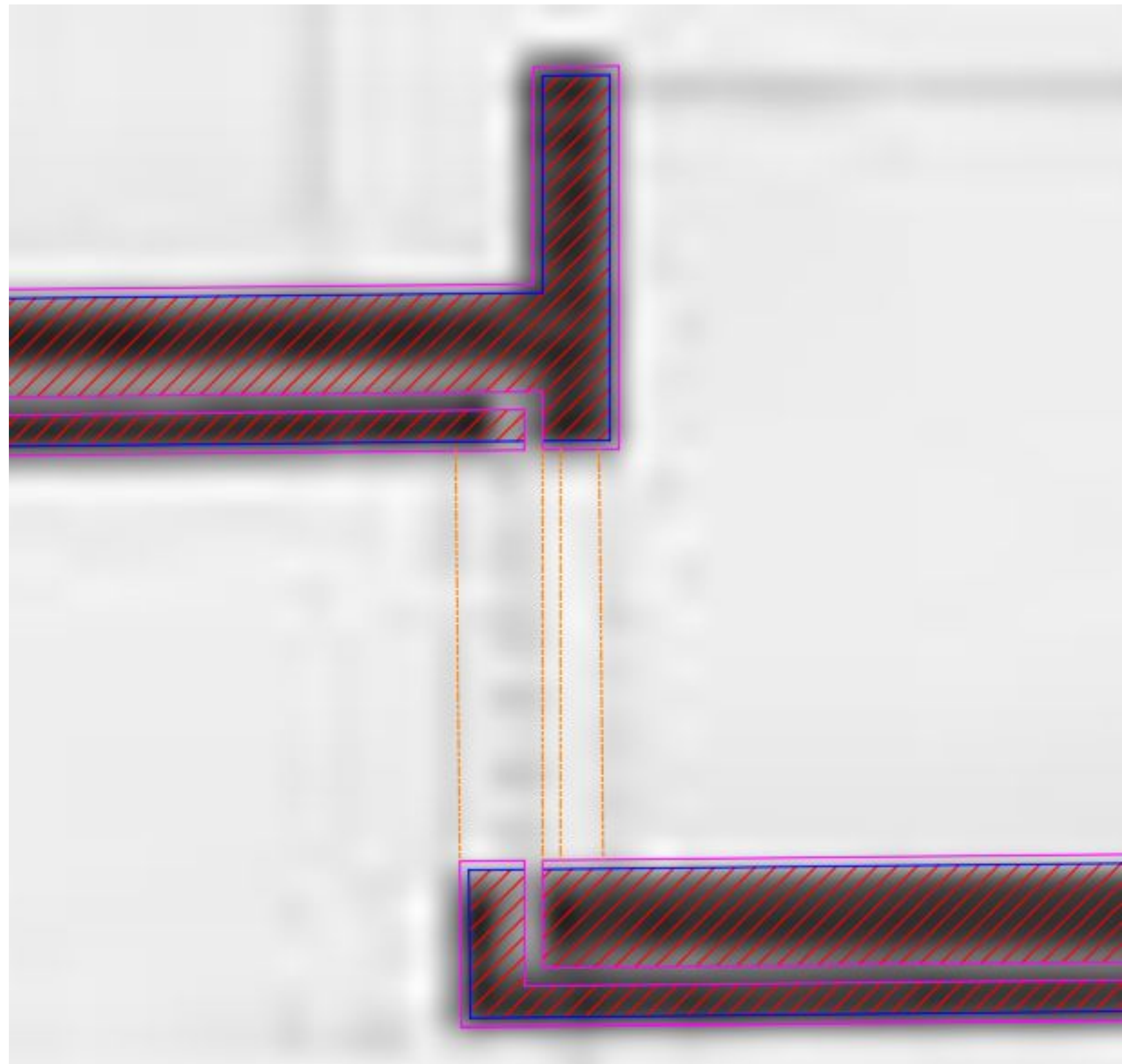
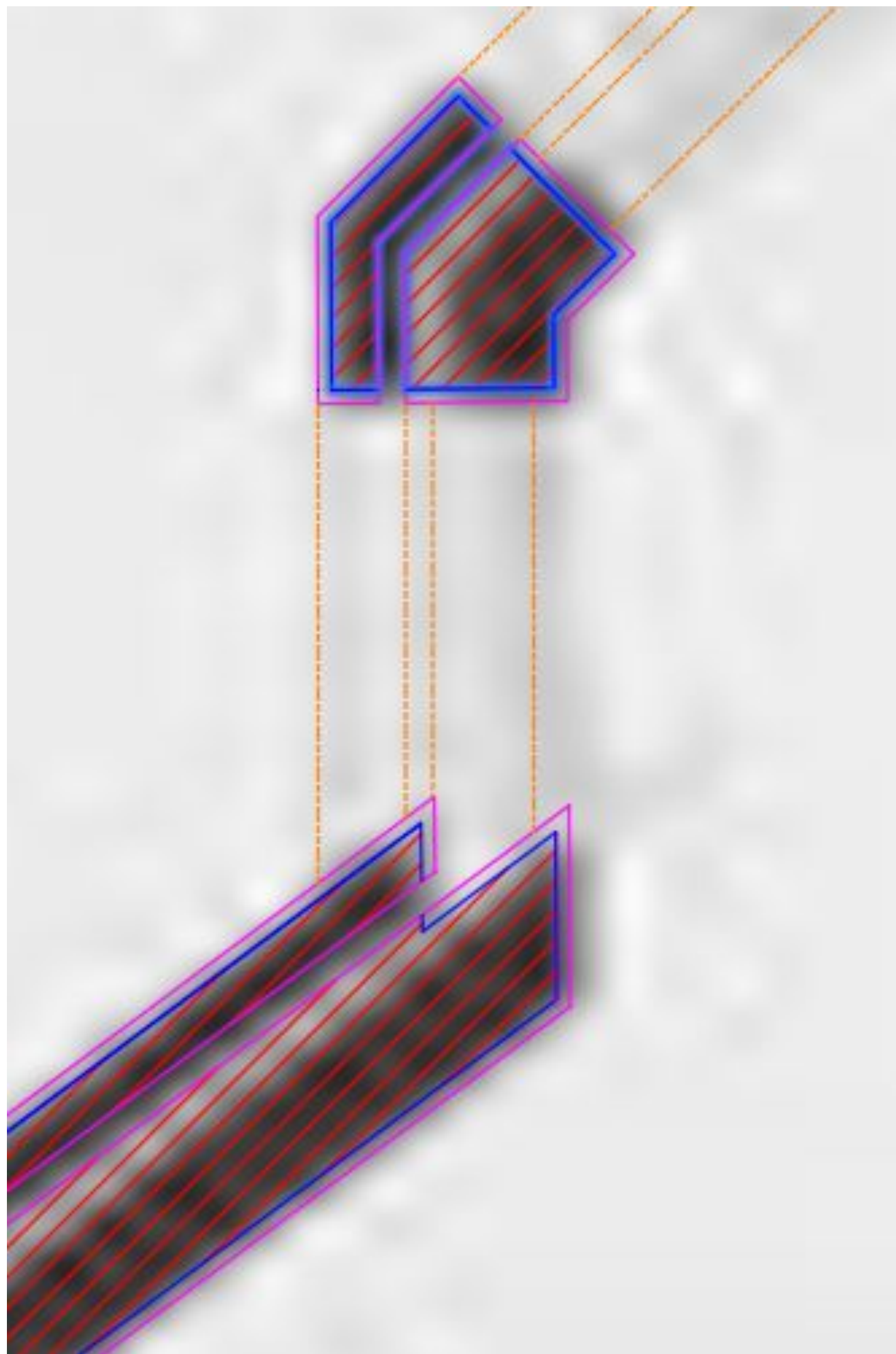

Exerc. 3.3 - Malha

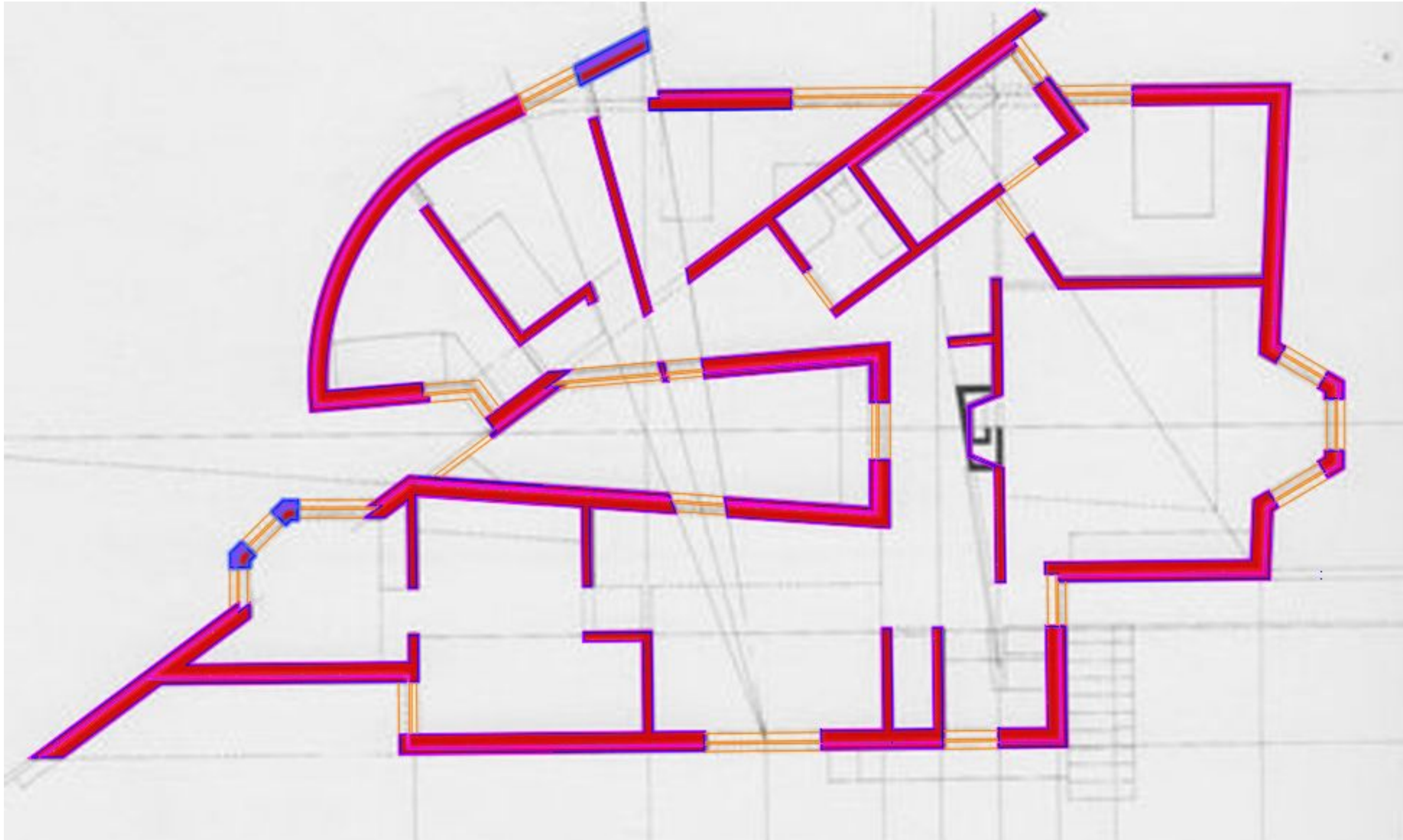

Exerc. 3.2 - Execução Planta 1

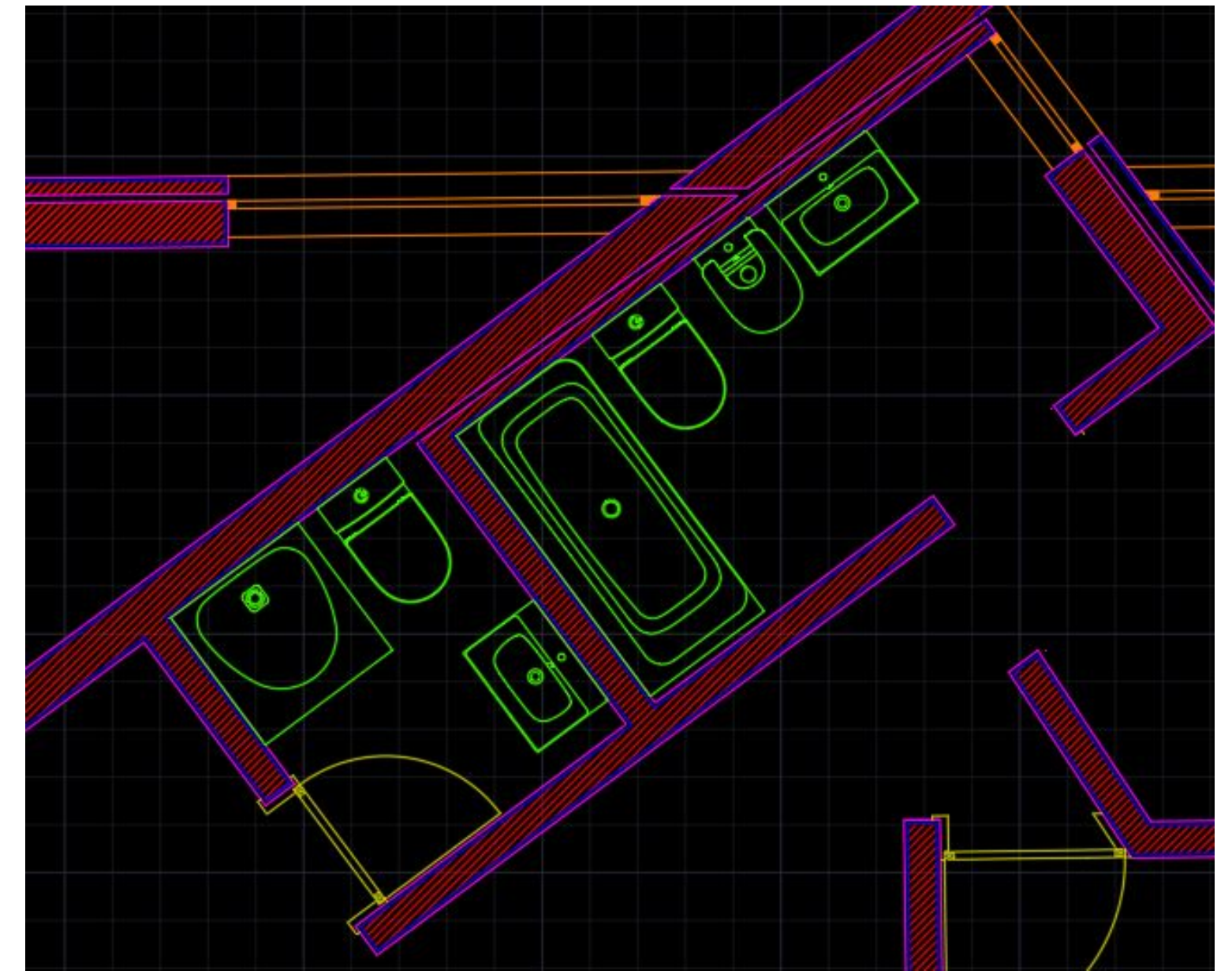
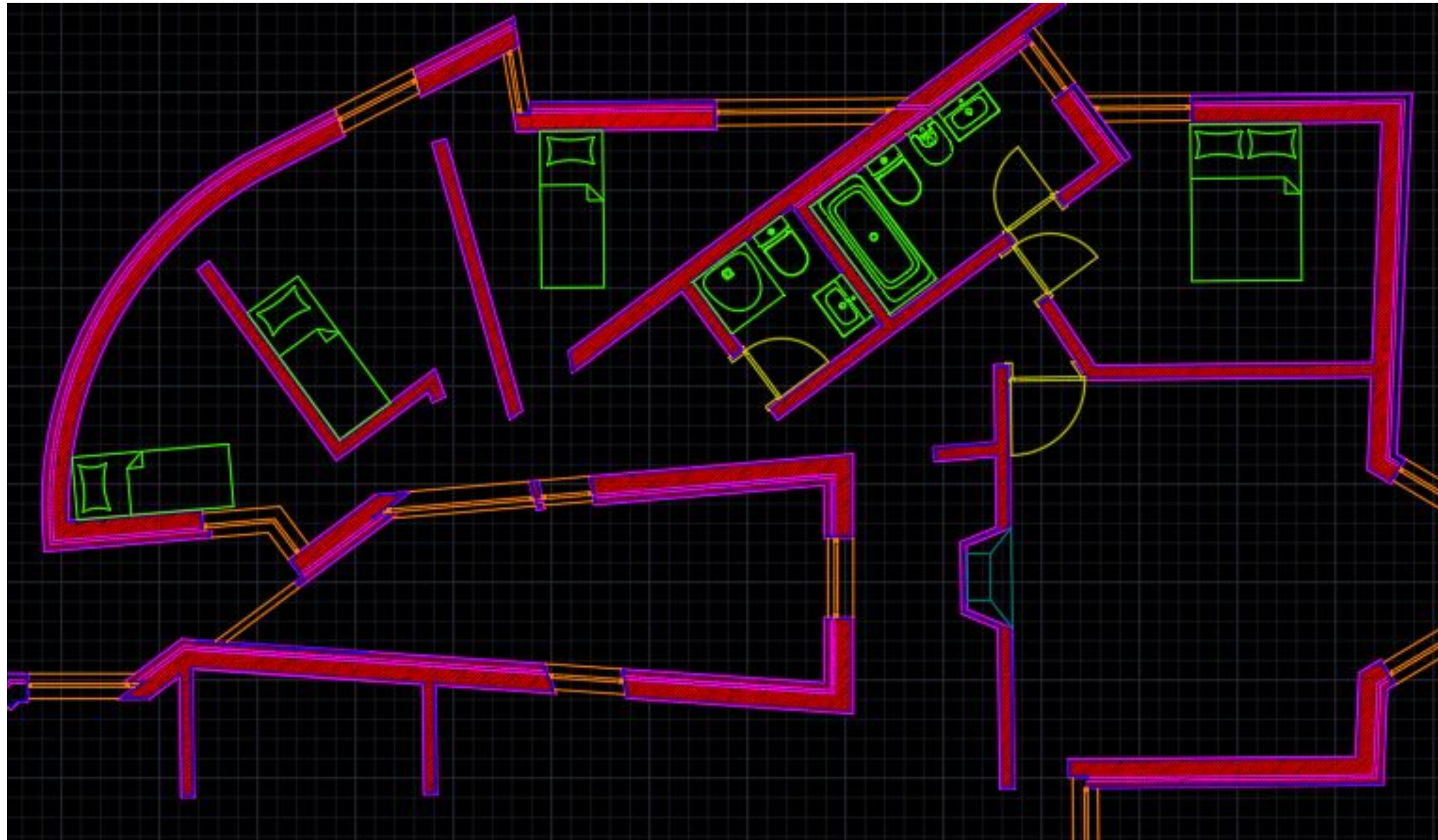

Exerc. 3.3 - Camas / Loiças

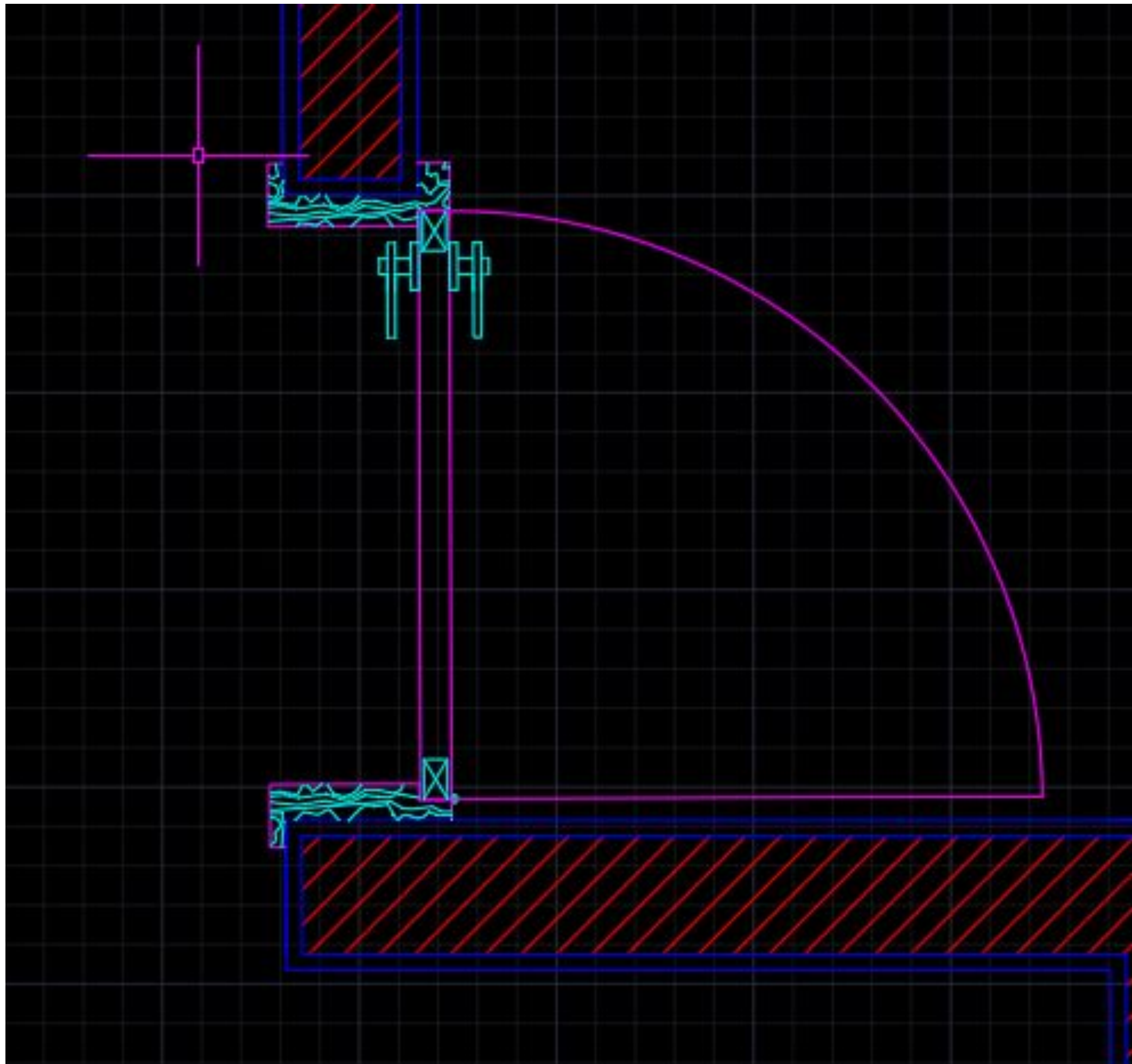

Exerc. 3.4 - Pormenores

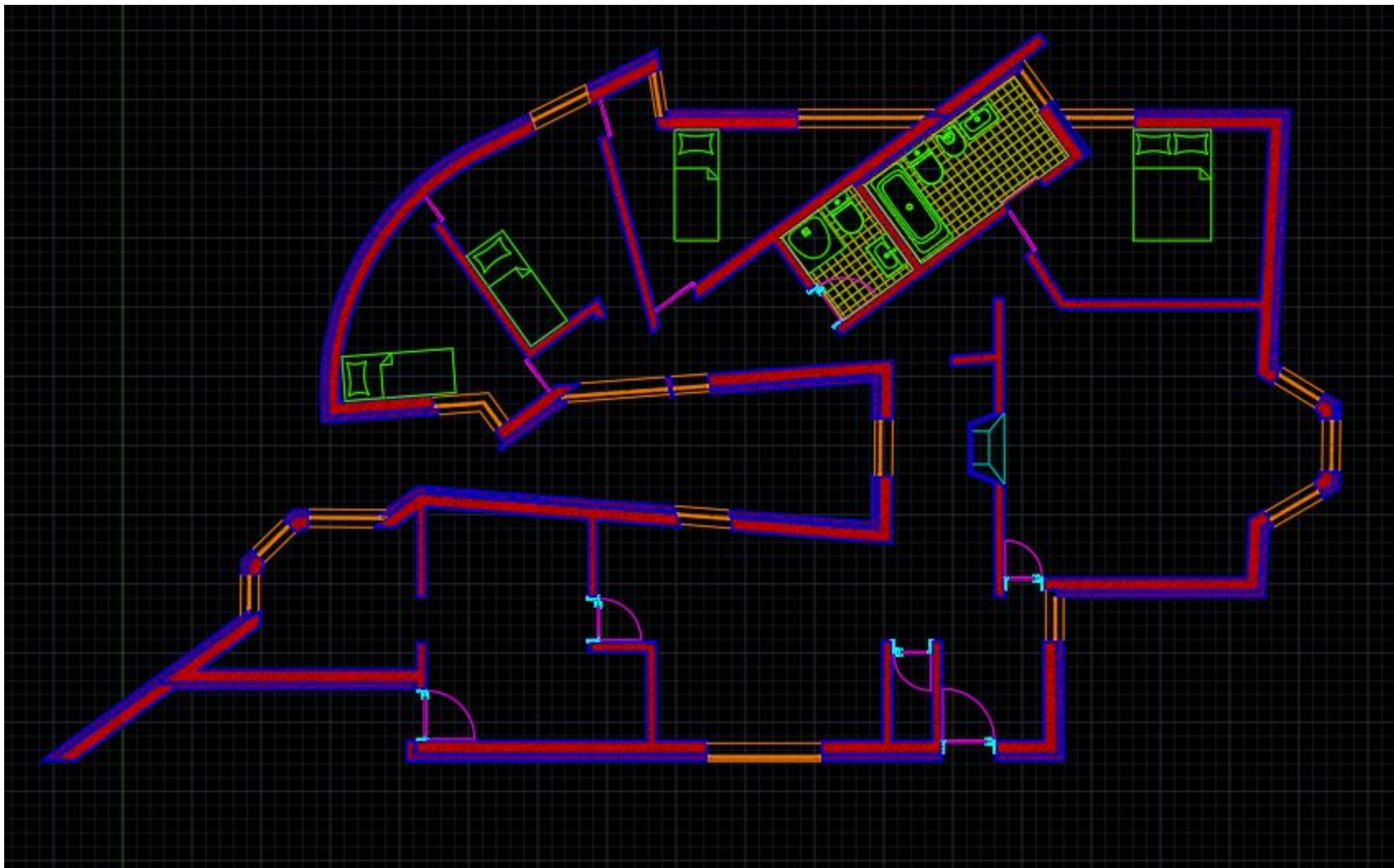

Exerc. 3.5 - Finalização de Planta

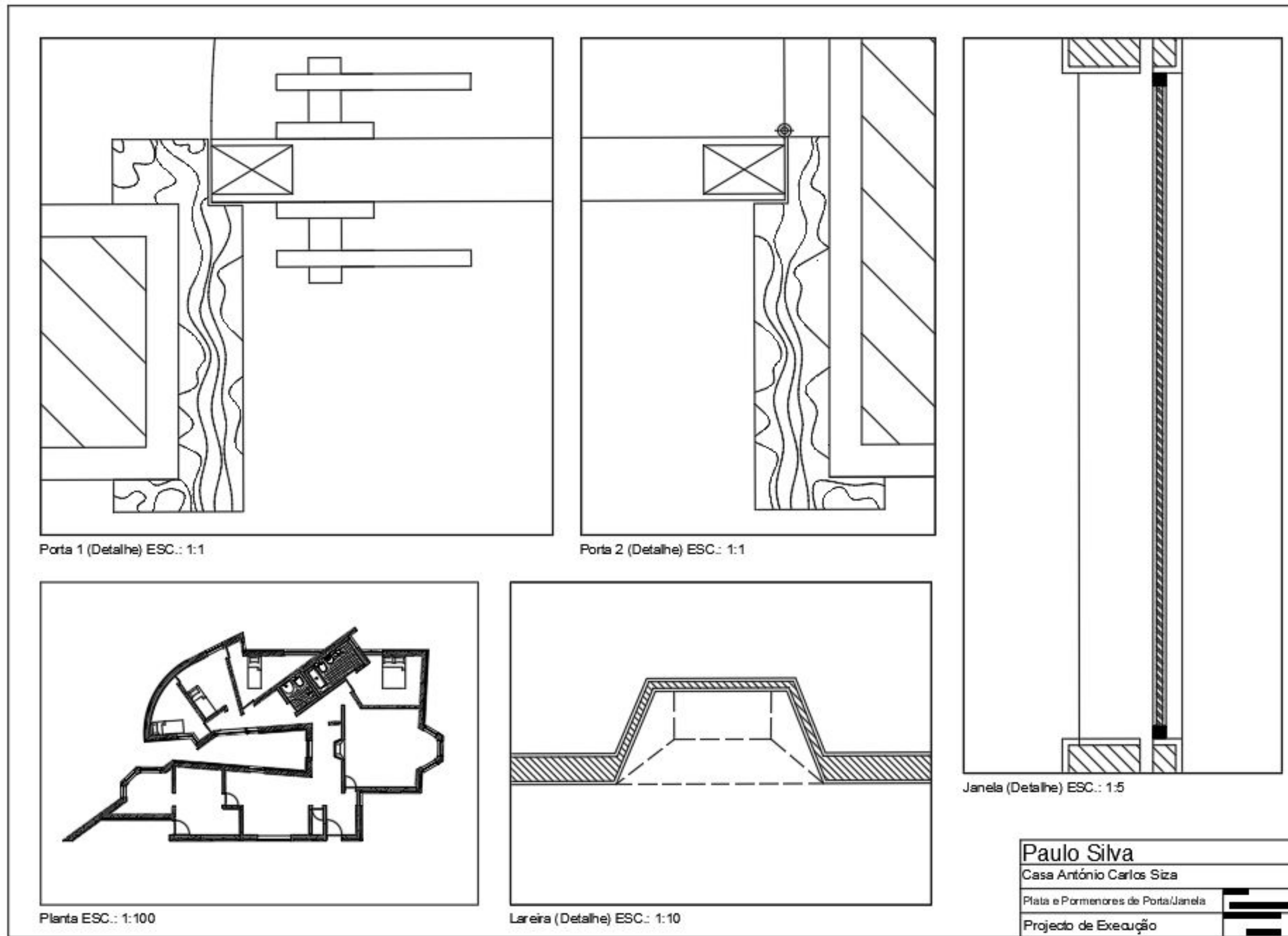

# Exerc. 3.6 - Preview

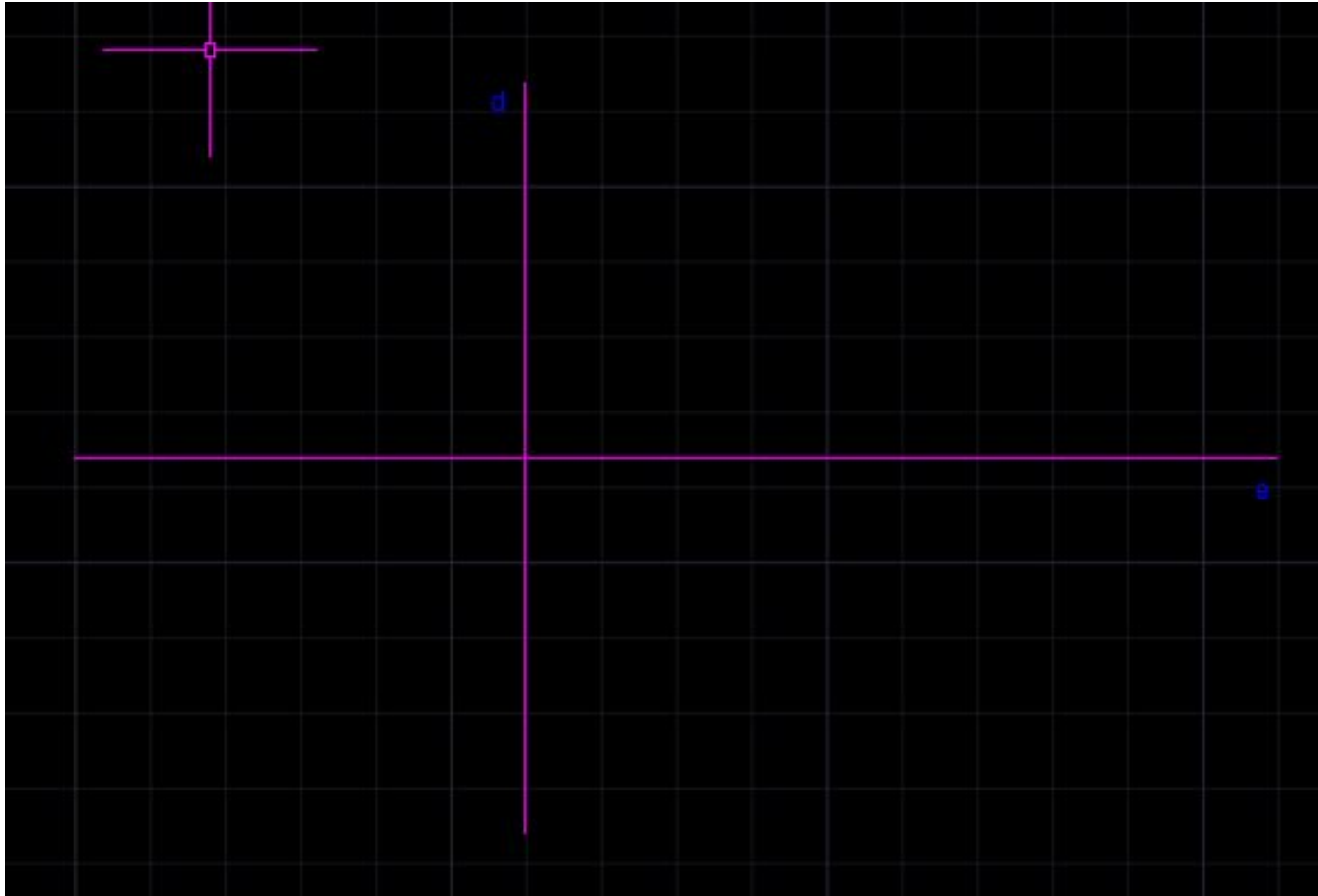

Exerc. 4.0 - Eixos



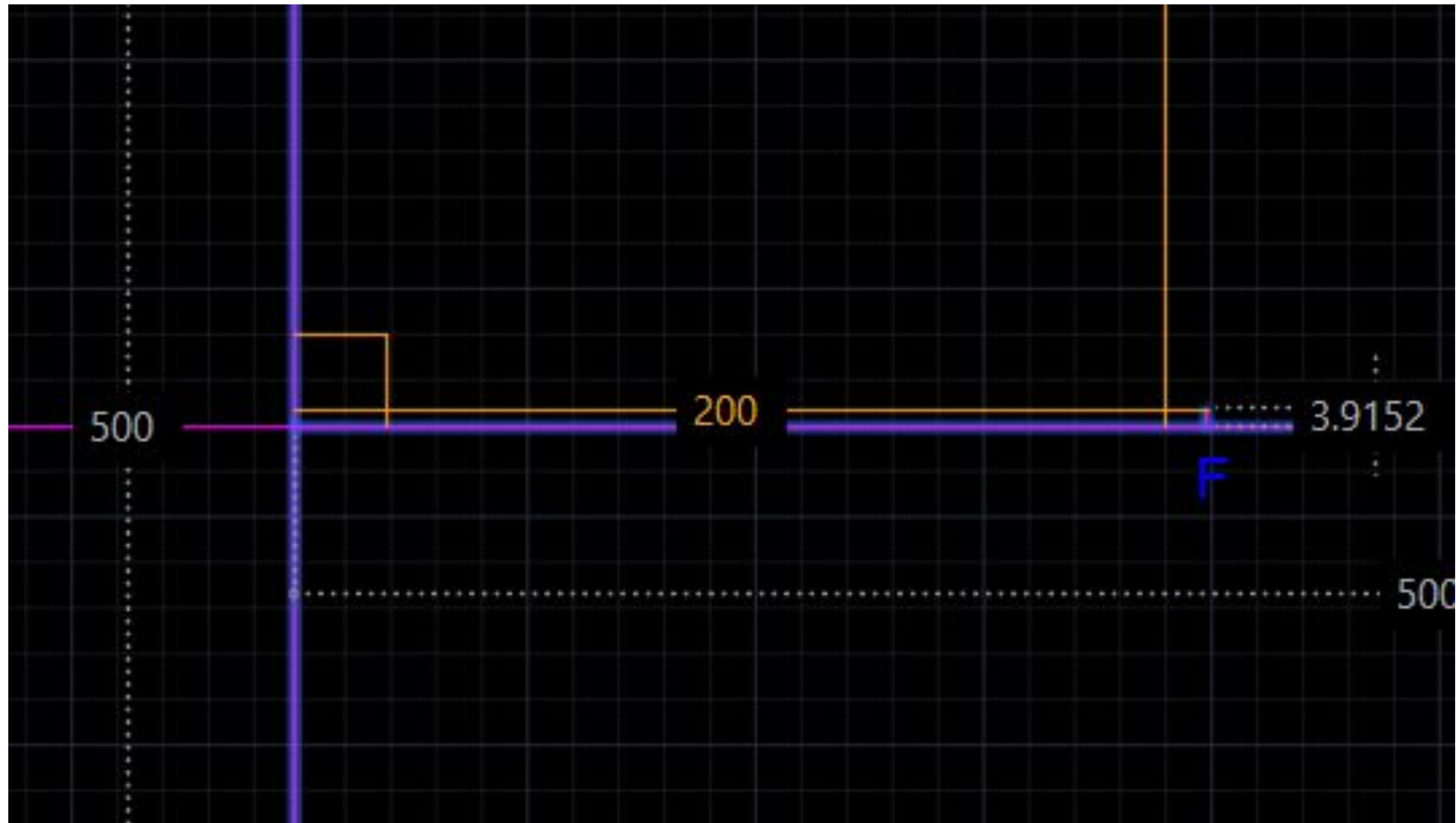

Exerc. 4.1 - Ponto F

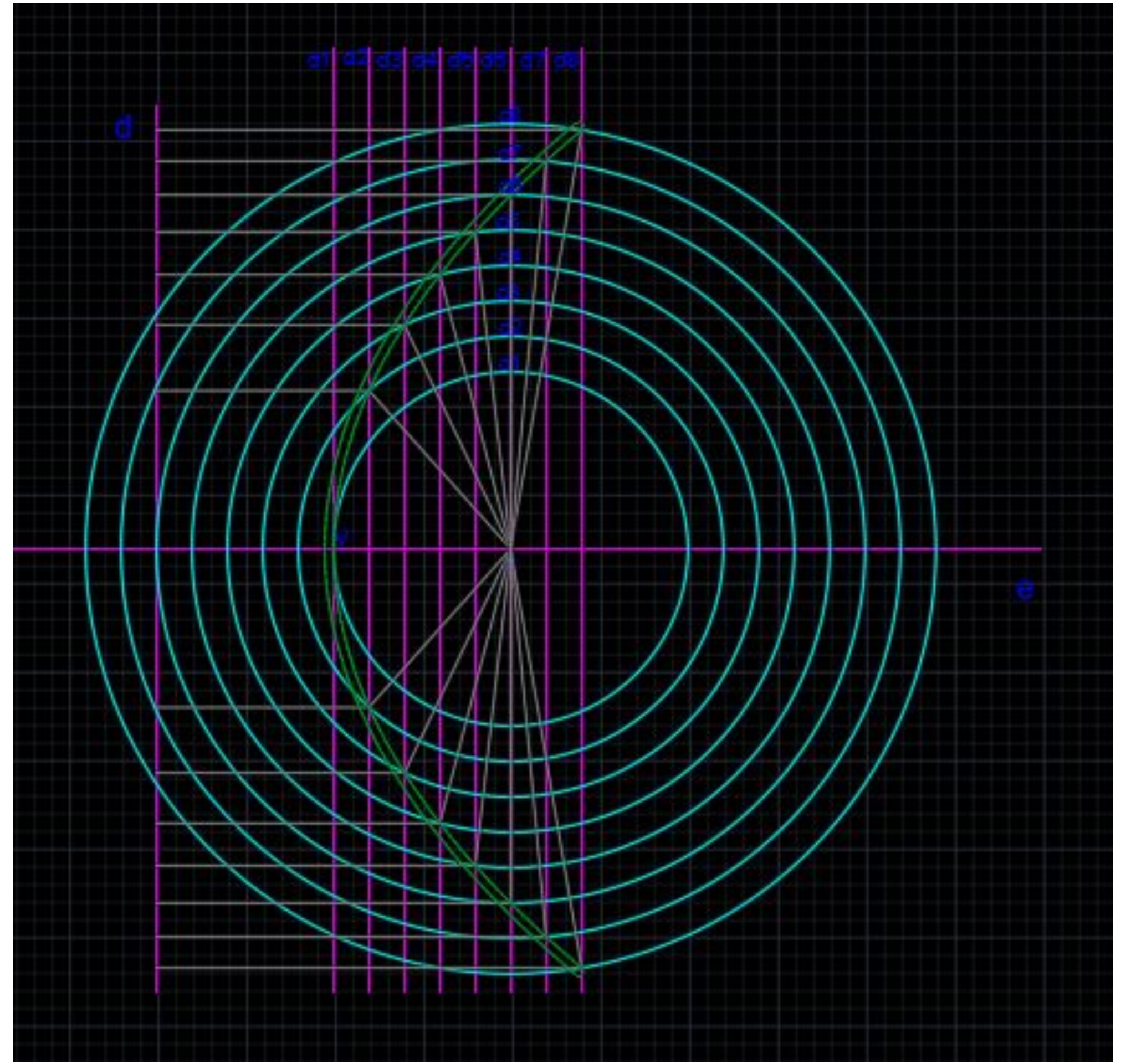
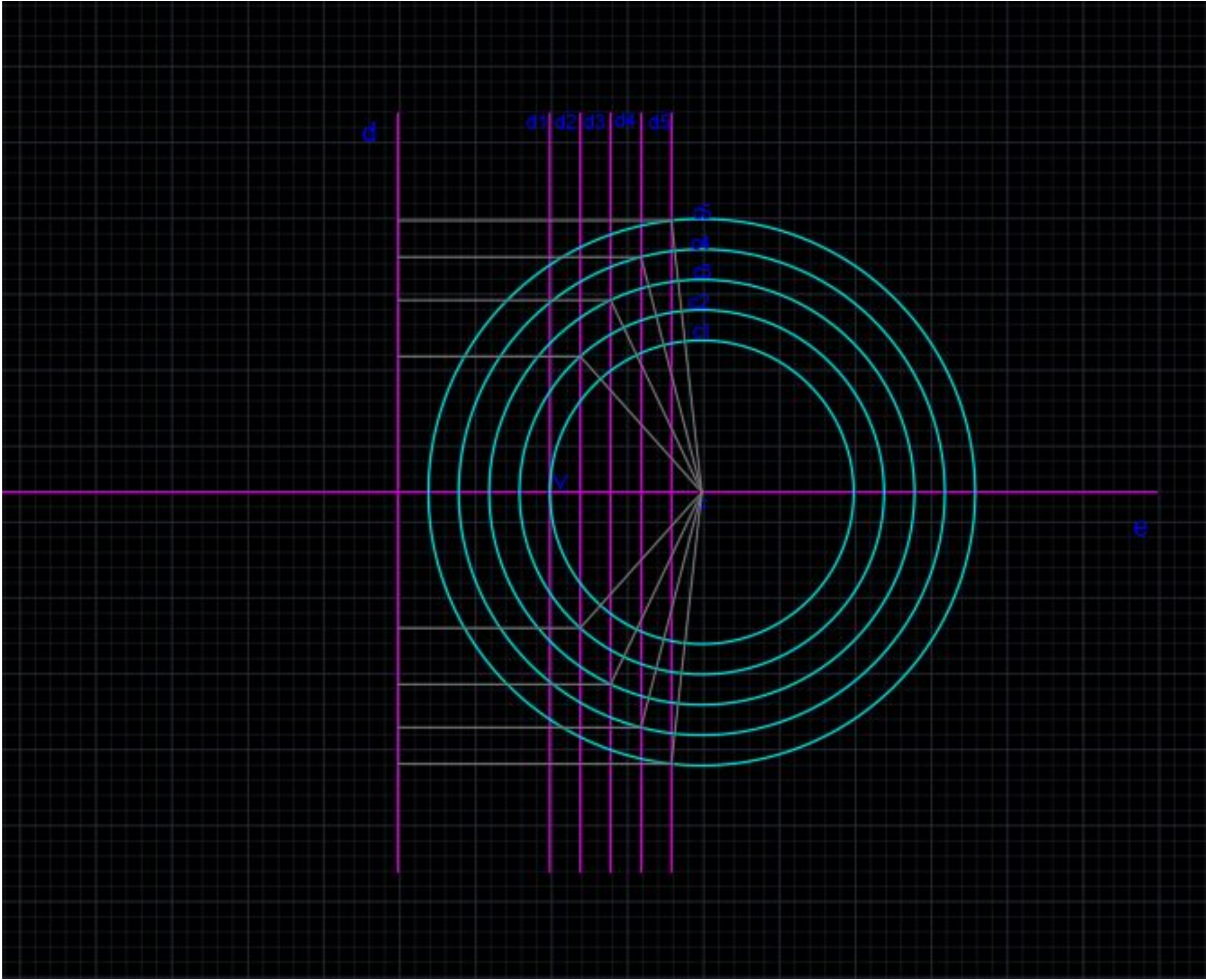

# Exerc. 4.3 - Parábola

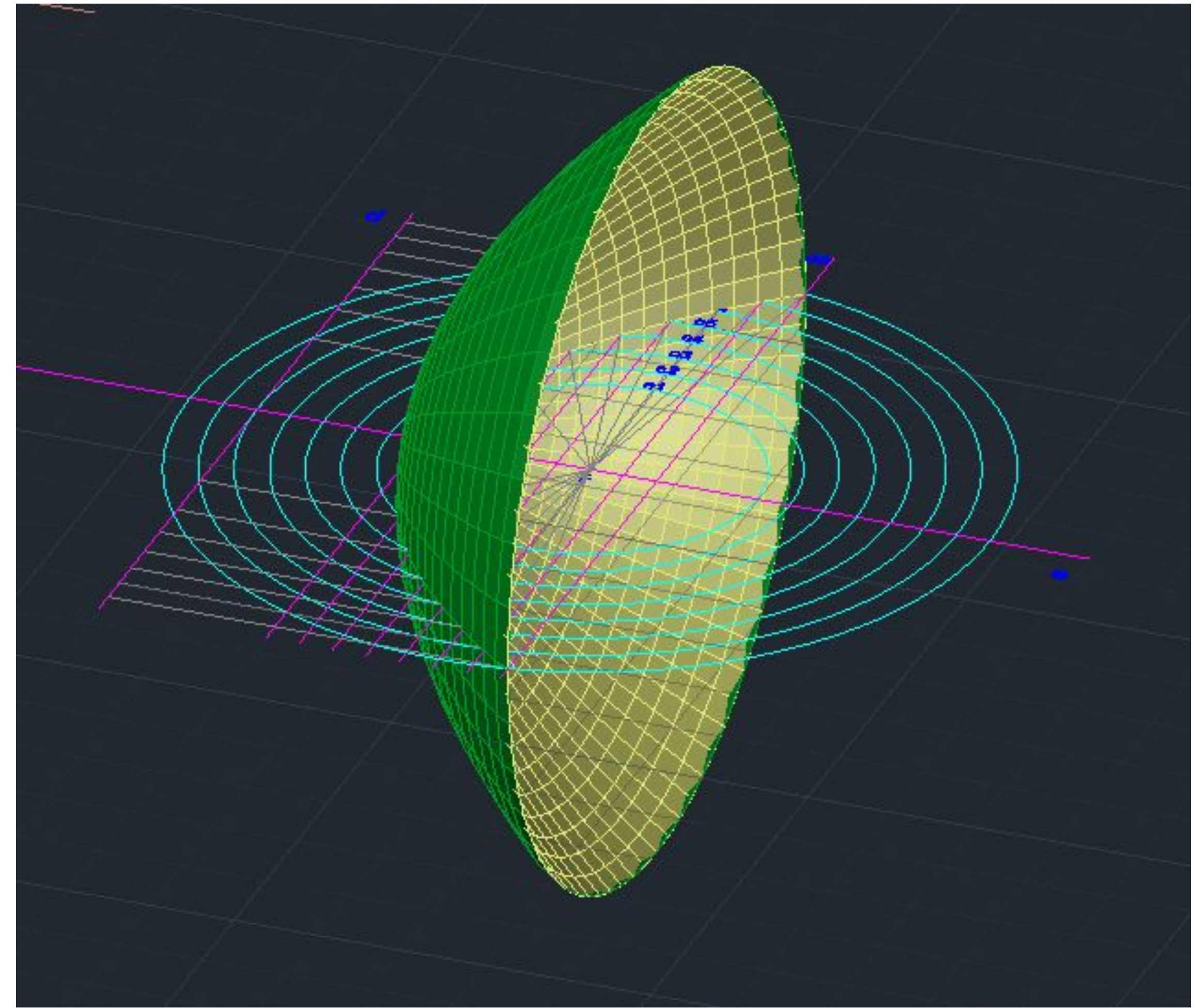
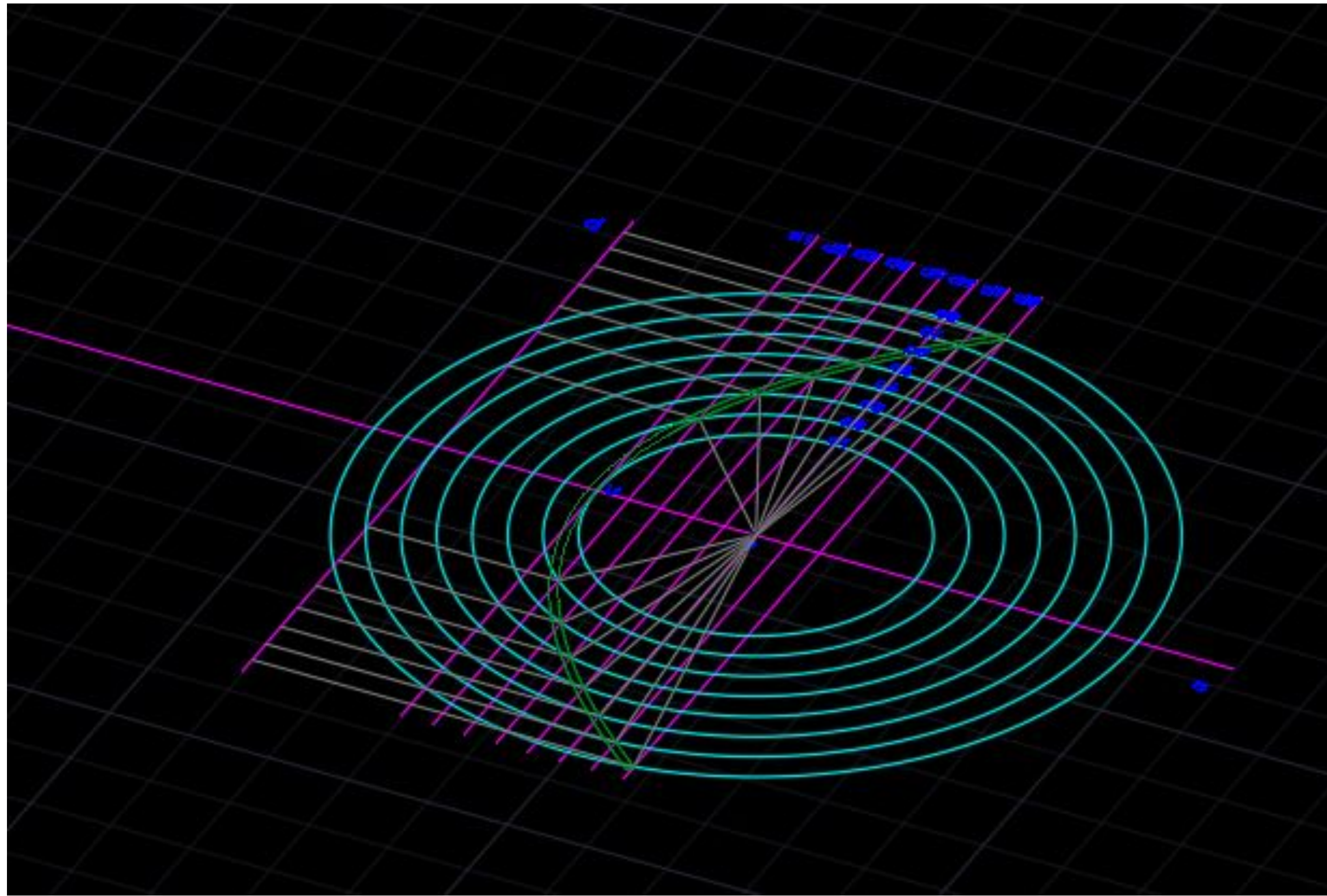

Exerc. 4.4 - Parabólica

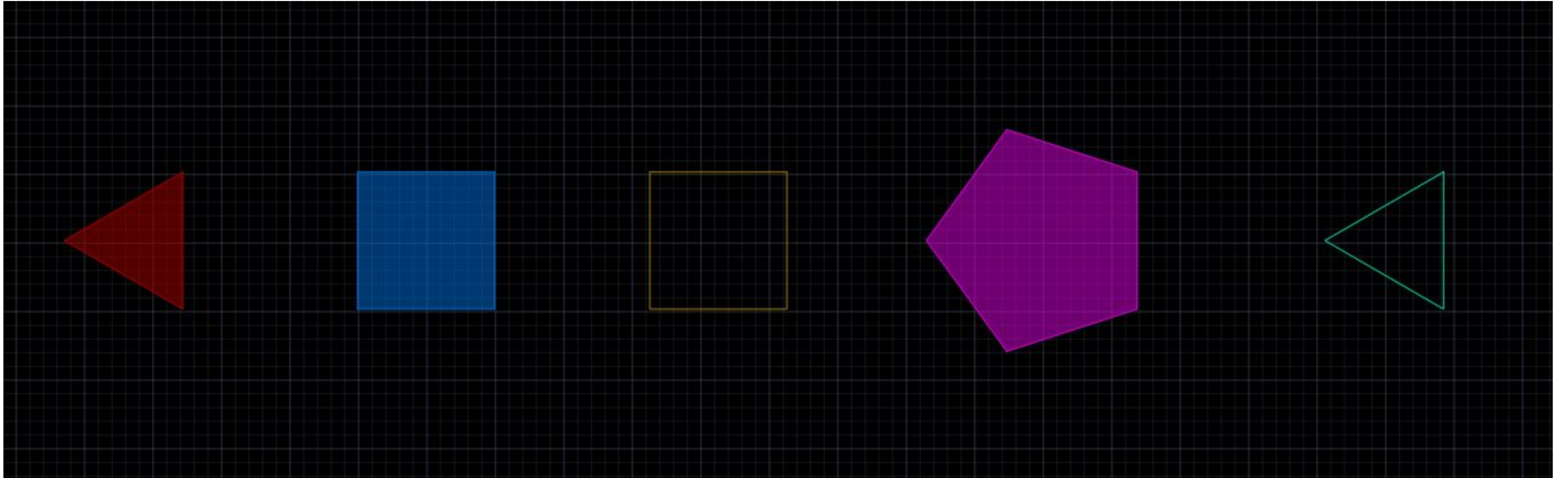

Exerc. 5.0 - Poligonos

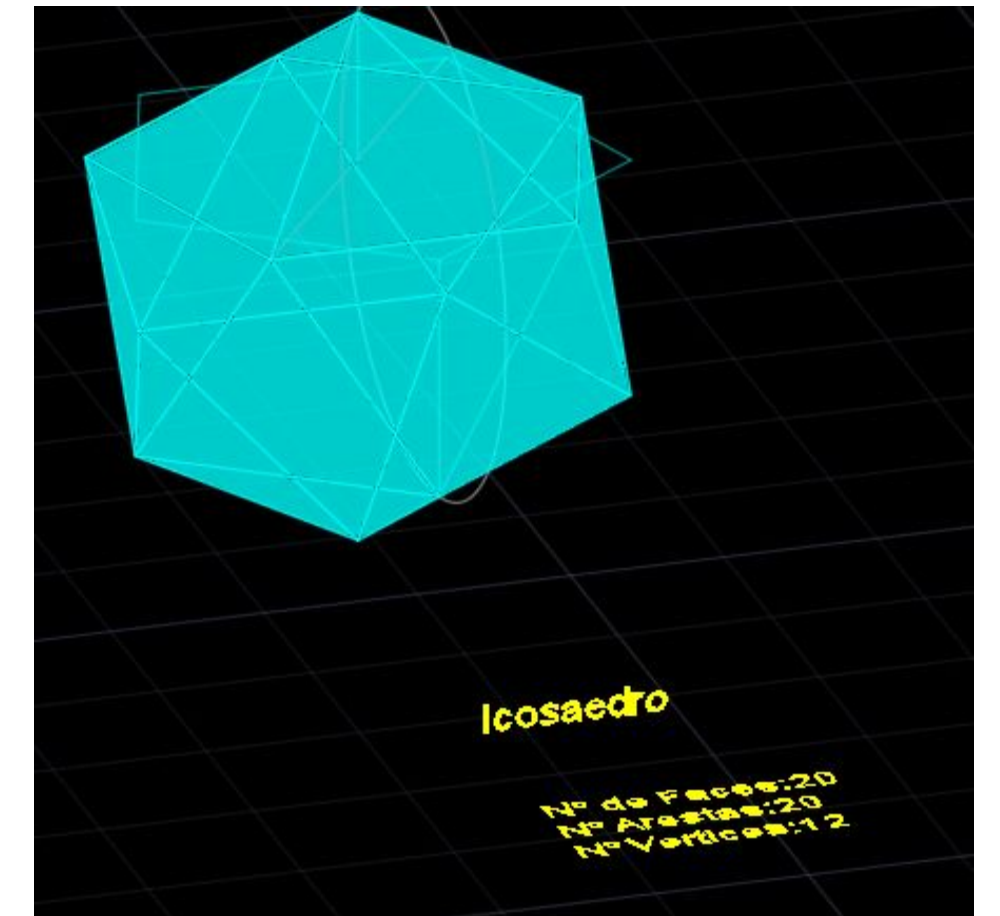
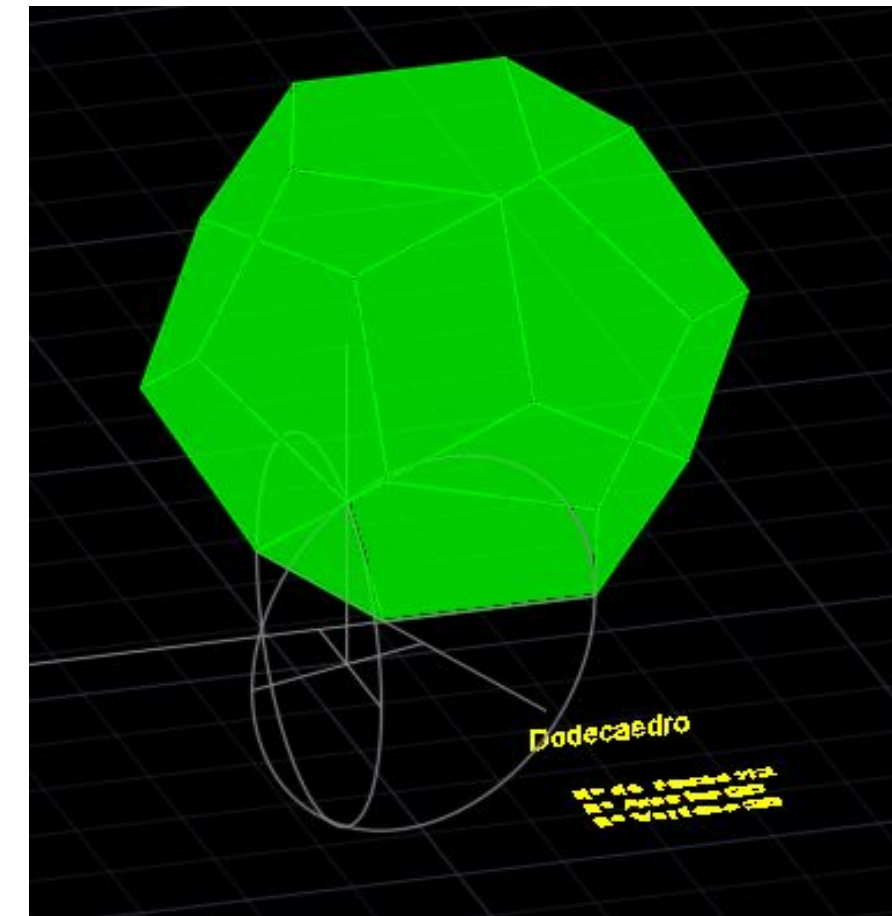
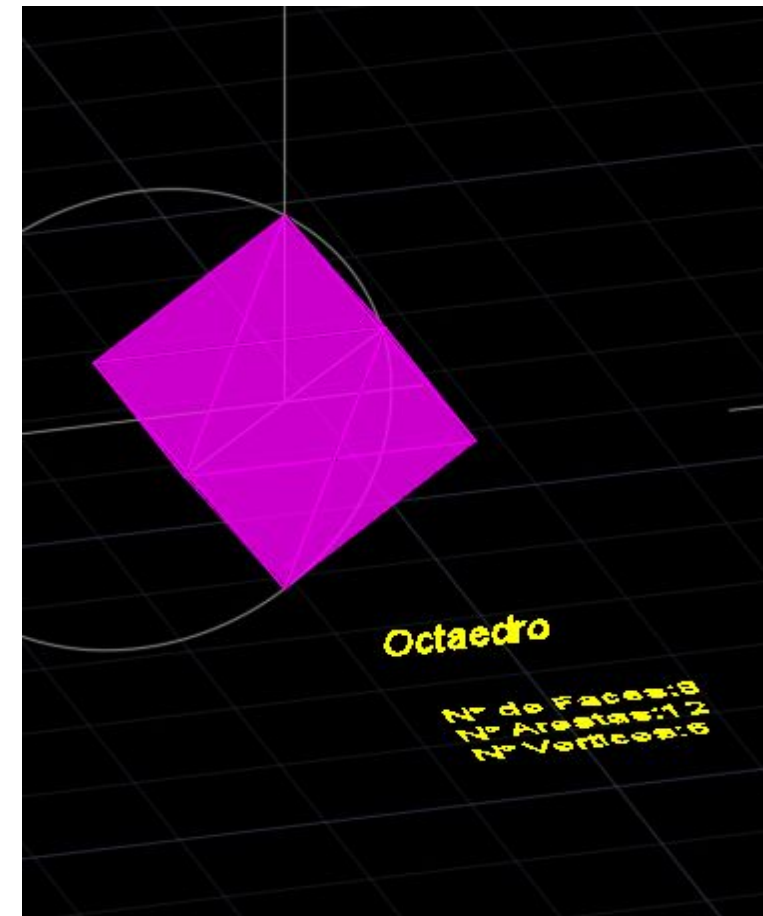
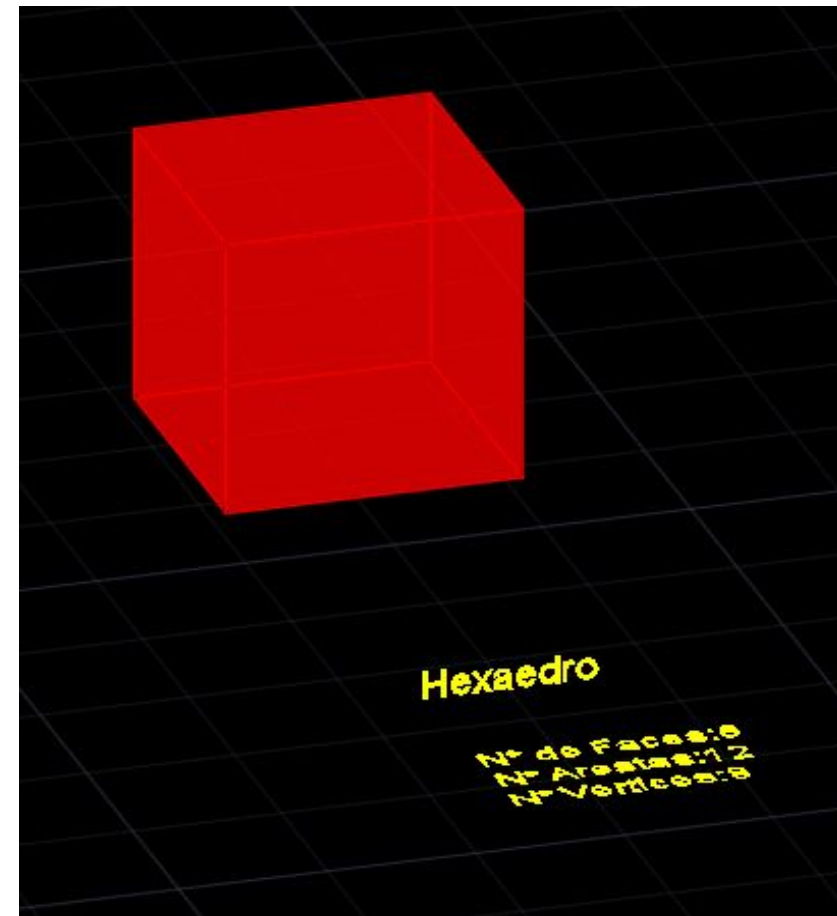
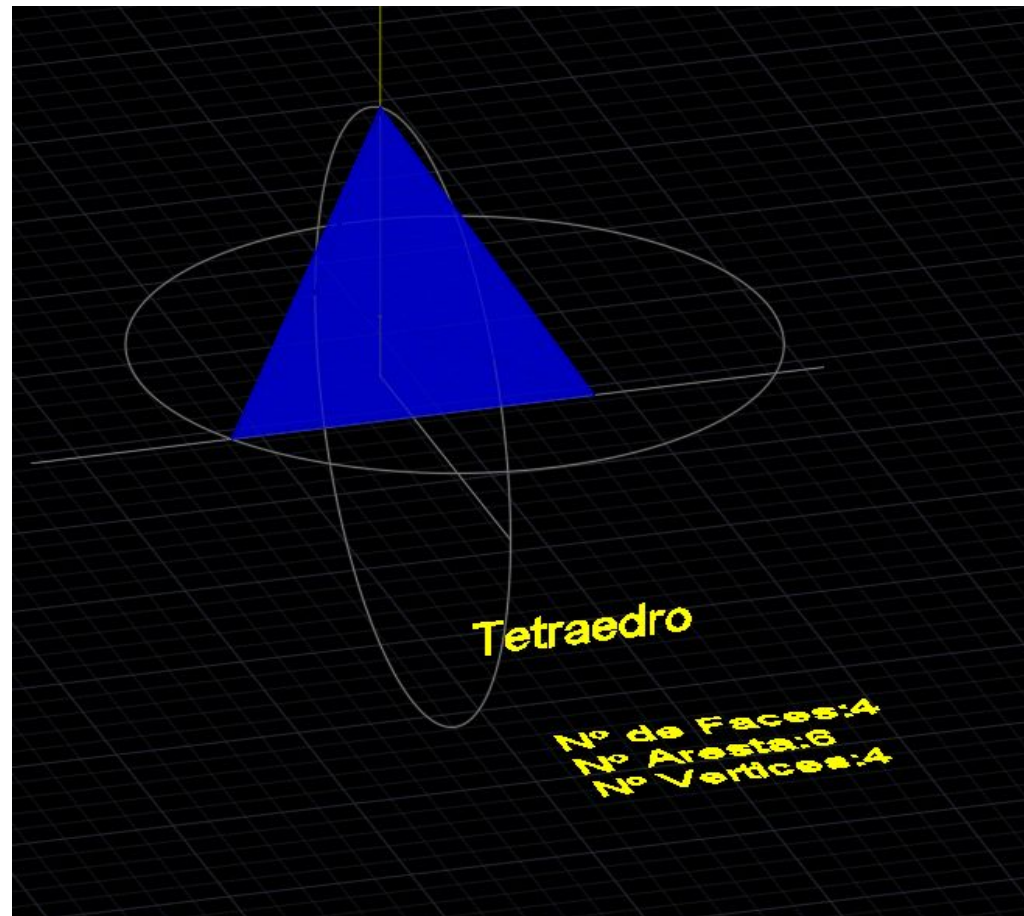

# Exerc. 5.2 - Figuras

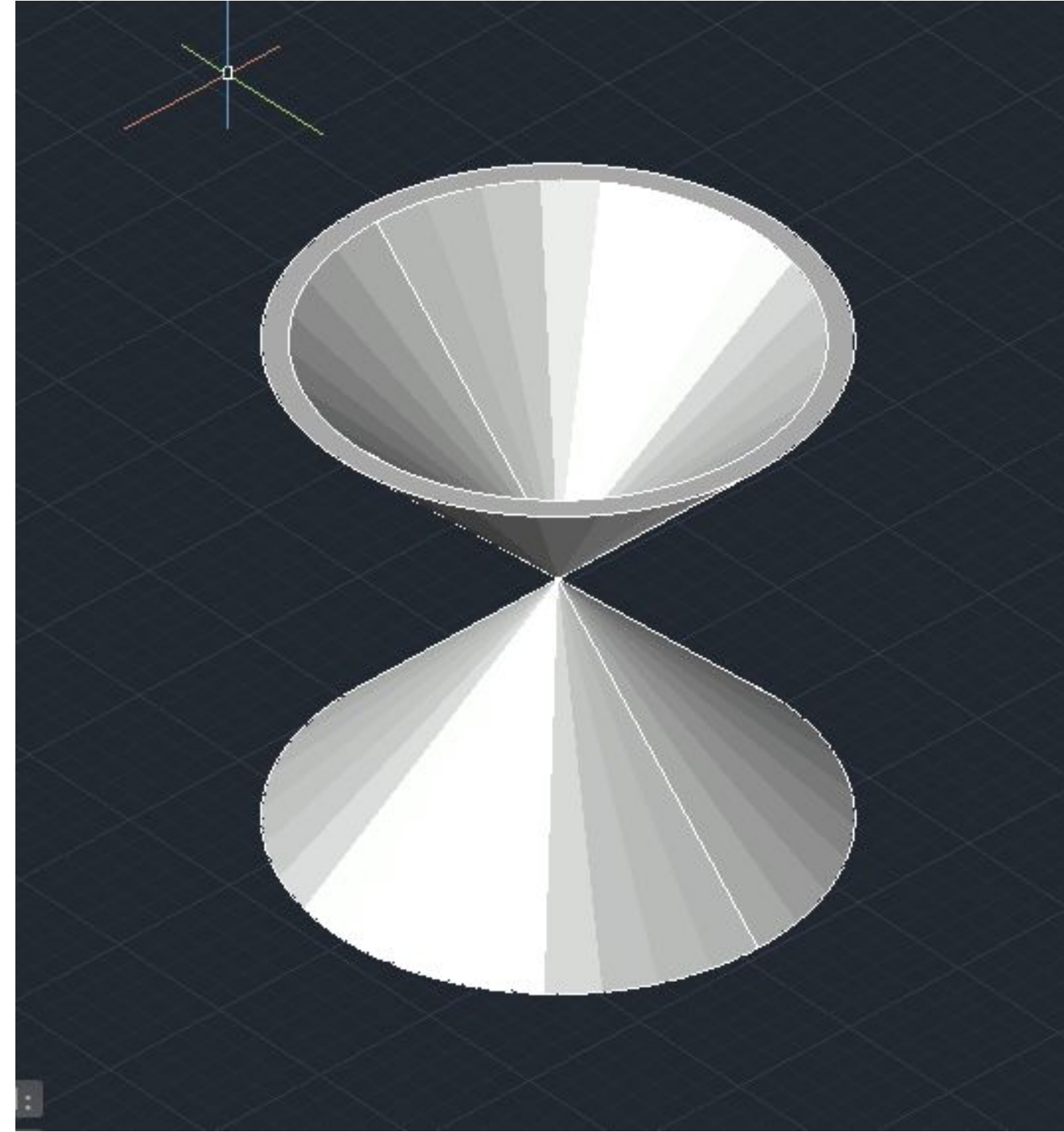
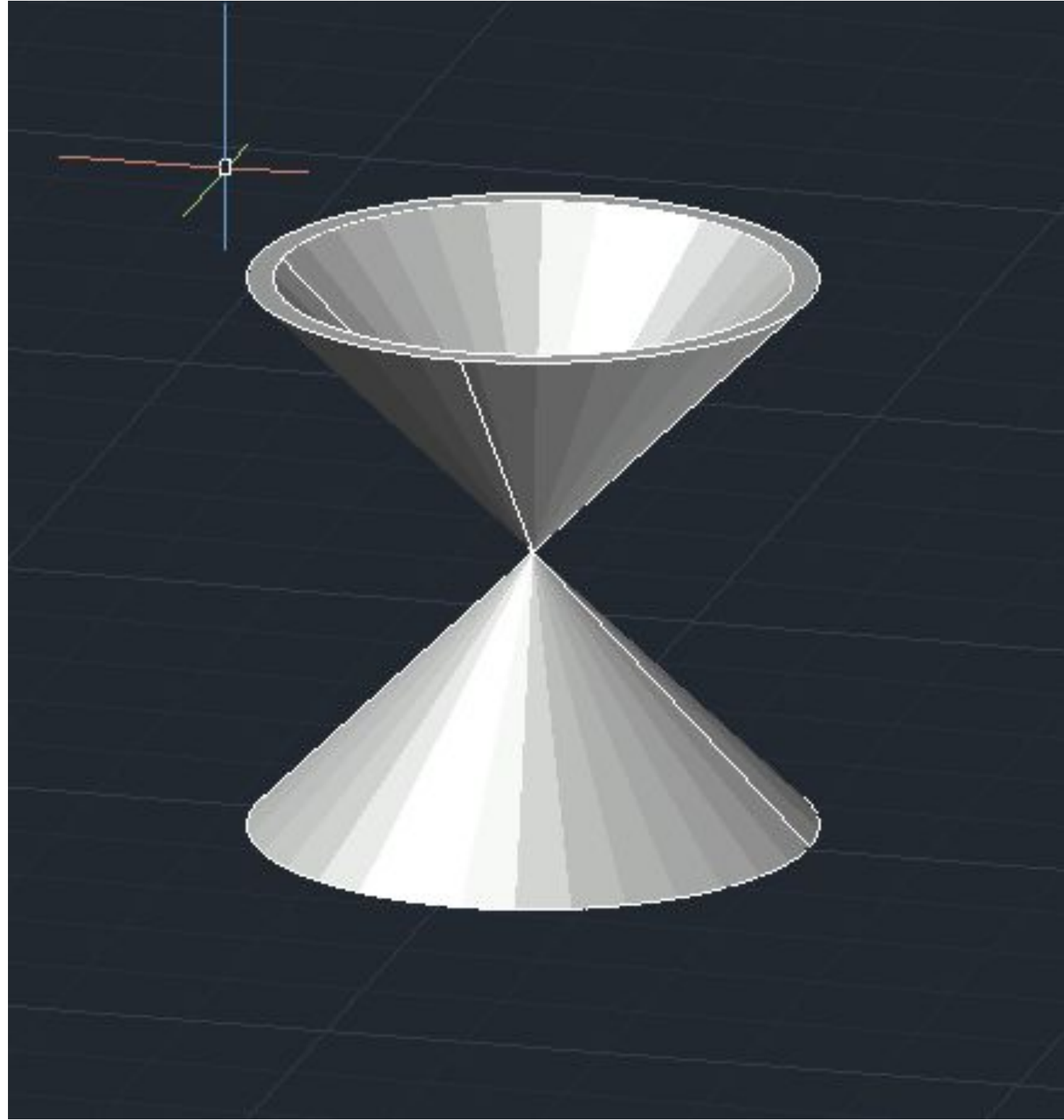

Exerc. 6.0 - Cone (Subtract)

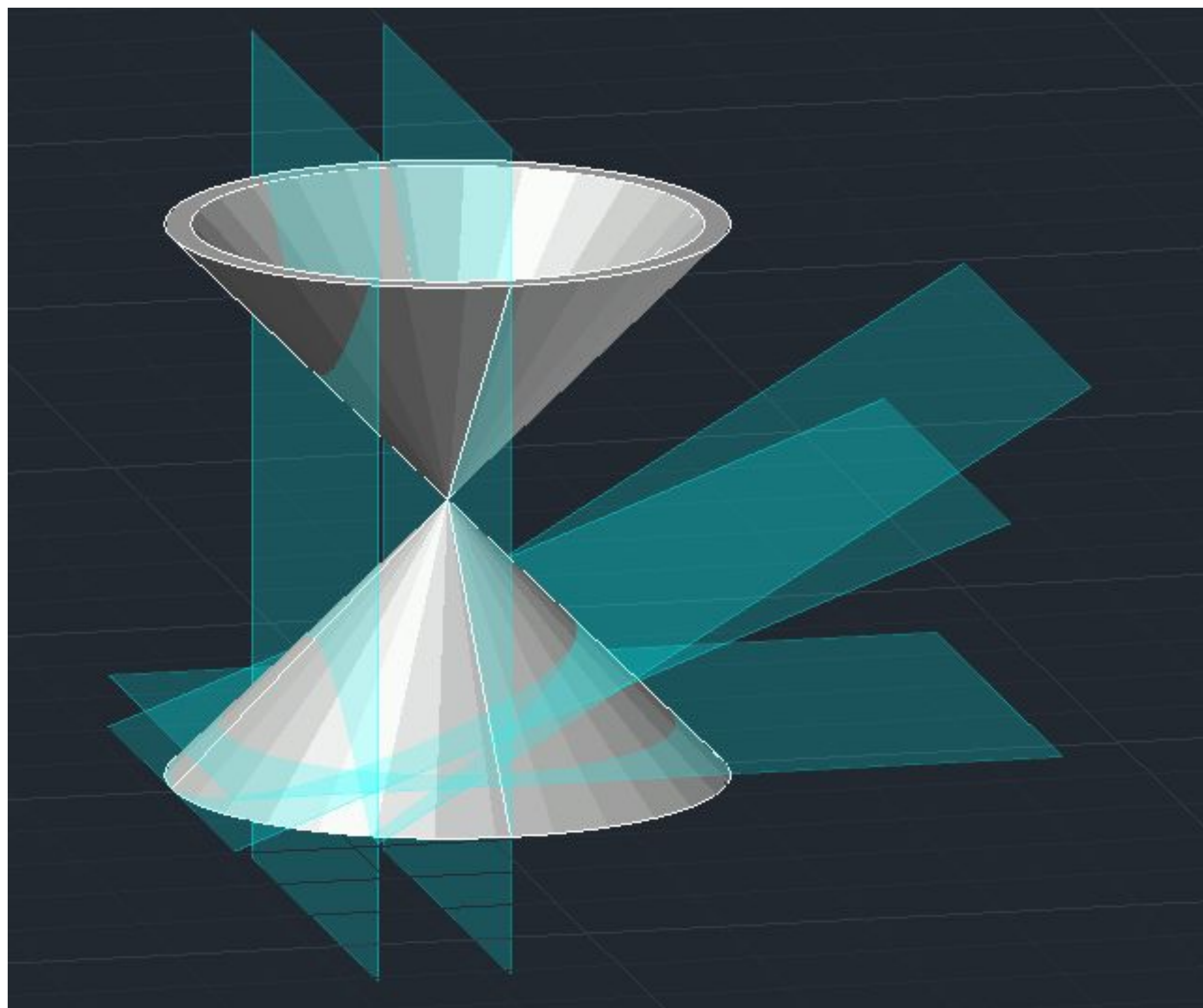

Exerc. 6.1 - Planos Secantes

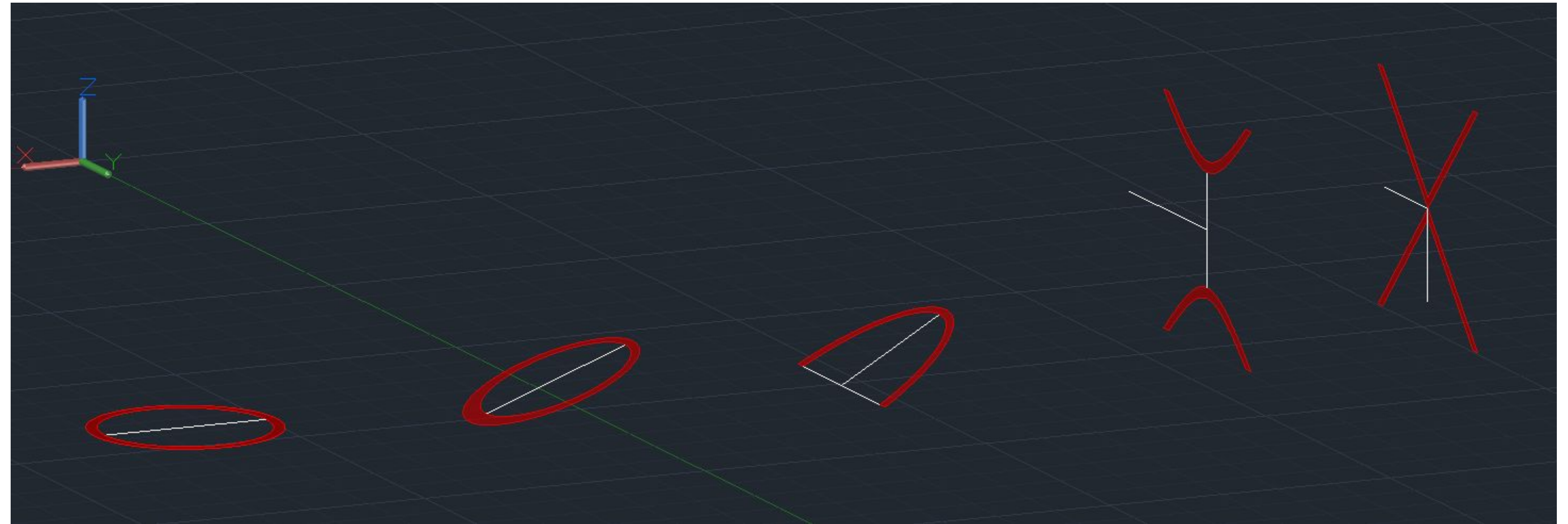
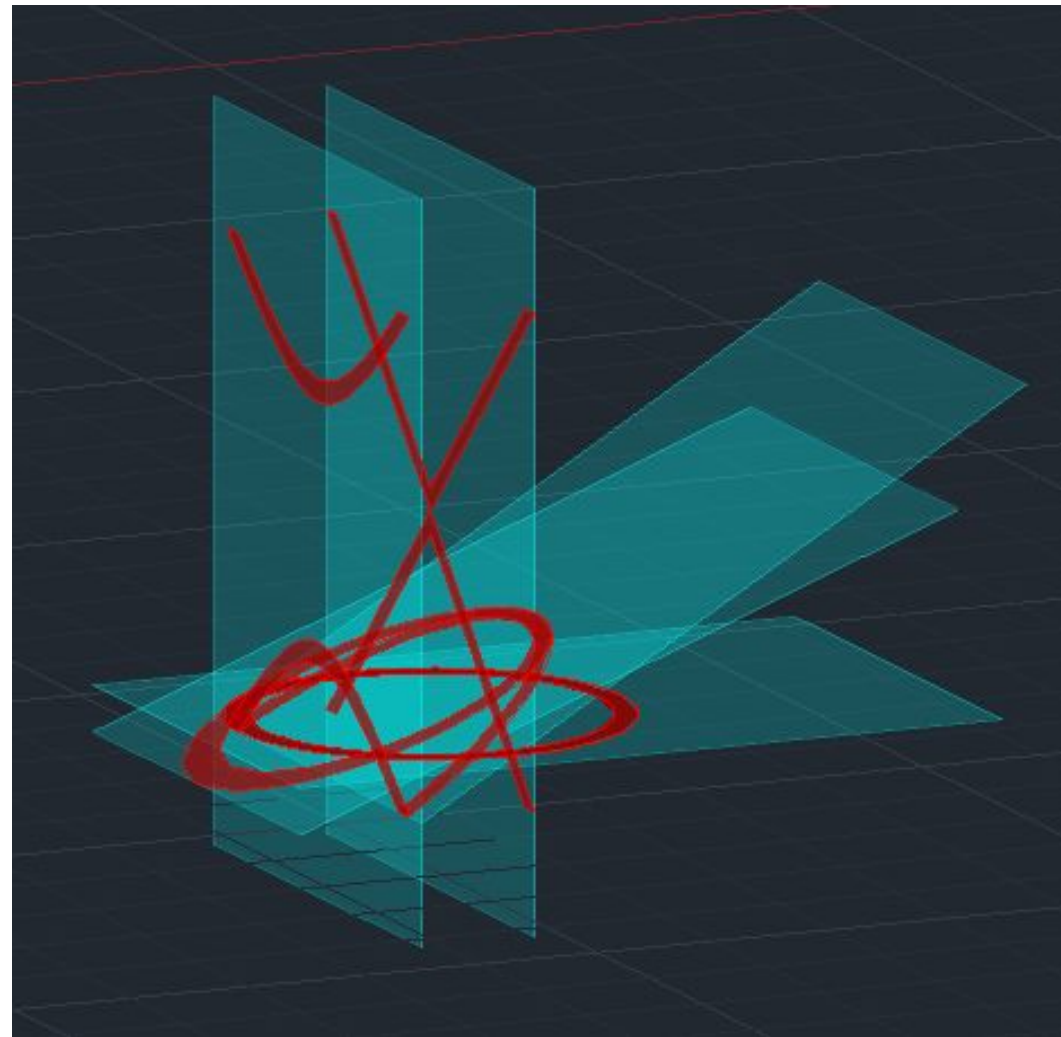
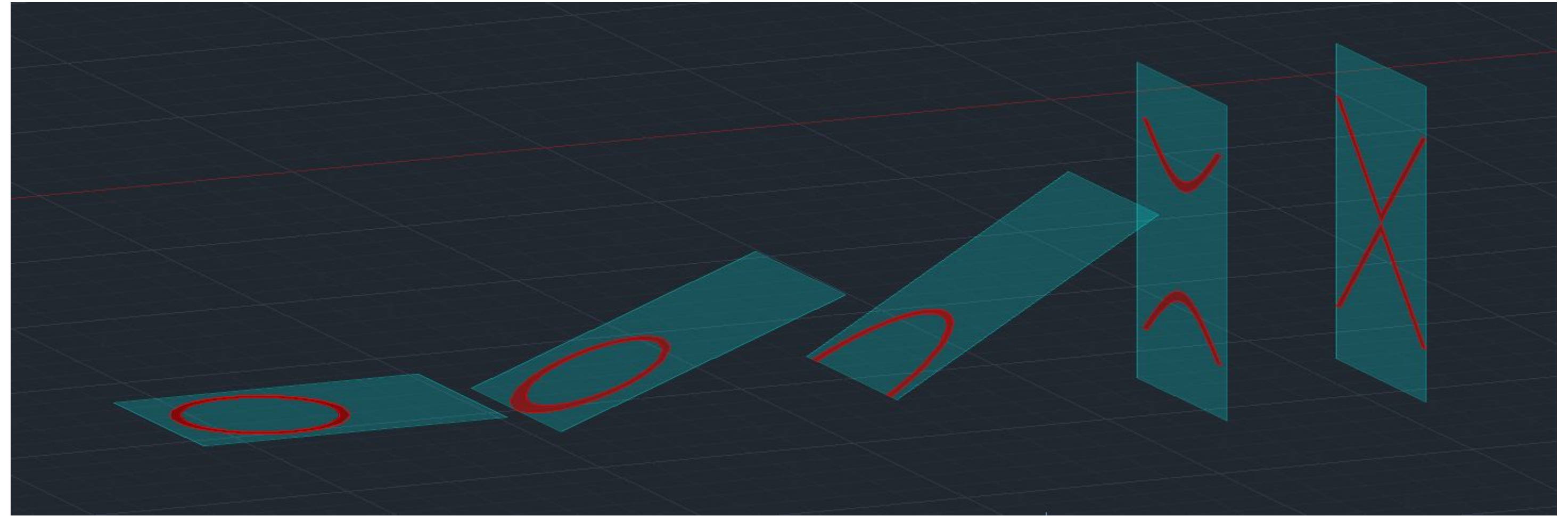
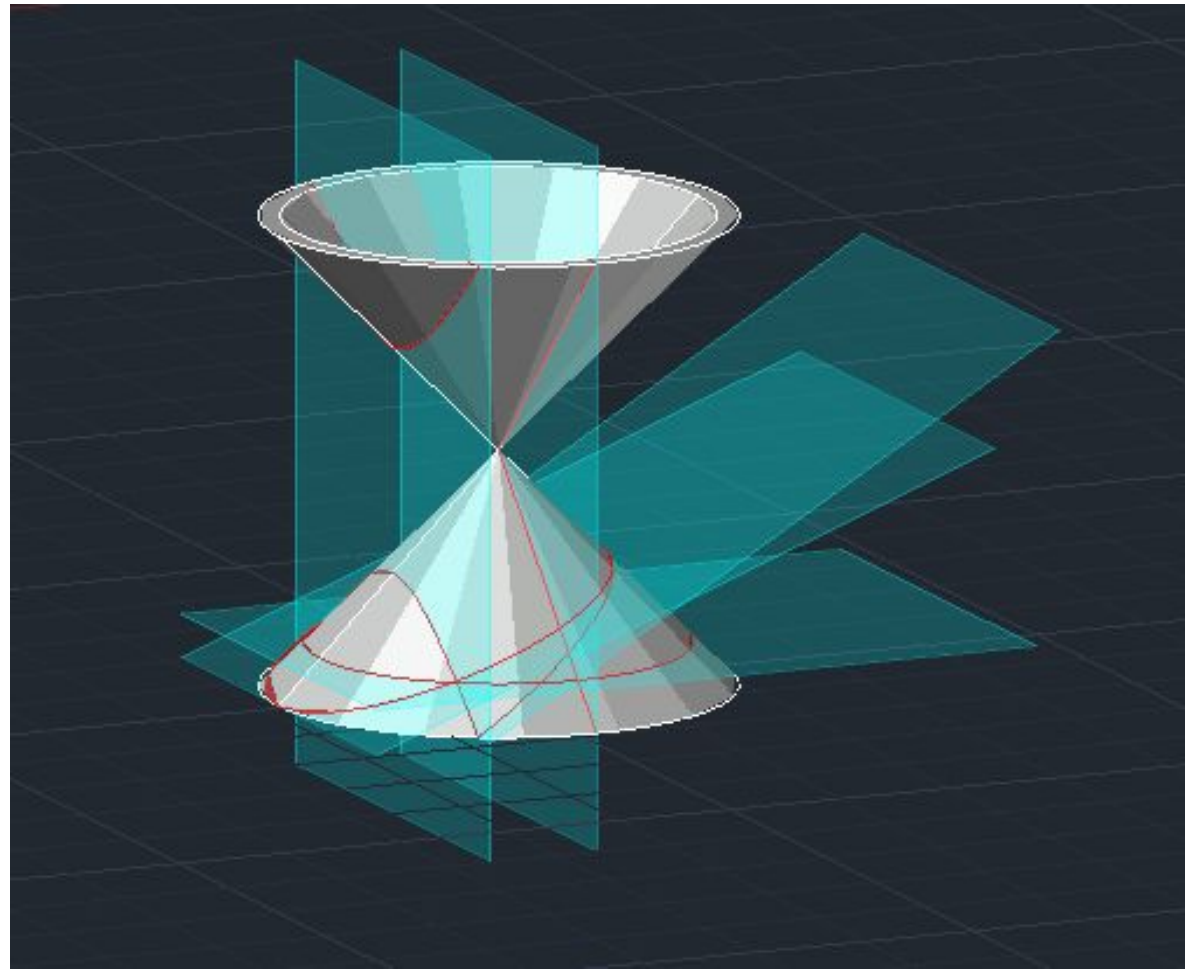

Exerc. 6.2 - Malha



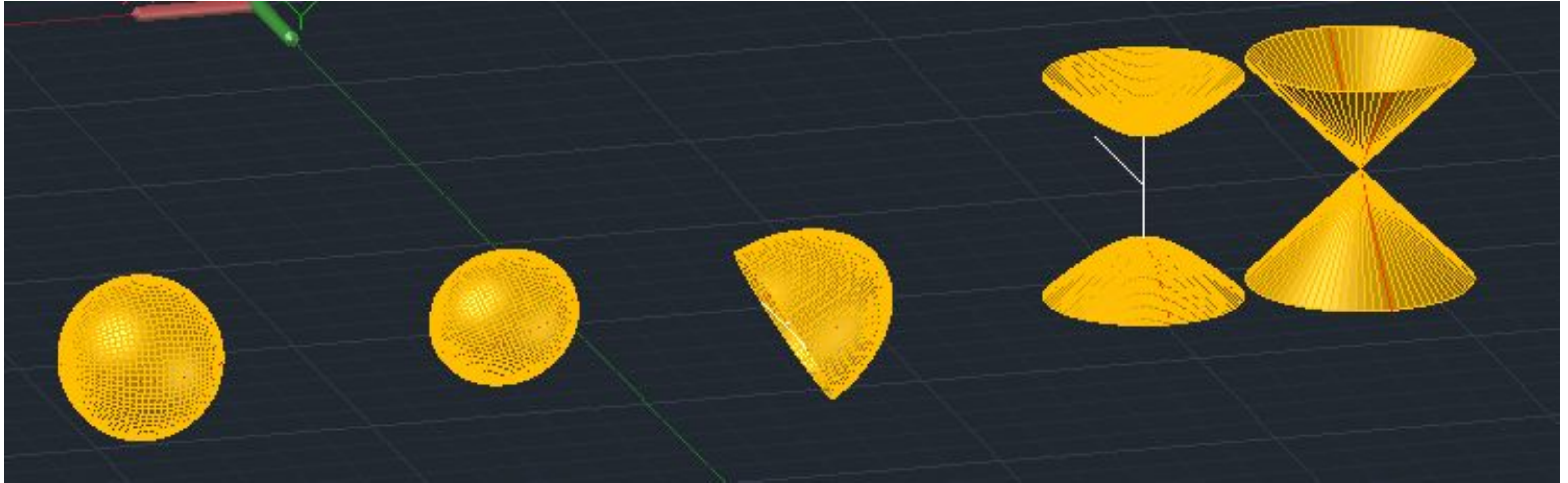

Exerc. 6.3 - Malha

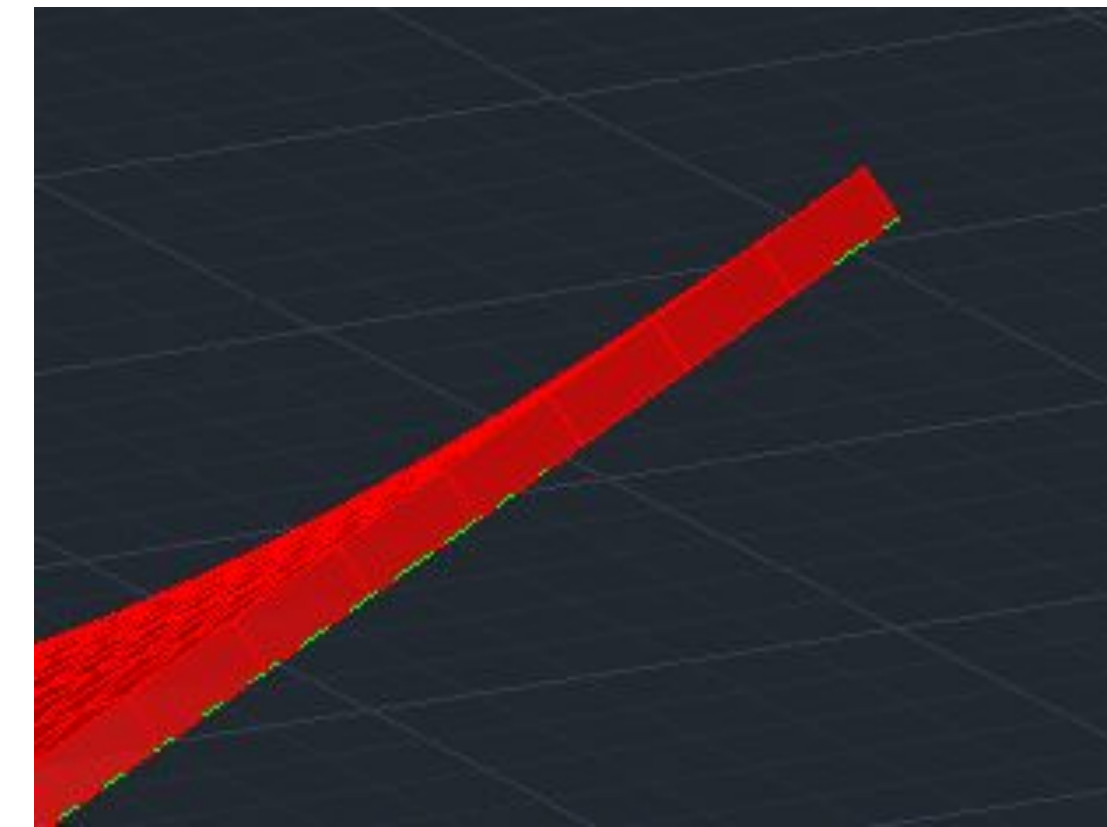
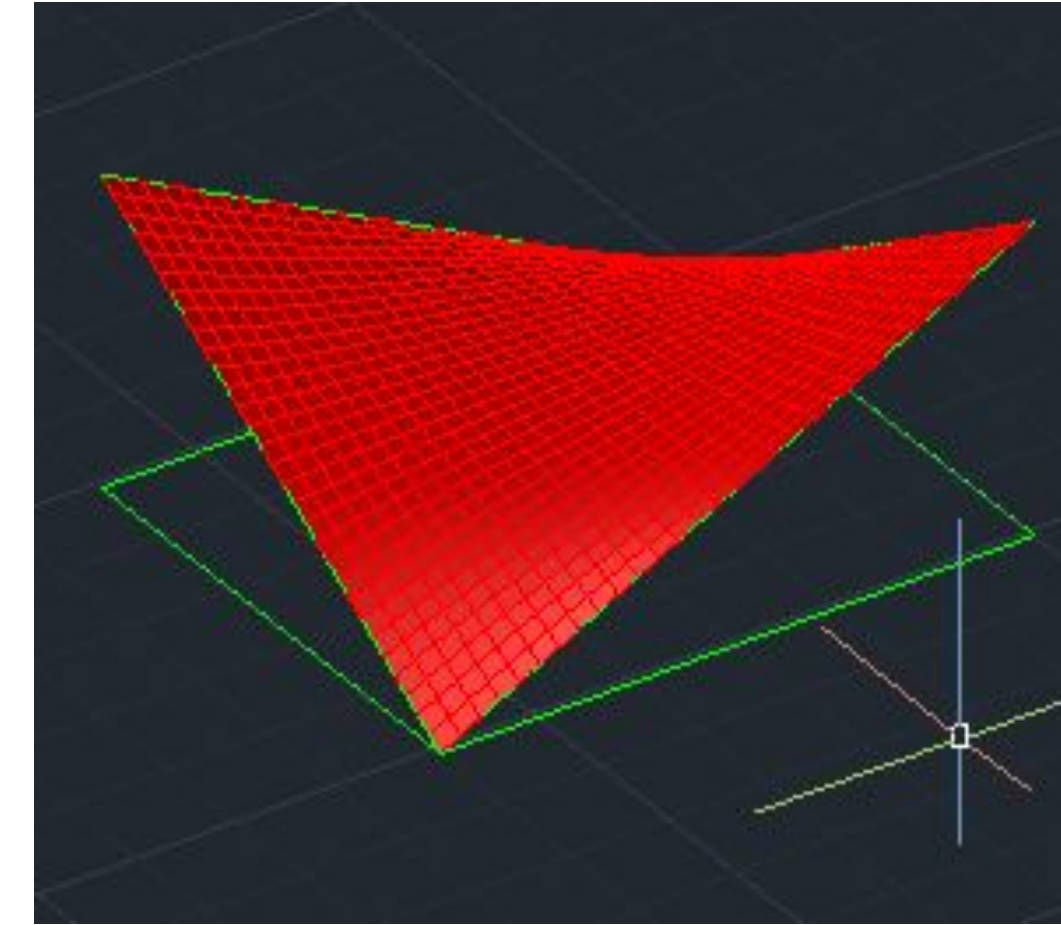
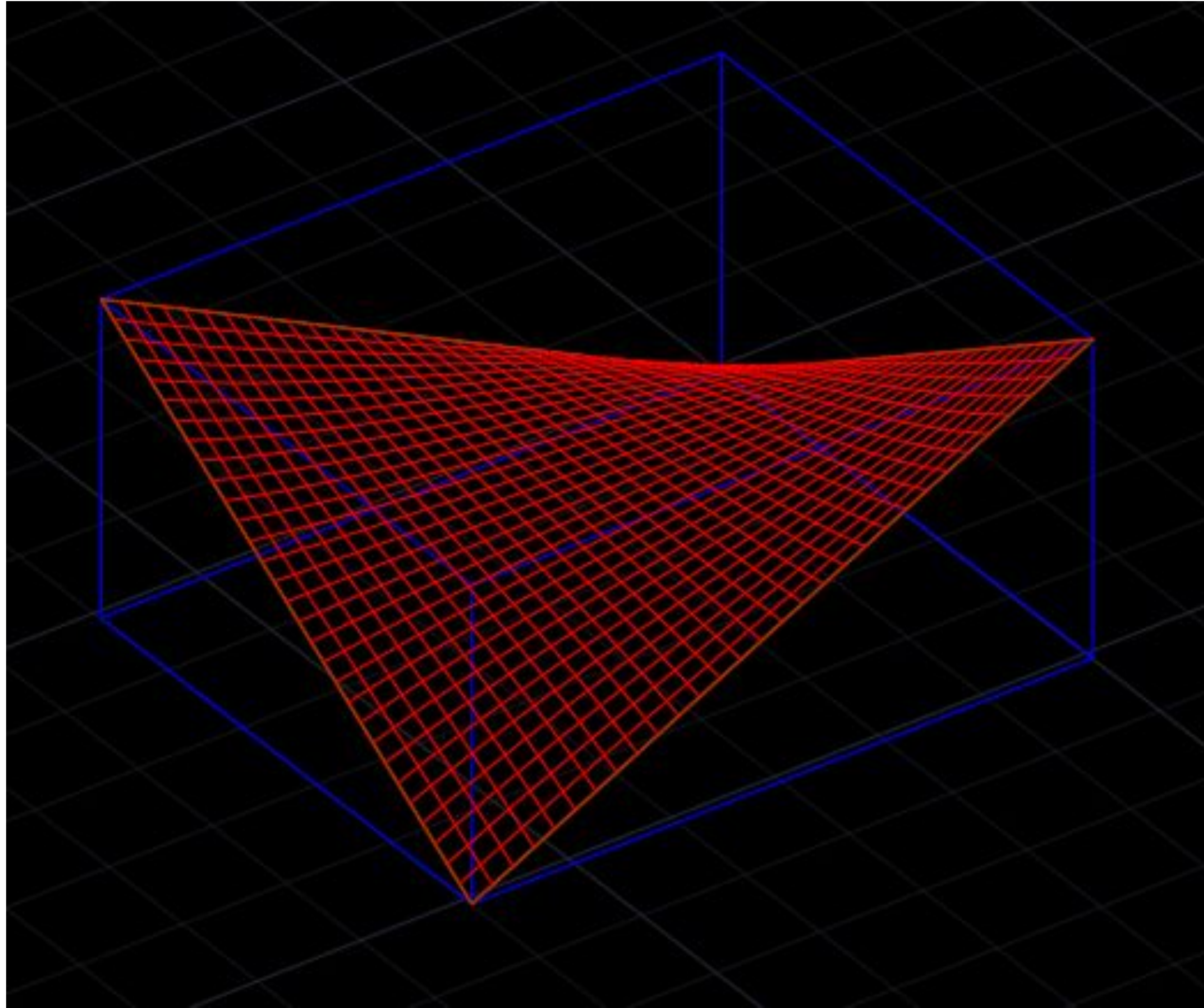

Exerc. 7.0 - Parabolóide Hiperb.

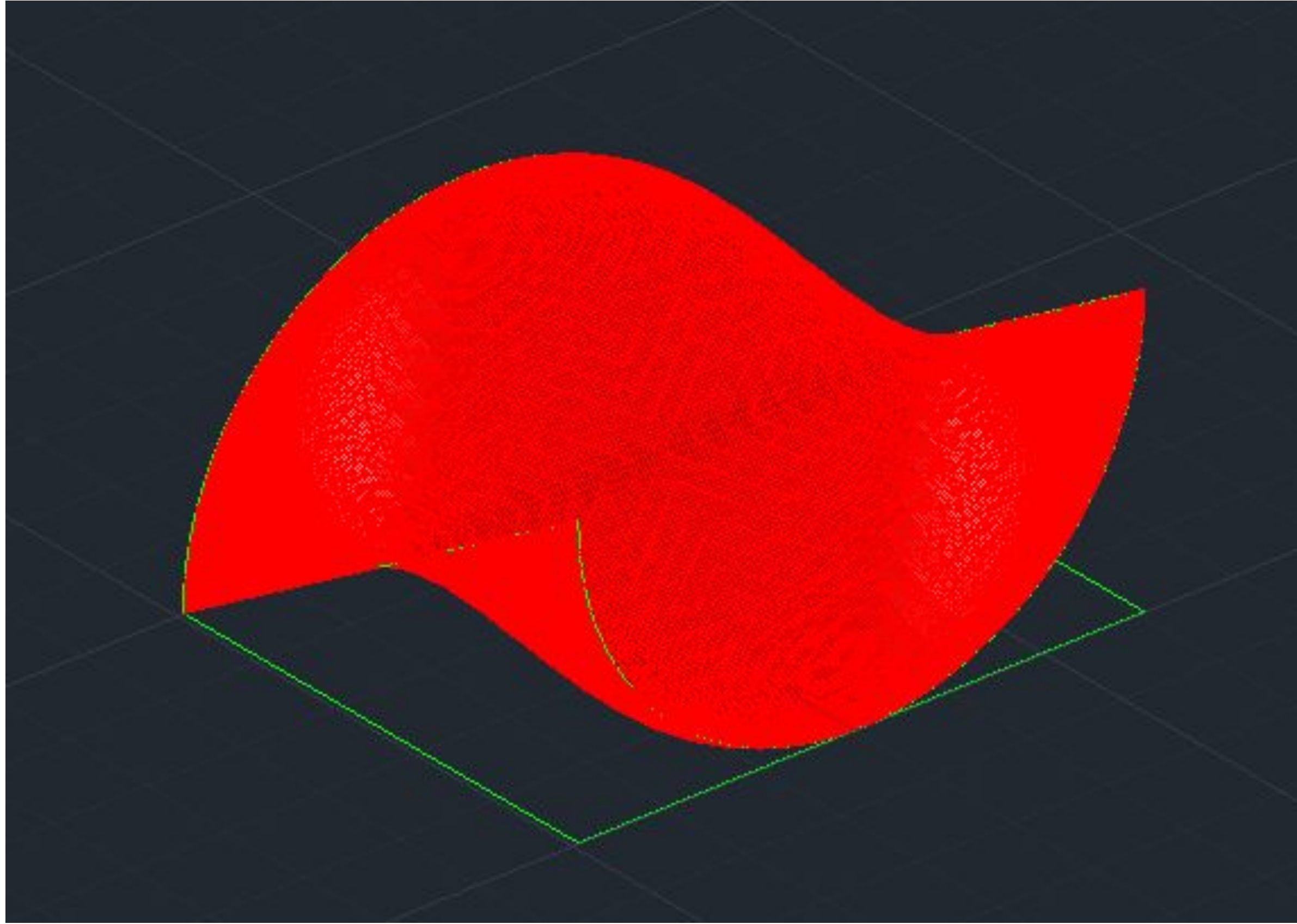

Exerc. 7.1 - Parabolóide Hiperb.

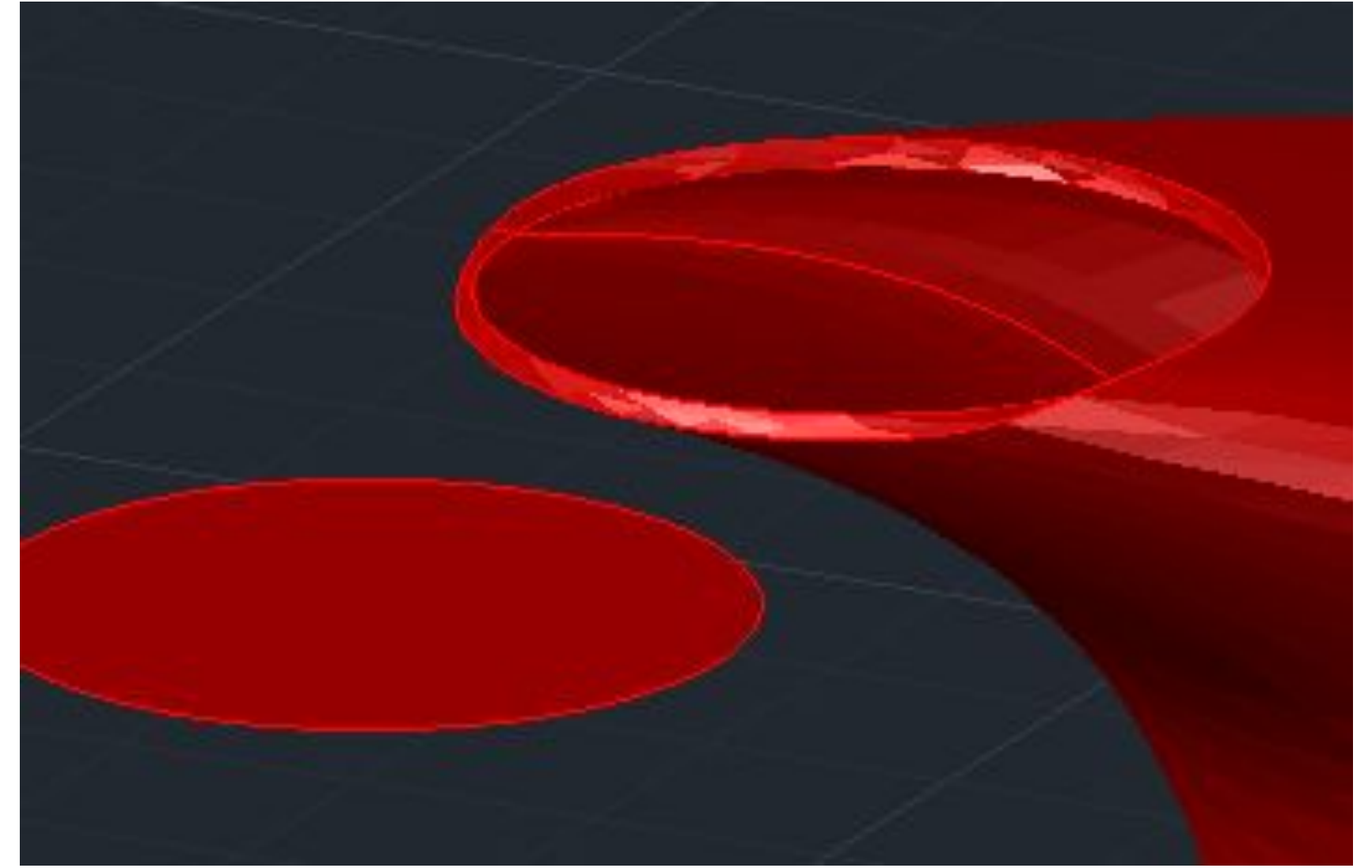
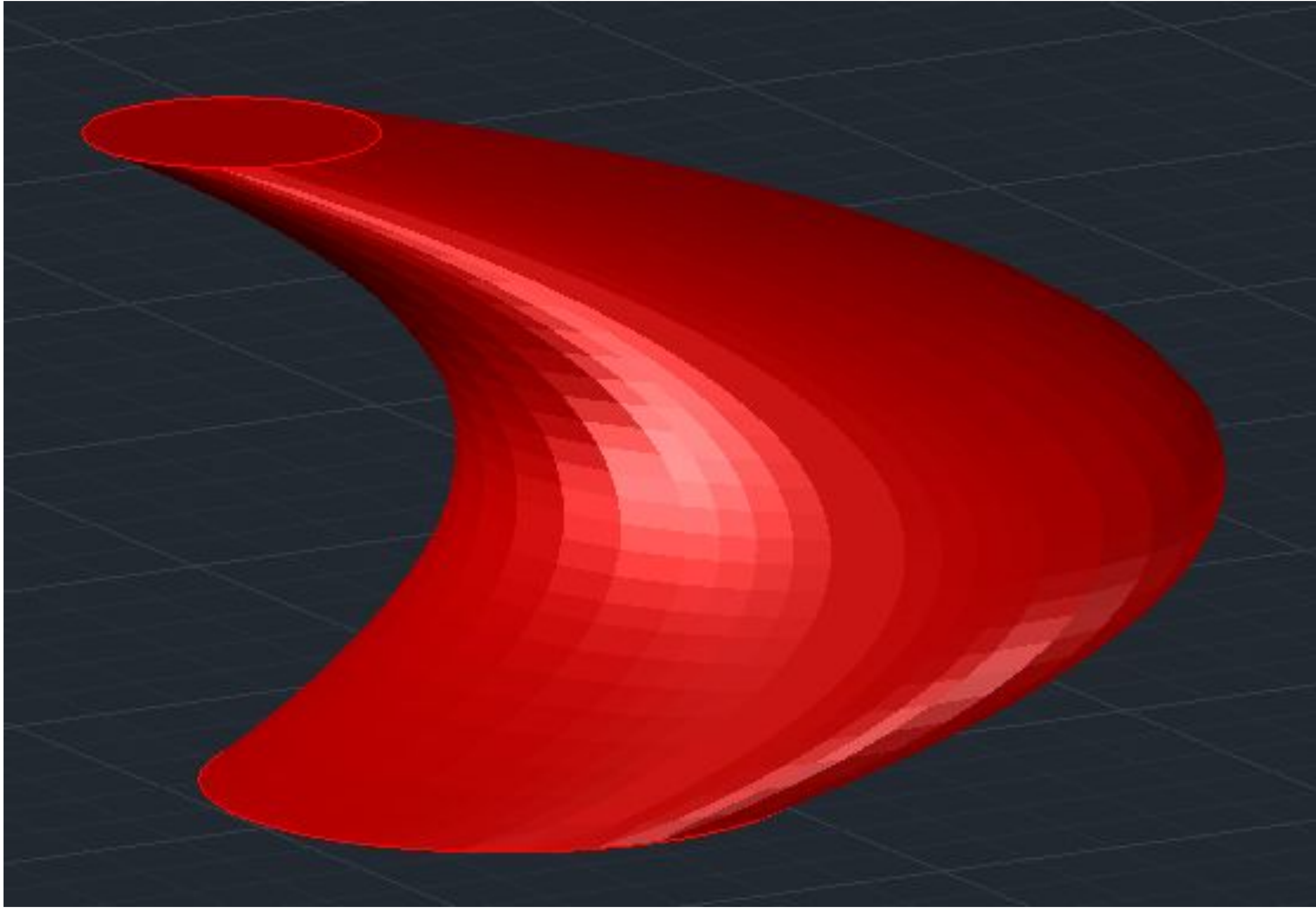

Exerc. 7.2

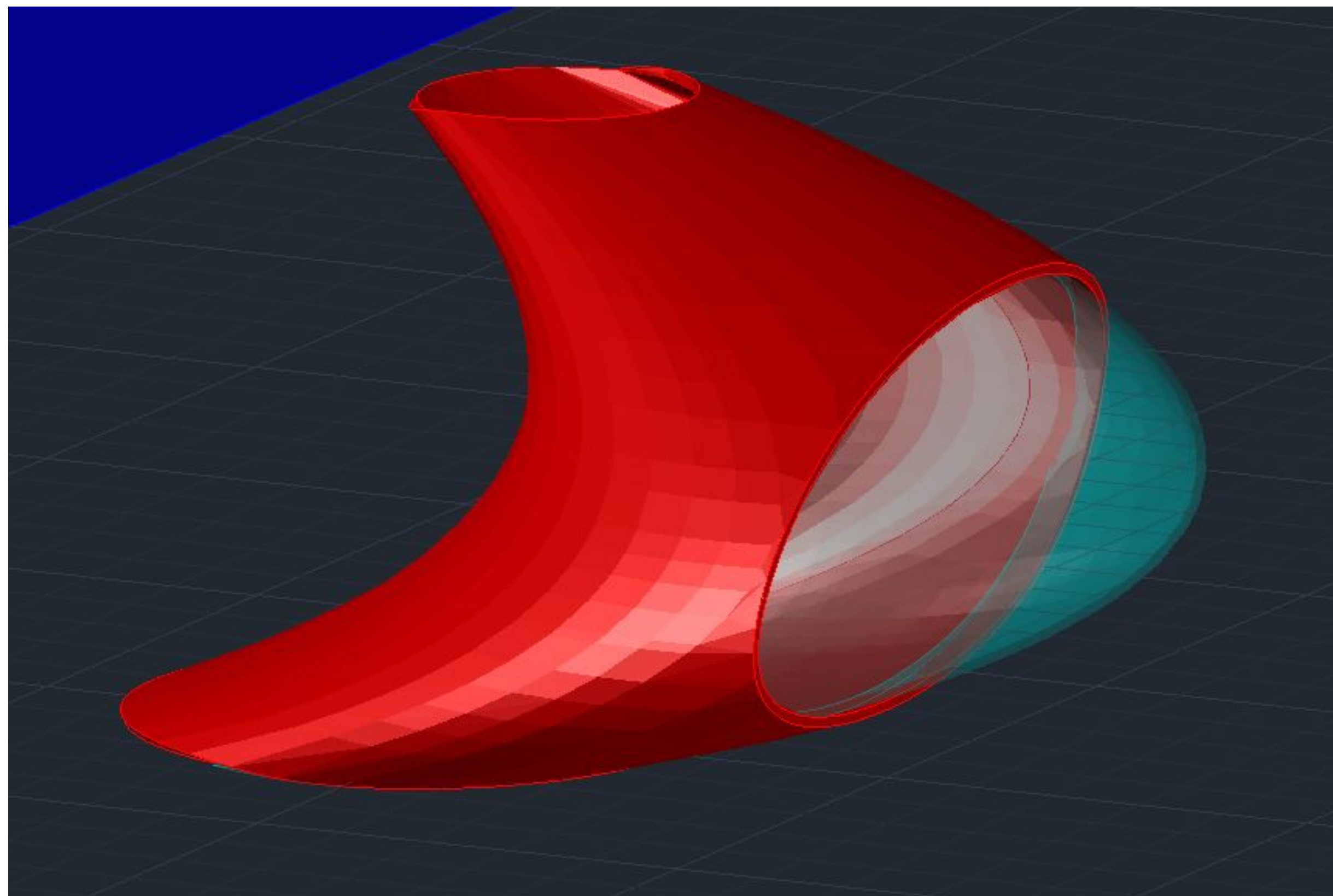

Exerc. 7.3

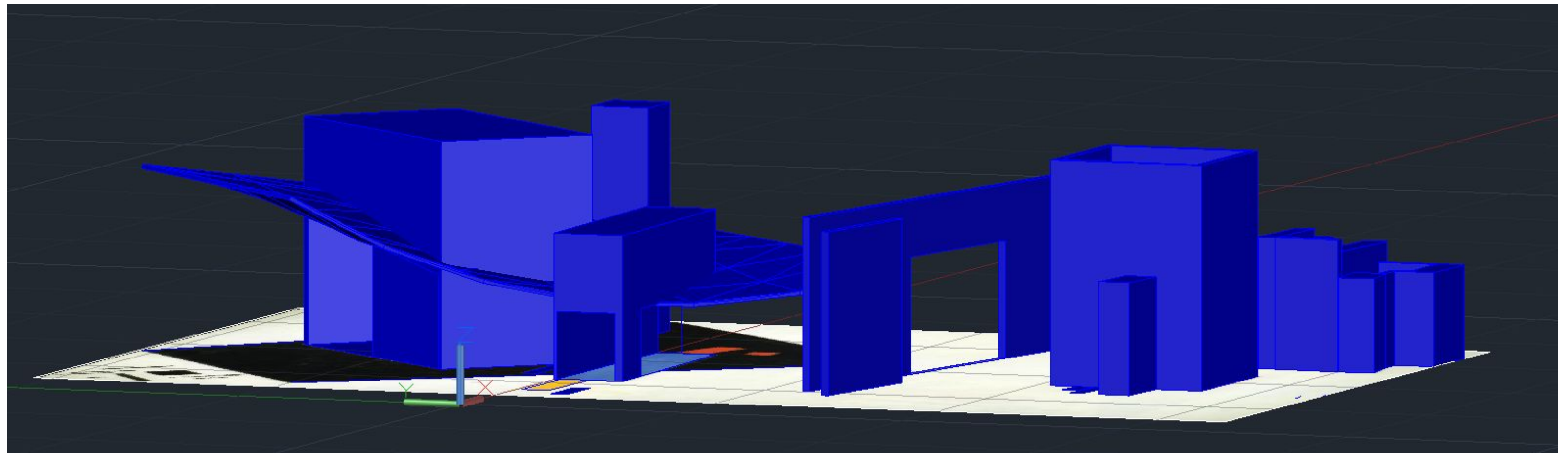
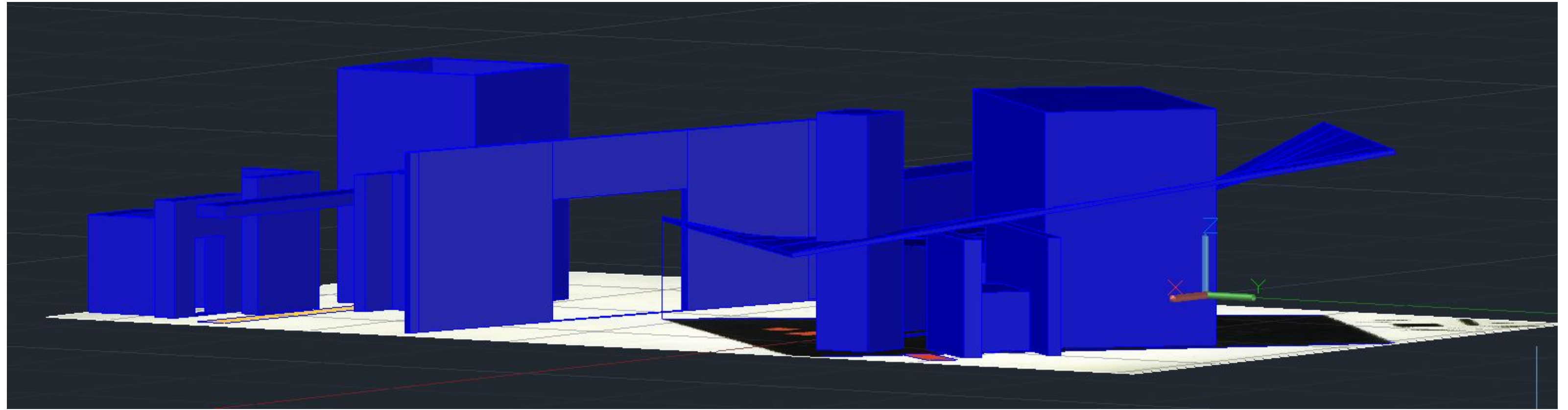
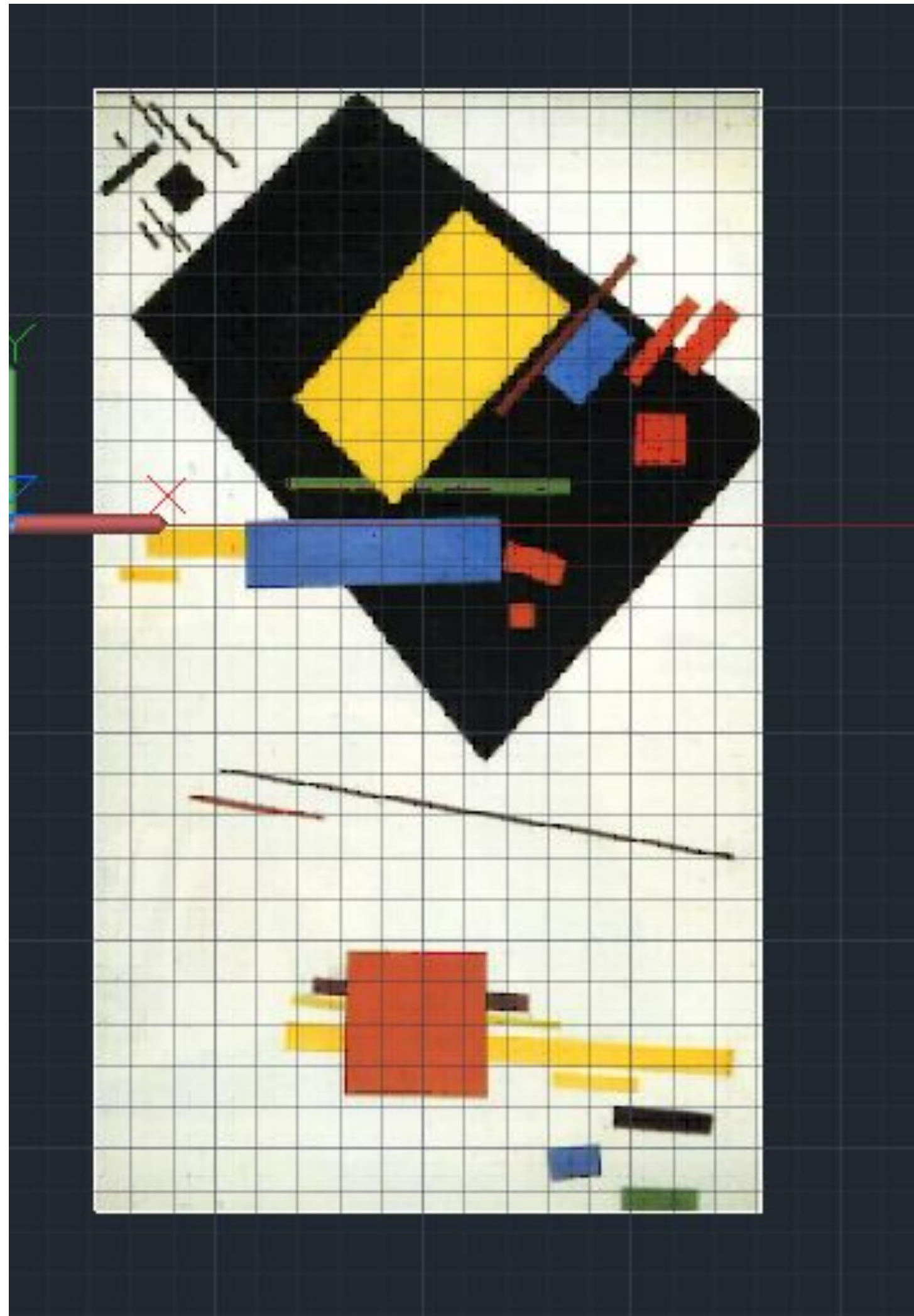

Exerc. 8.0 - Museu

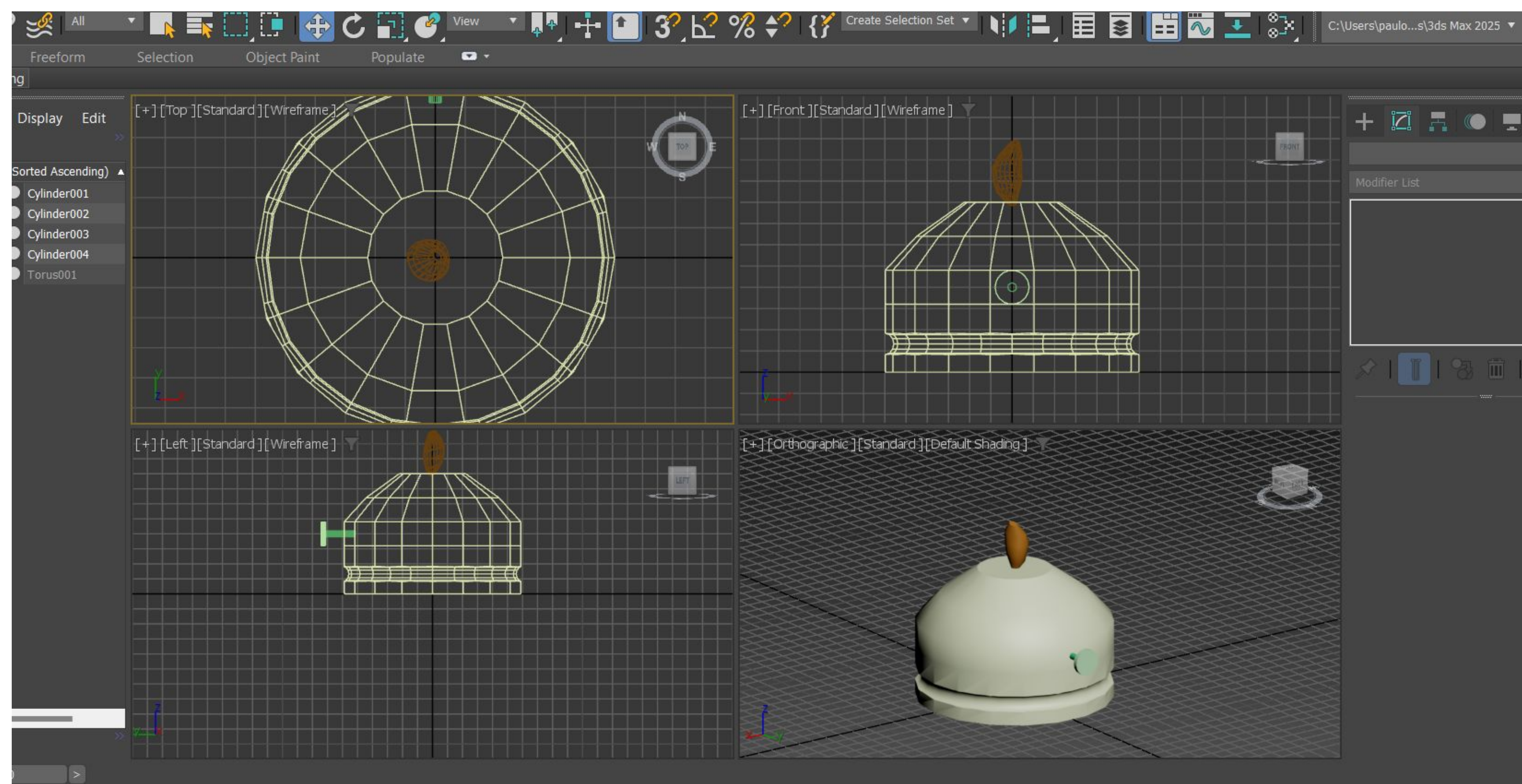

# Exerc. 9.0 - Candeeiro

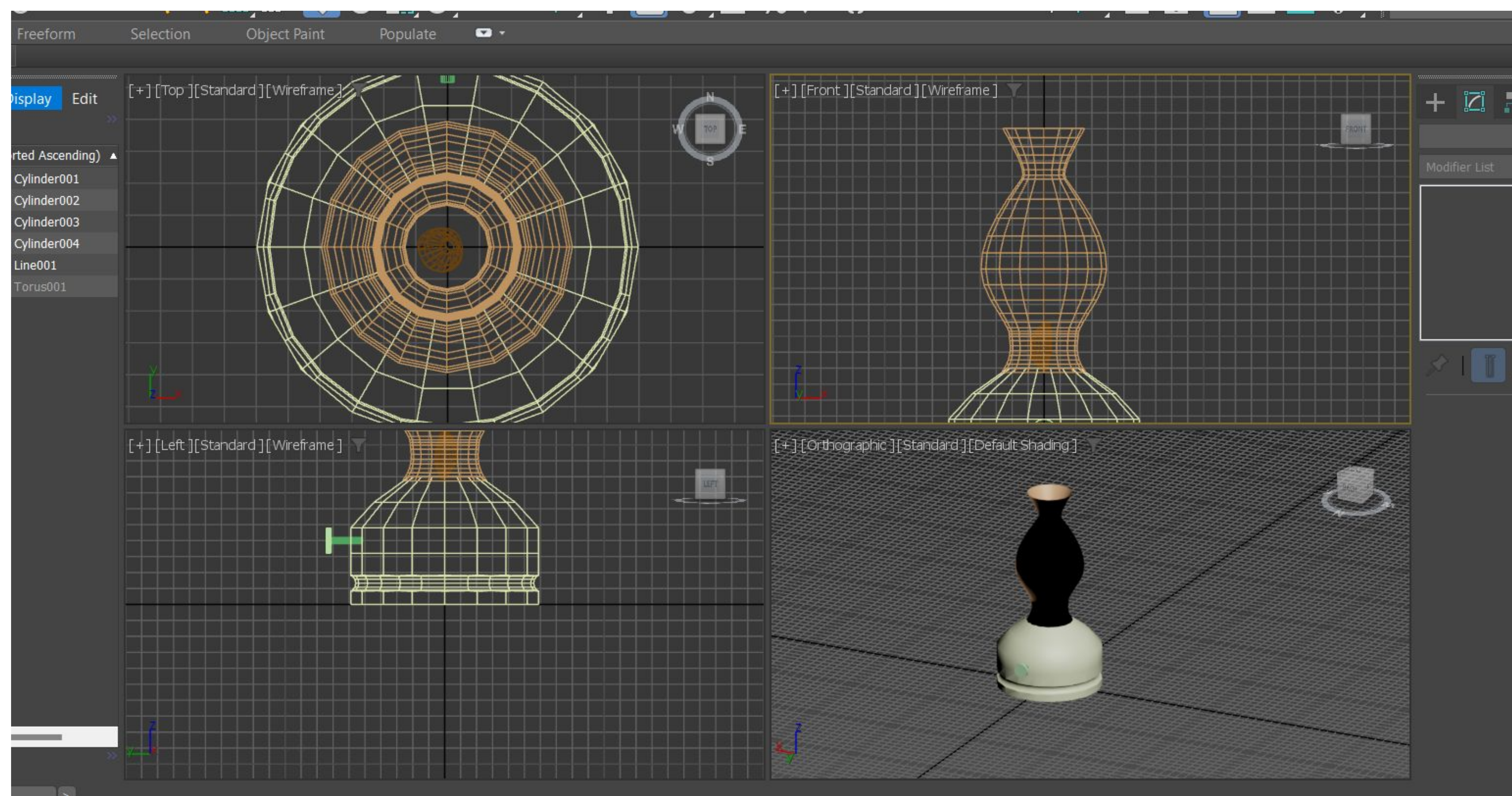

# Exerc. 9.1 - Candeeiro



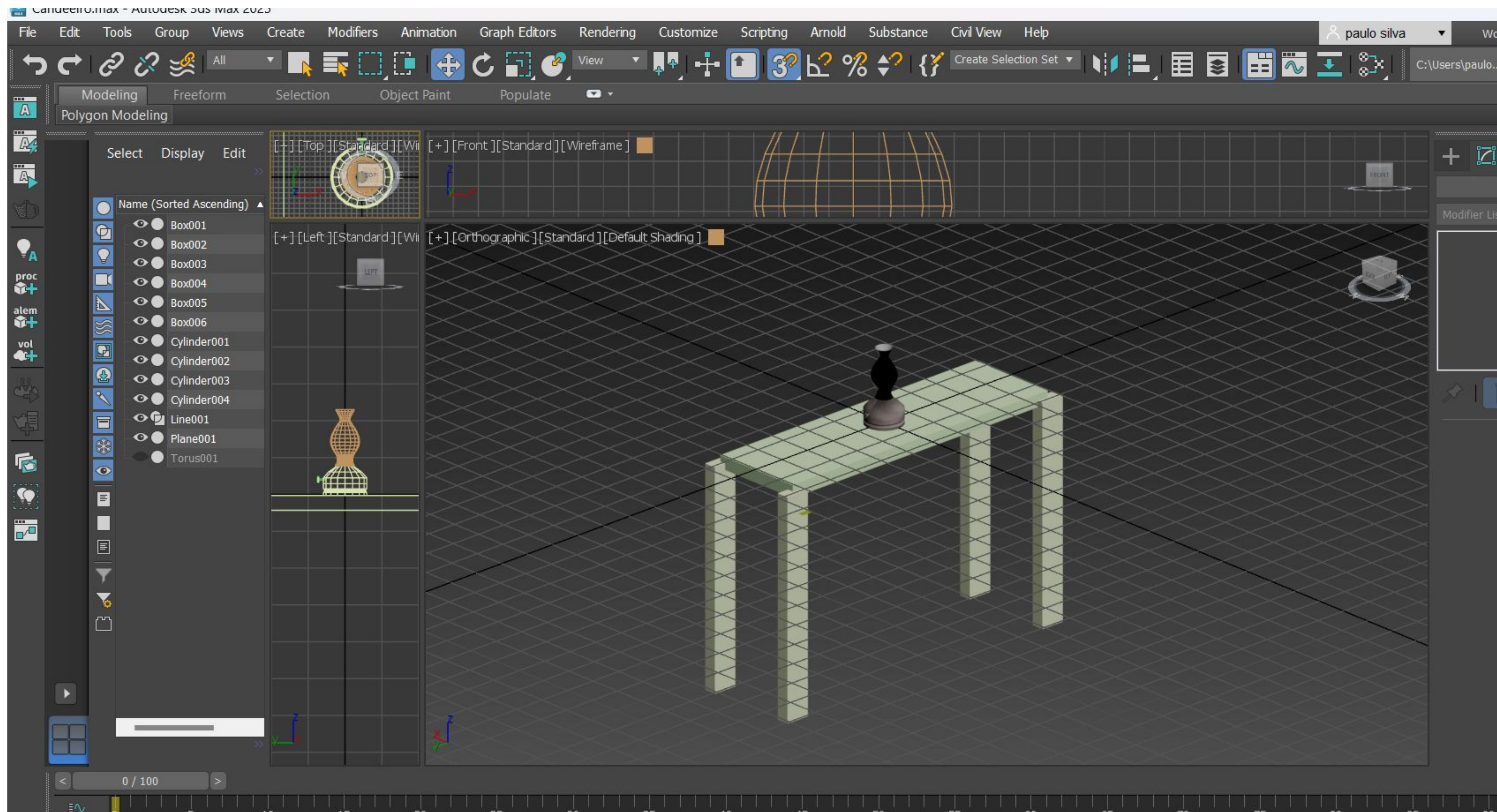

# Exerc. 9.2 - Candeeiro e mesa

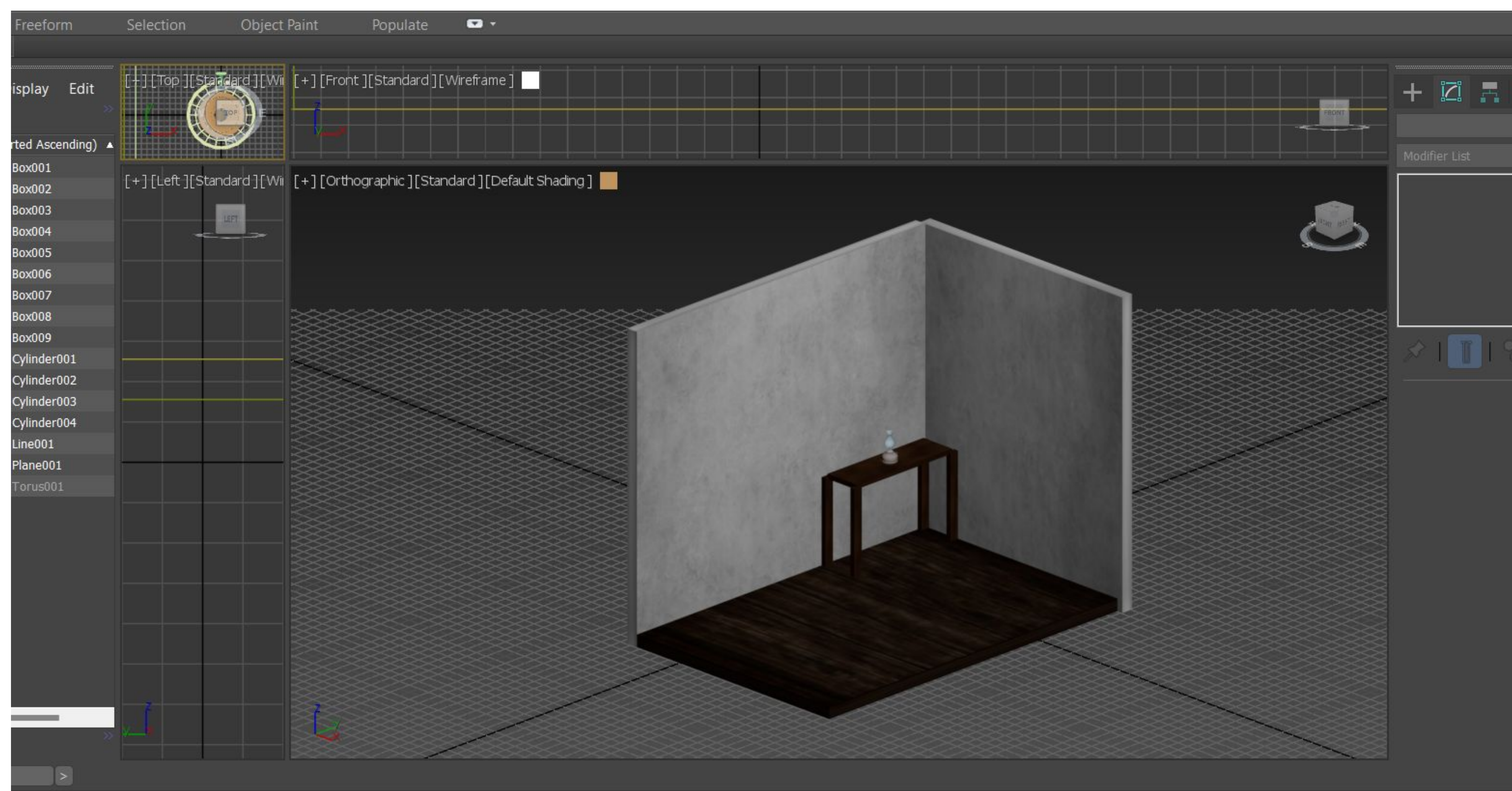

# Exerc. 9.3 - Cenário

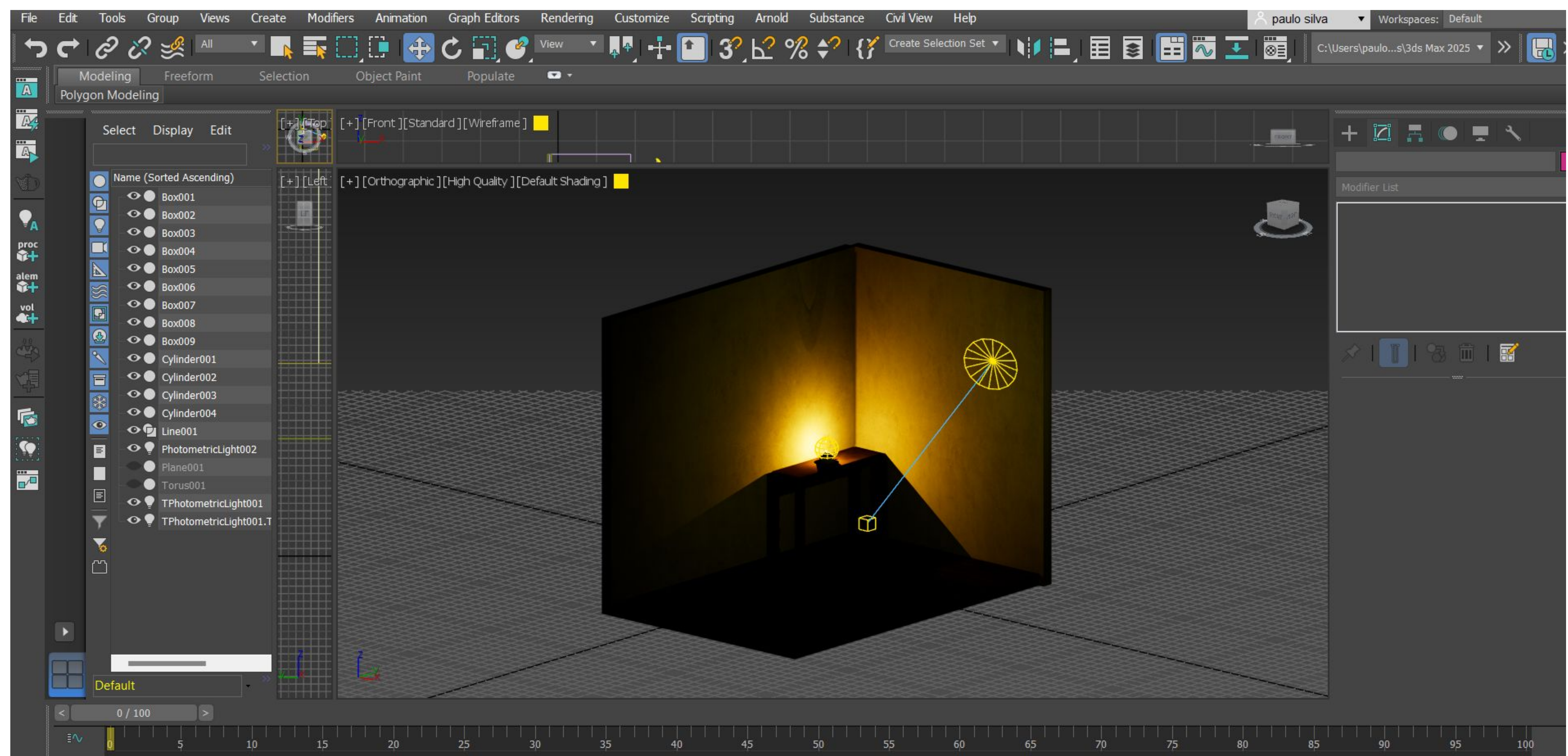

# Exerc. 9.4 - Iluminação

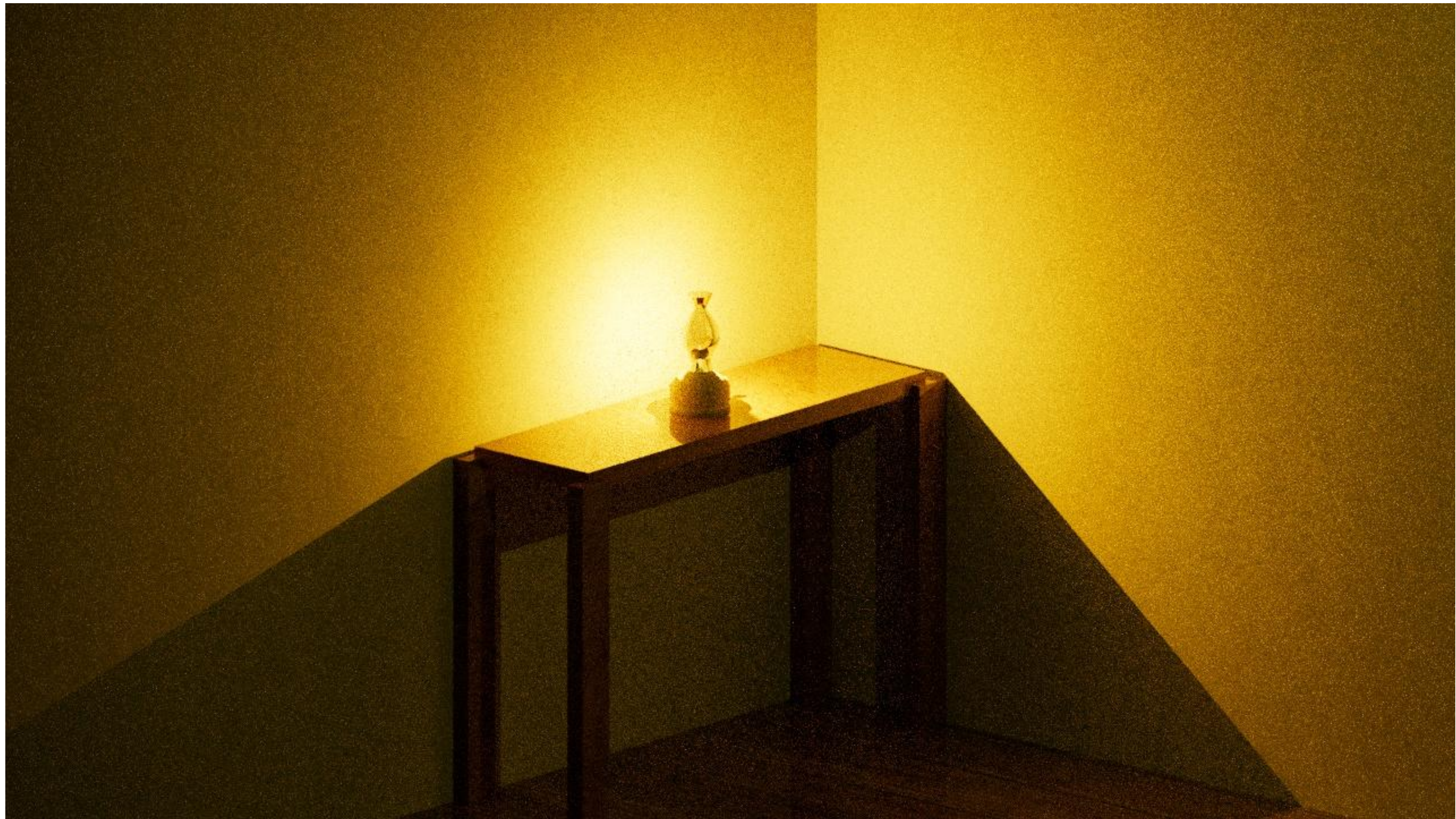

Exerc. 9.5 - Renderização

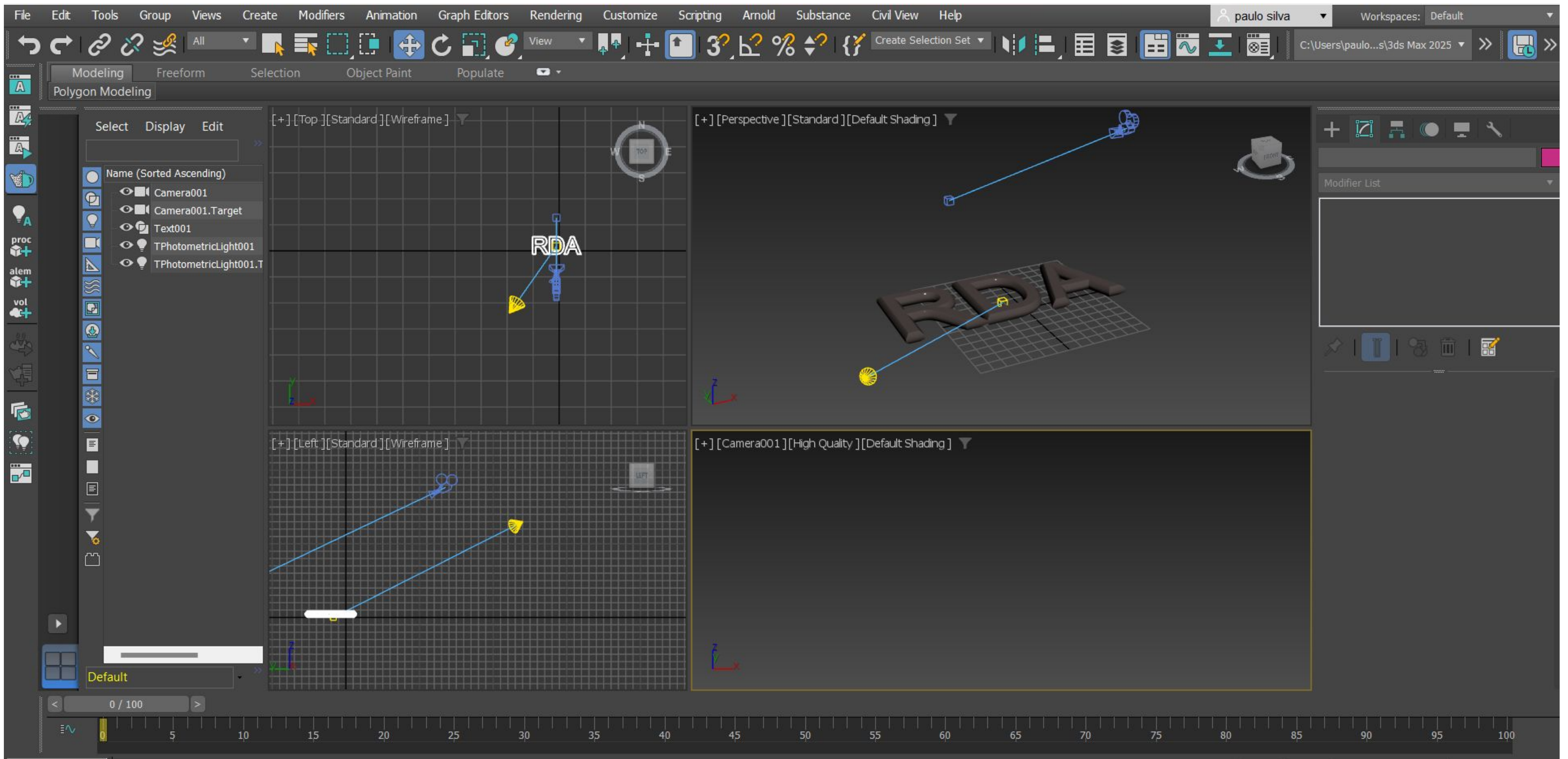

# Exerc. 10.0 - Animação

Exerc. 7.0 - Parabolóide Hiperb.

Exerc. 7.0 - Parabolóide Hiperb.

Exerc. 7.0 - Parabolóide Hiperb.



Exerc. 7.0 - Parabolóide Hiperb.

Exerc. 7.0 - Parabolóide Hiperb.

Exerc. 7.0 - Parabolóide Hiperb.

Exerc. 7.0 - Parabolóide Hiperb.

Exerc. 7.0 - Parabolóide Hiperb.

Exerc. 7.0 - Parabolóide Hiperb.