

# Modelação e Visualização Tridimensional em Arquitectura

# 20201344

SÉRGIO MARTINS



**U** LISBOA

UNIVERSIDADE  
DE LISBOA



FACULDADE DE ARQUITETURA  
UNIVERSIDADE DE LISBOA

# MVTA

Mestrado Integrado em Arquitectura  
Ano Lectivo 2022-2023 2º Semestre  
Docente - Nuno Alão 3º Ano

## ÍNDICE

Exerc. 1.1 e 1.2 - Superfície Parabólica .....	pág. 4-5
Exerc. 2 – Sólidos Geométricos .....	pág. 6-11
Exerc. 3 – Secções em um Cone .....	pág. 12-15
Exerc. 4 – XADREZ .....	pág. 16
Exerc. 5 – Hiperboloide .....	pág. 17
Exerc. 6 – Superfícies curvas .....	pág. 18
Exerc. 7 – Hélix .....	pág. 19-20
Exerc. 8 – Guggenheim .....	pág. 21
Exerc. 9 – 3D MAX – Introdução .....	pág. 22
Exerc. 10 – 3D MAX – lâmpada .....	pág. 23
Exerc. 11 – 3D MAX – materiais .....	pág. 24-29
Exerc. 12 – 3D MAX – animação .....	pág. 30

PARÁBOLA | Superfície Parabólica

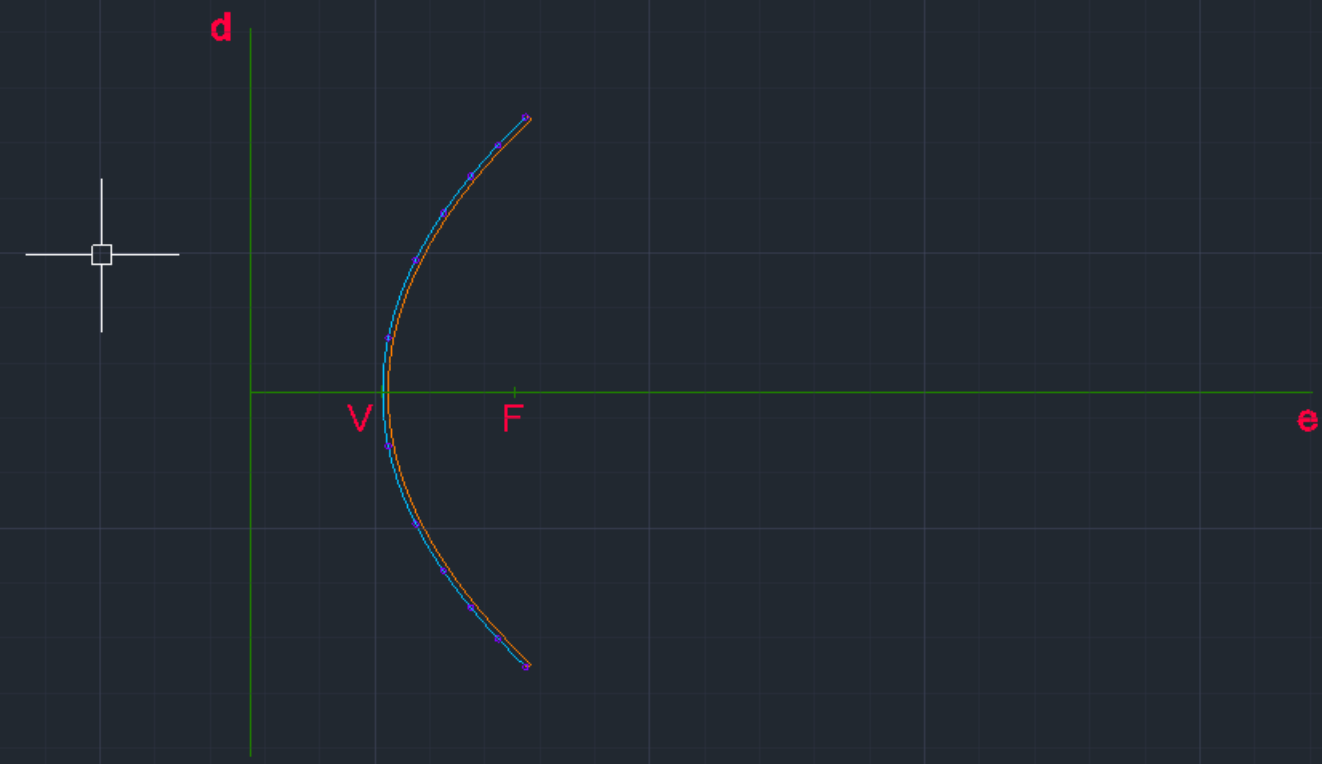

PARÁBOLA | Superfície Parabólica

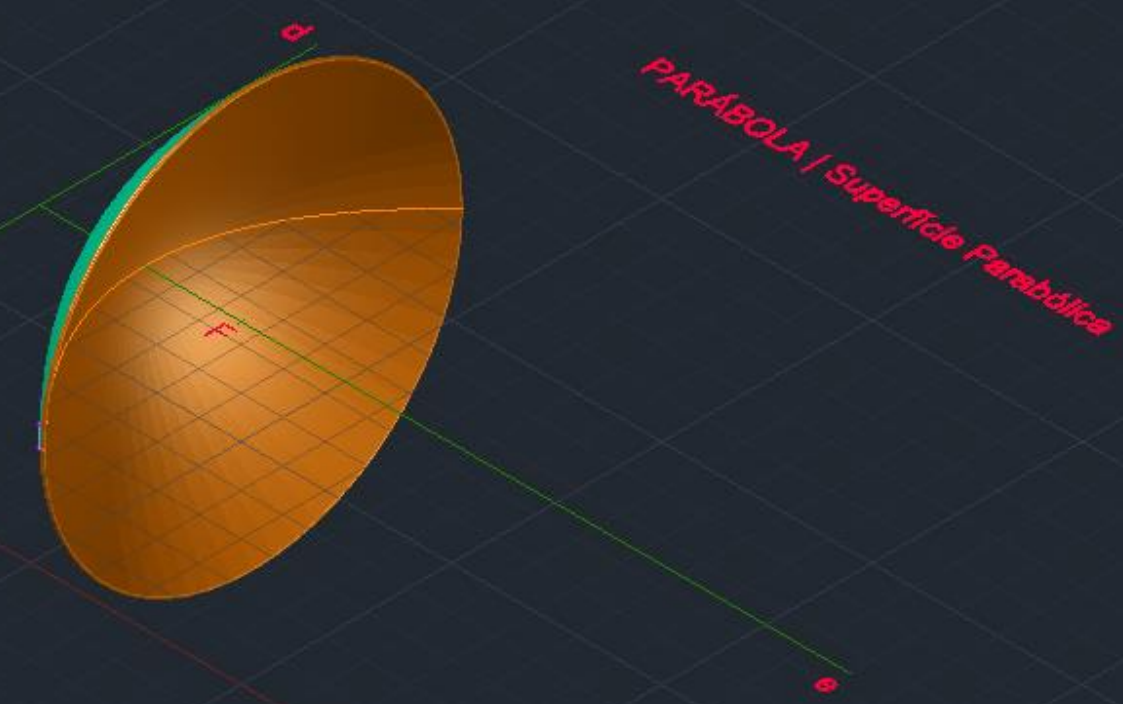
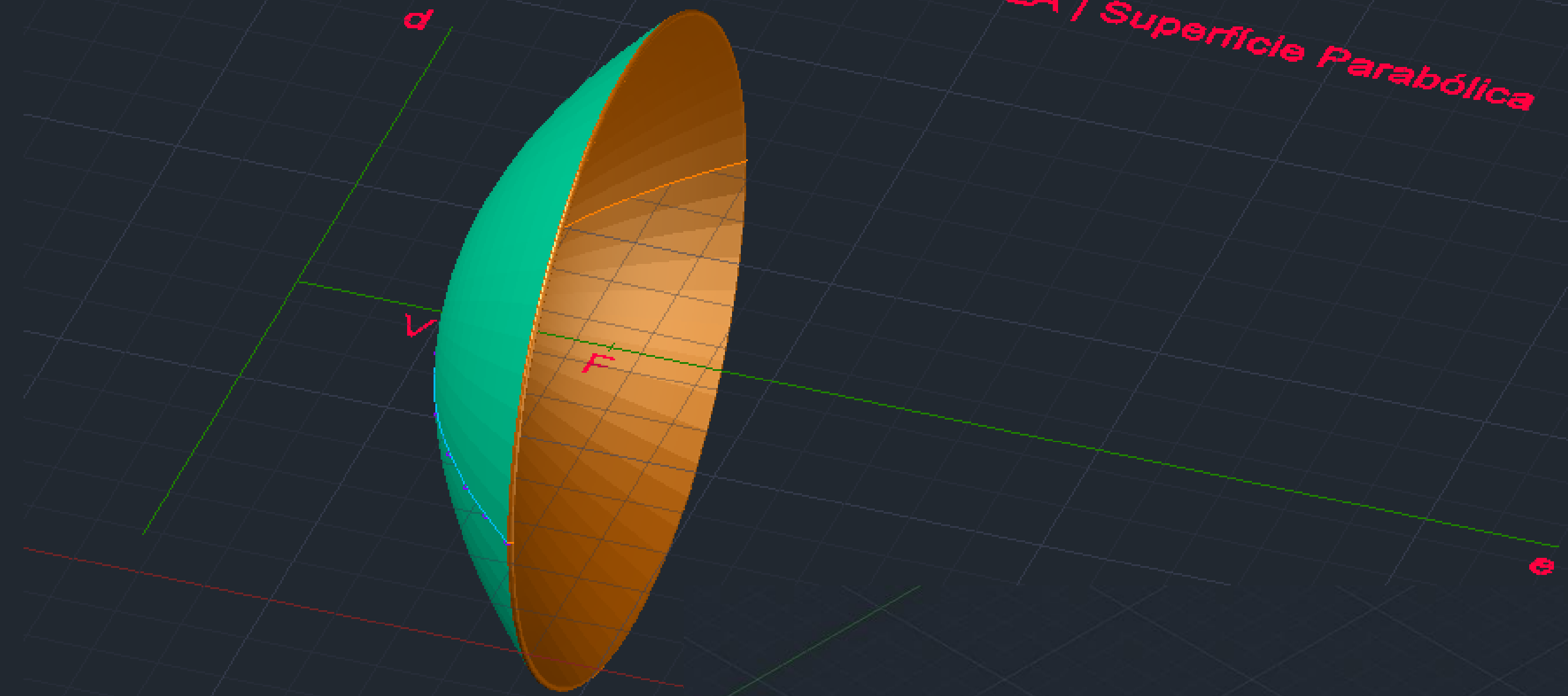
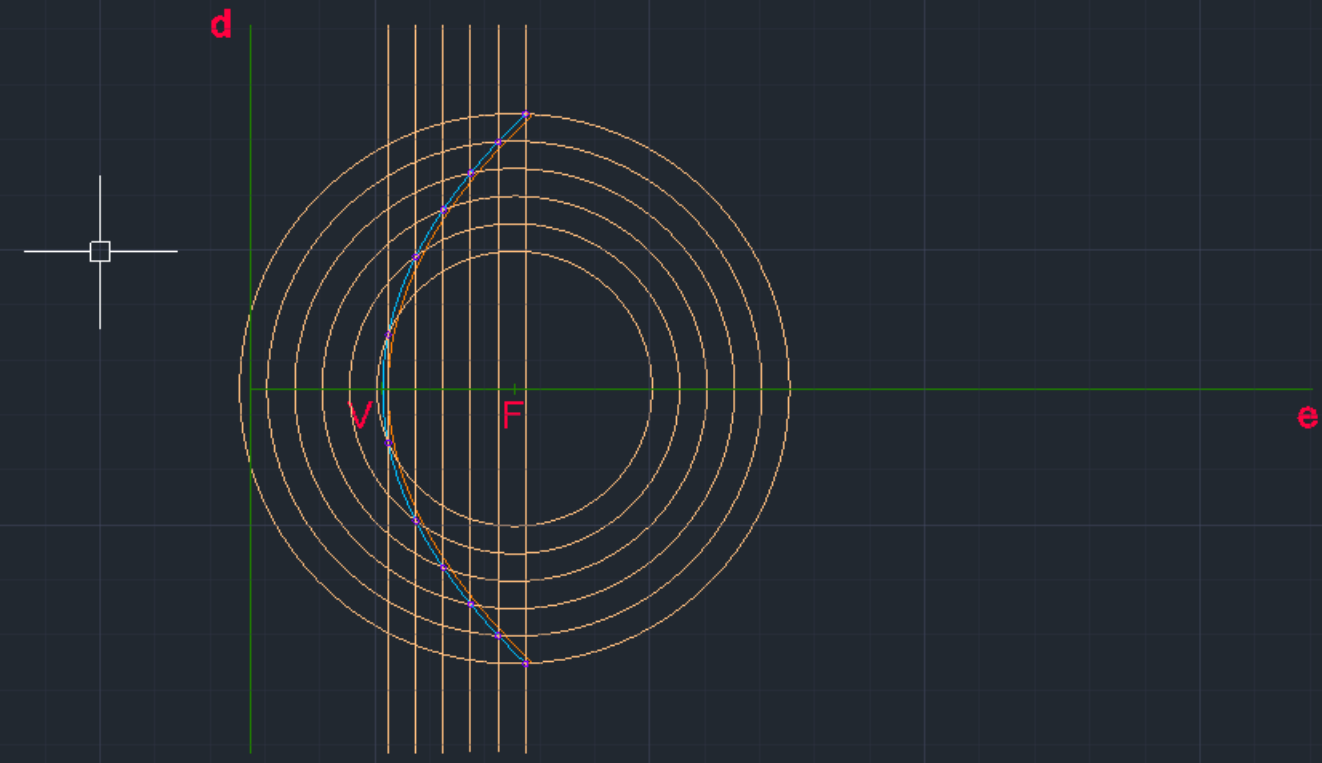

# Exerc. 1.1 - Superfície Parabólica

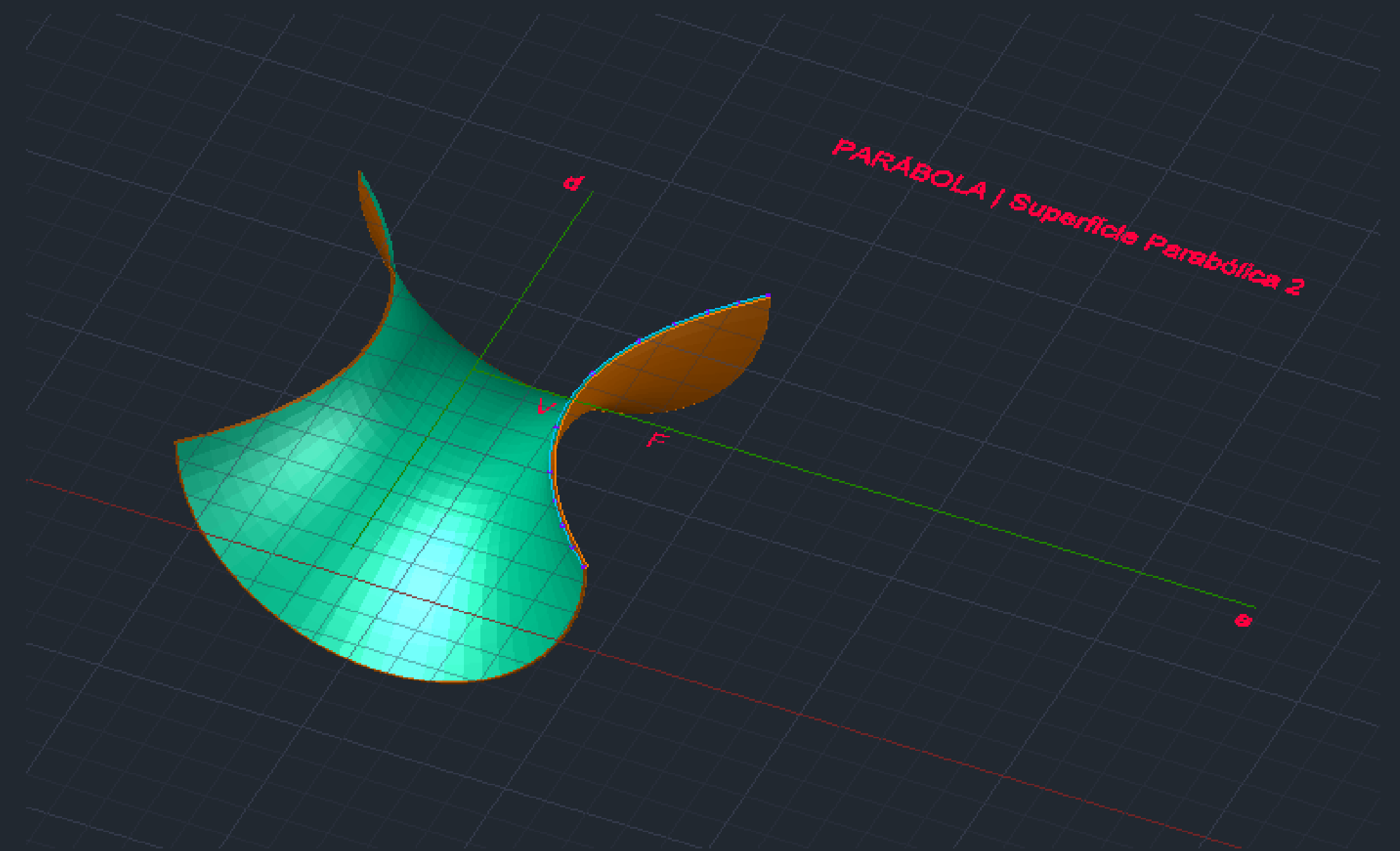
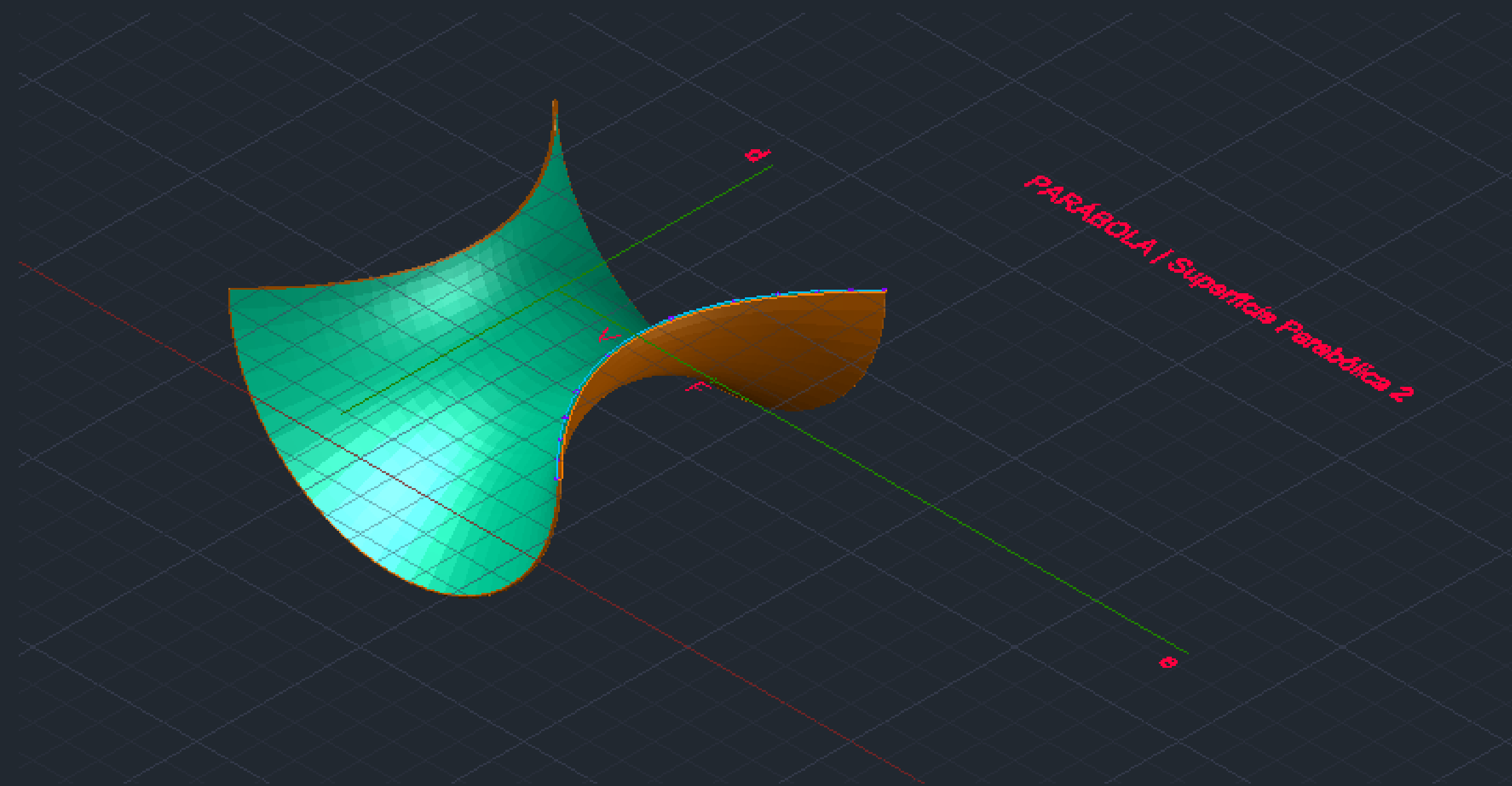

# Exerc. 1.2 - Superfície Parabólica

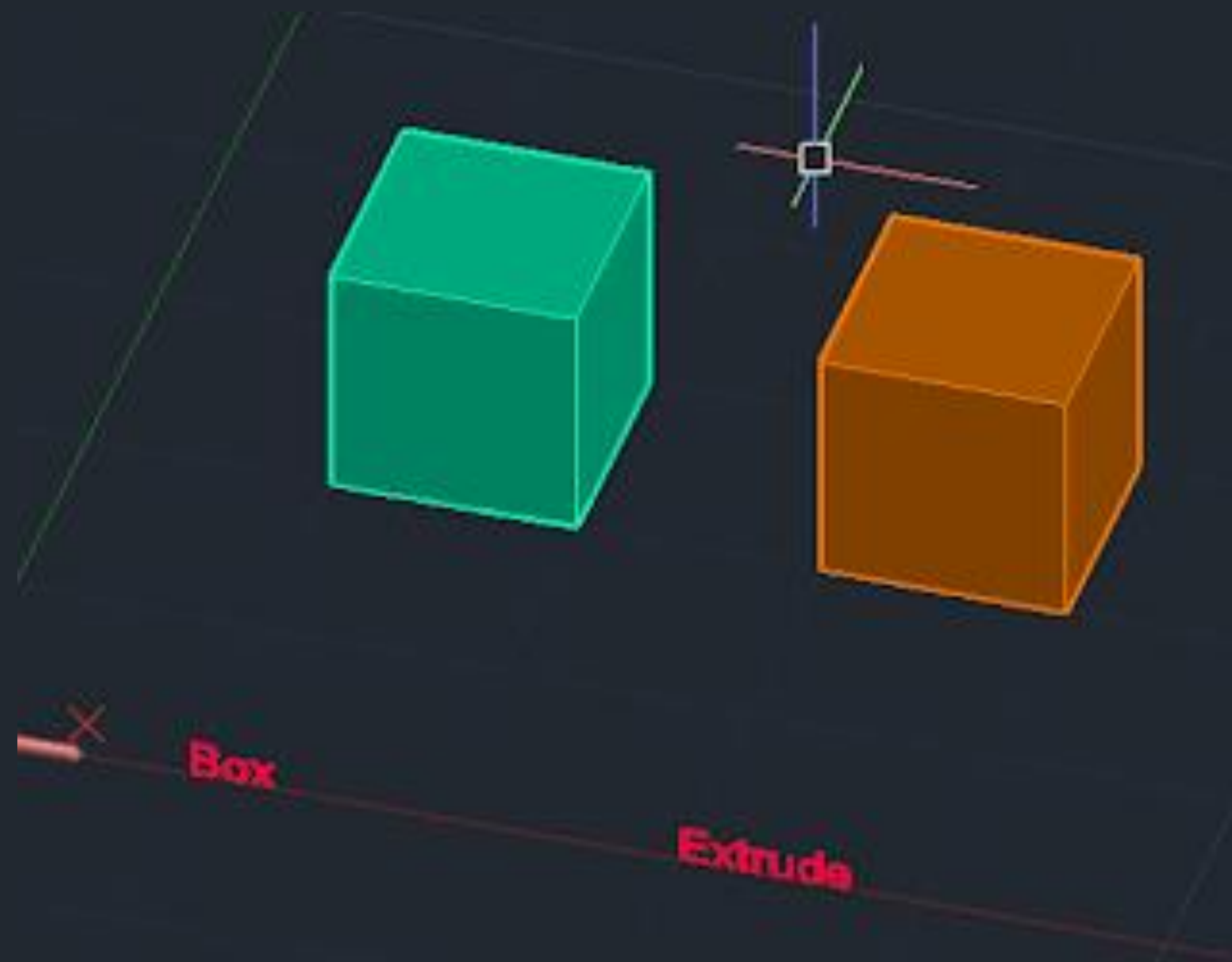

## Exerc. 2 – Sólidos Geométricos

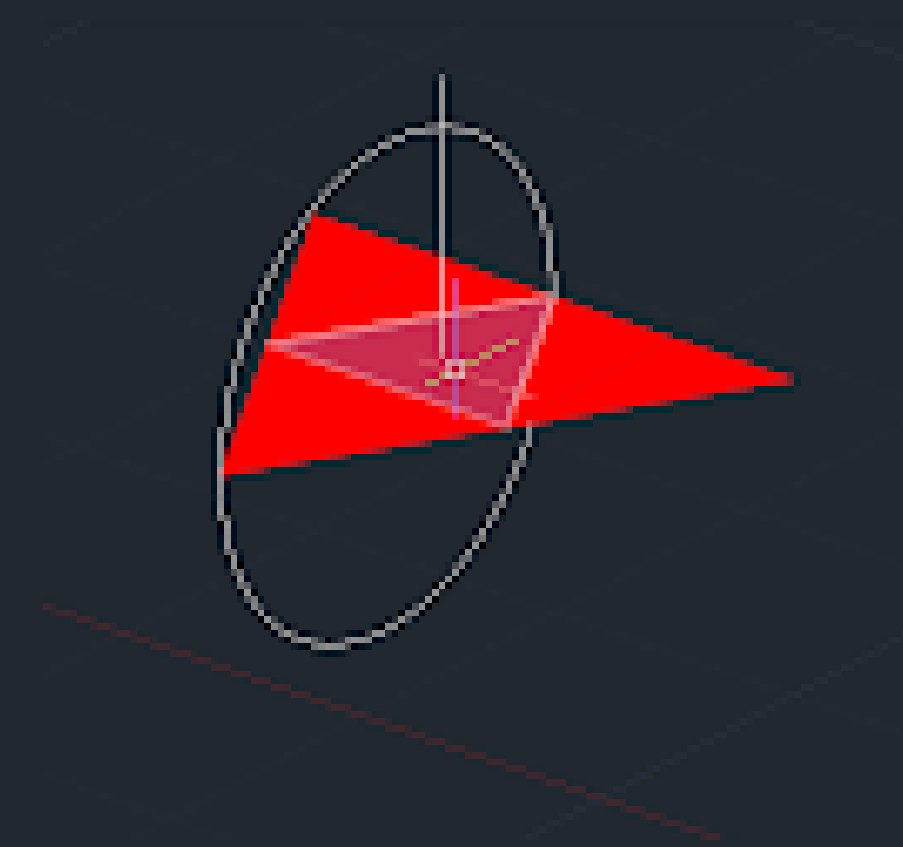

Tetraedro

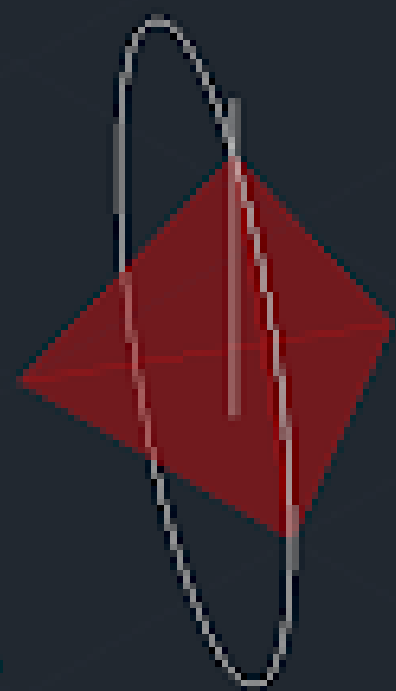

Tetraedro

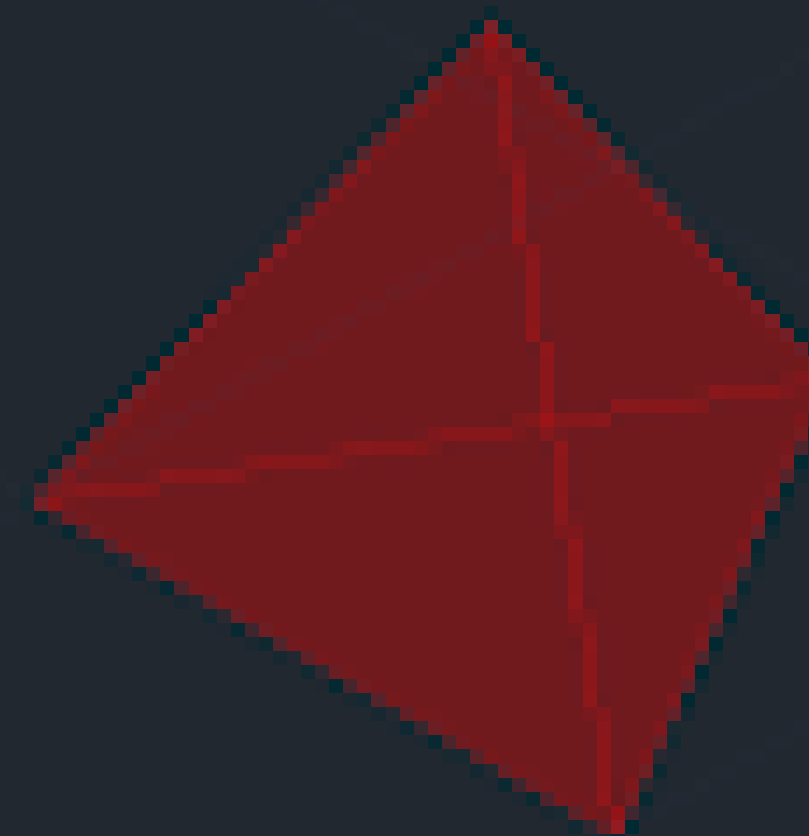

# Exerc. 2 – Sólidos Geométricos

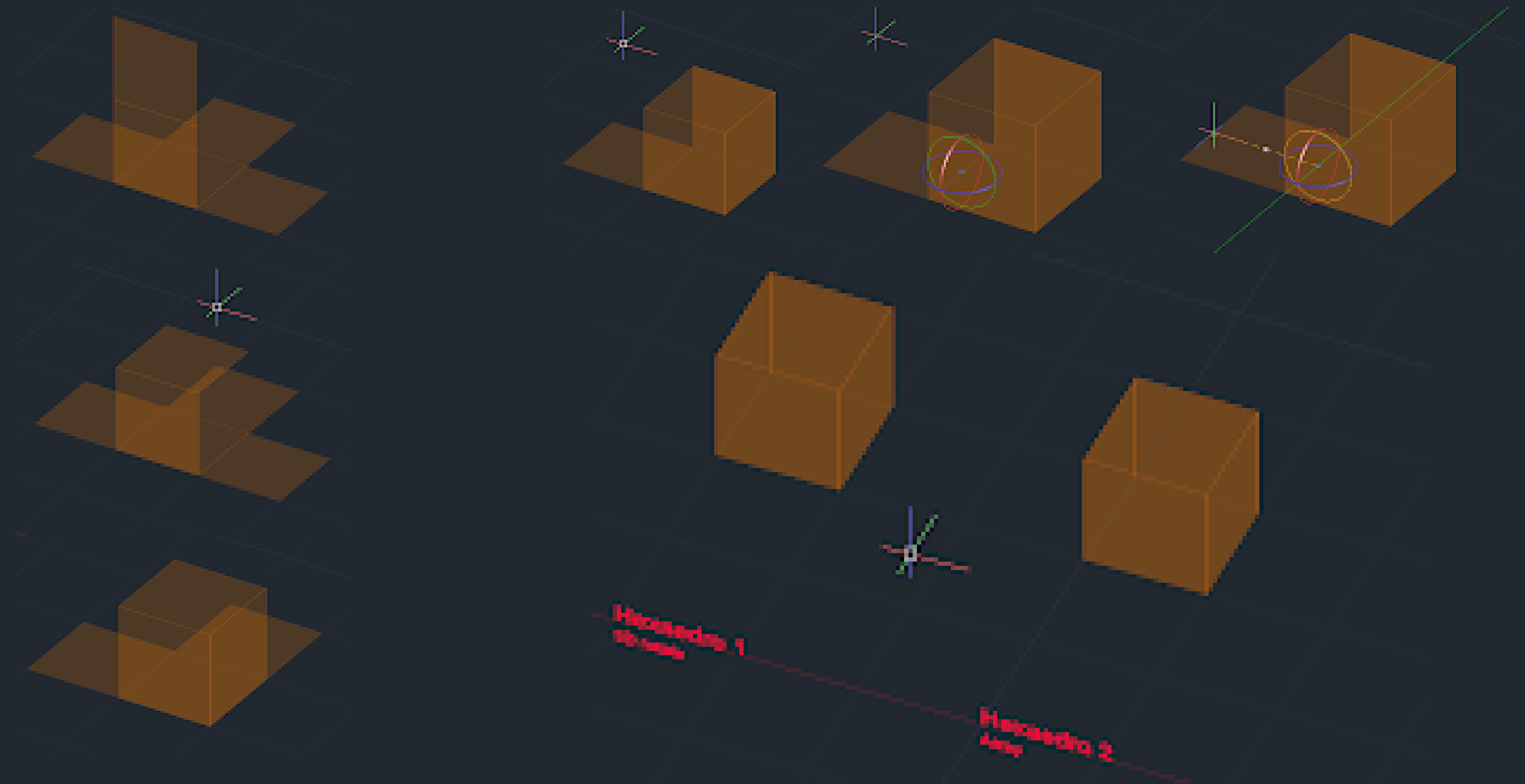

# Exerc. 2 – Sólidos Geométricos



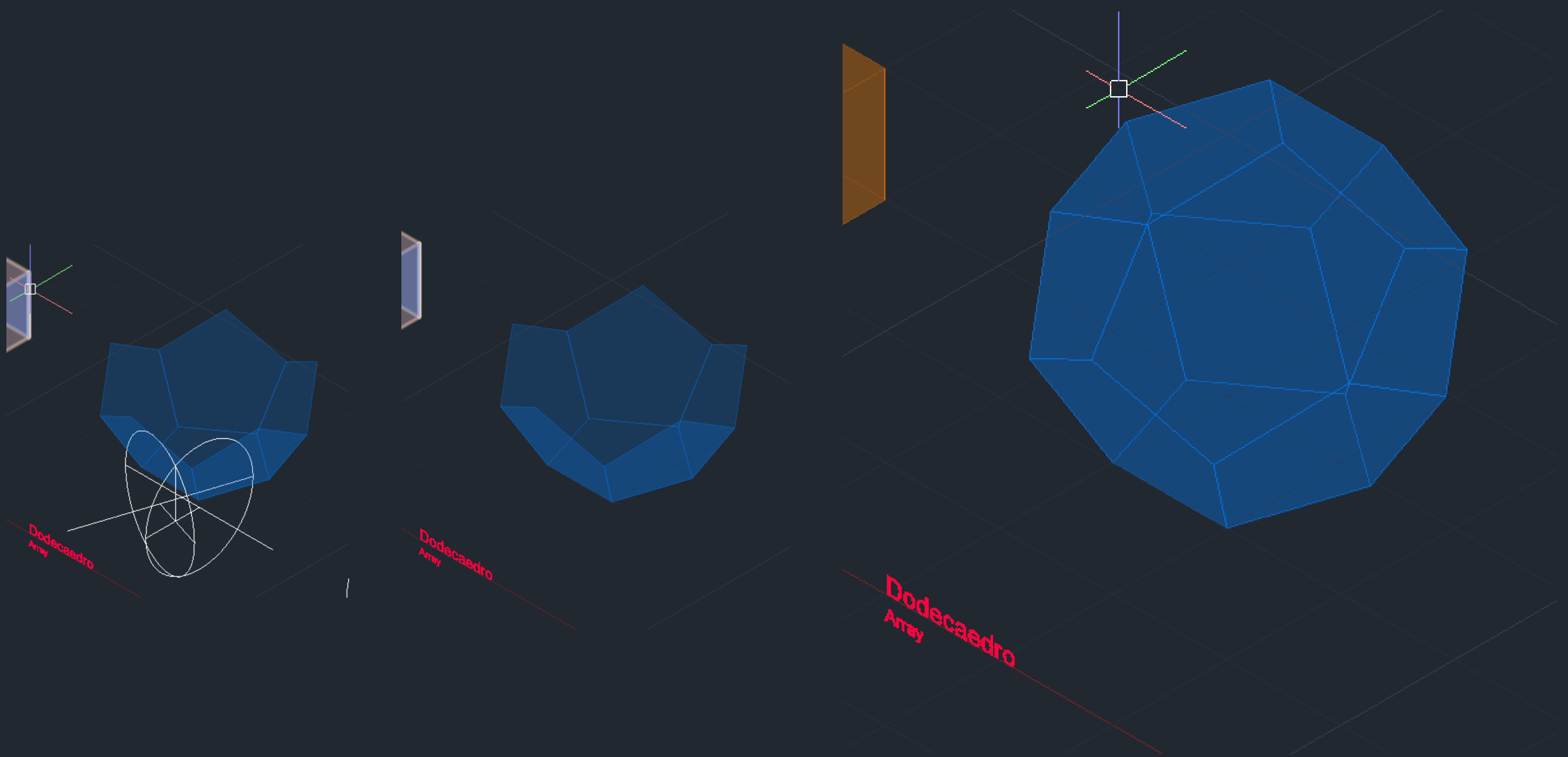

# Exerc. 2 – Sólidos Geométricos

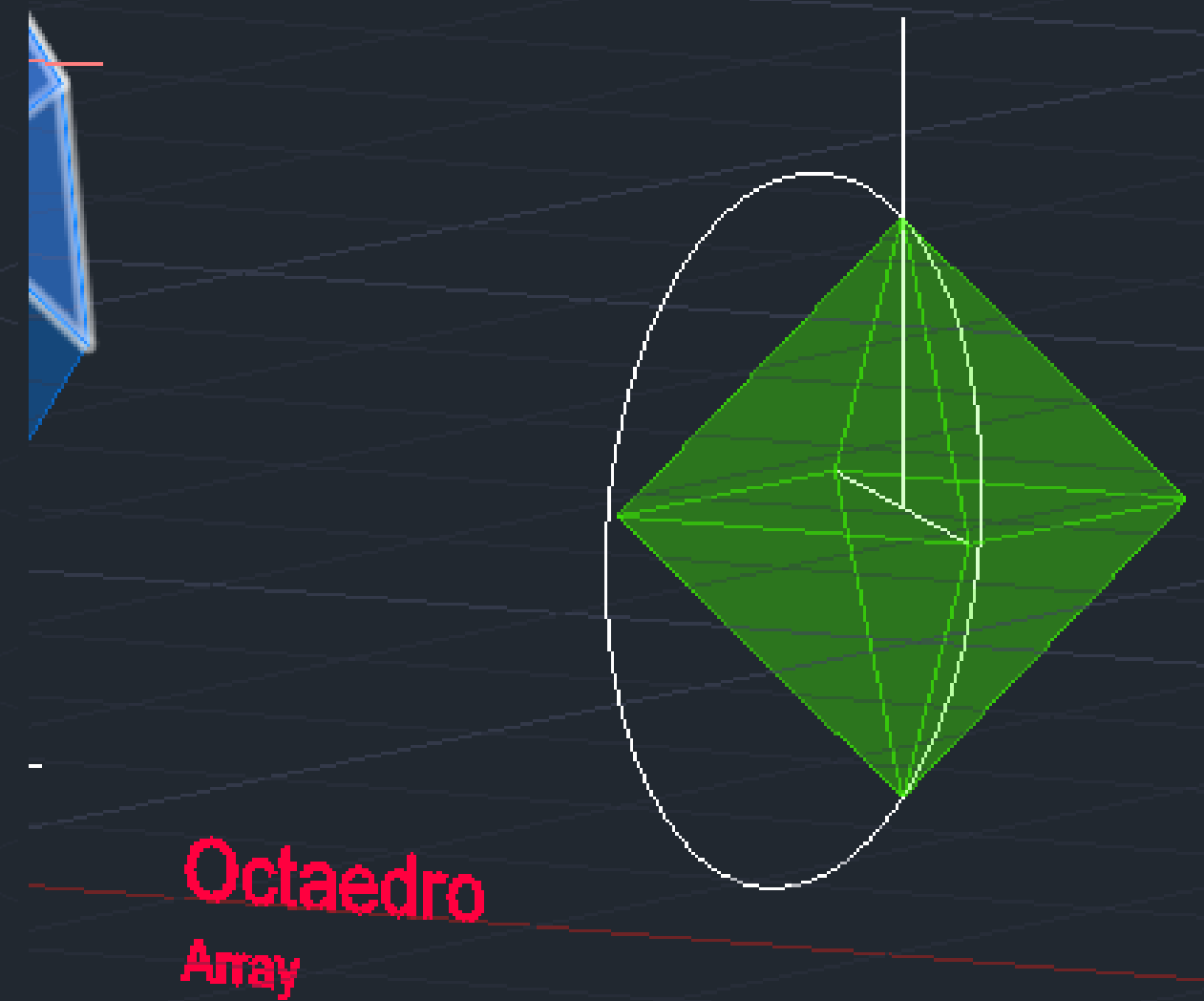
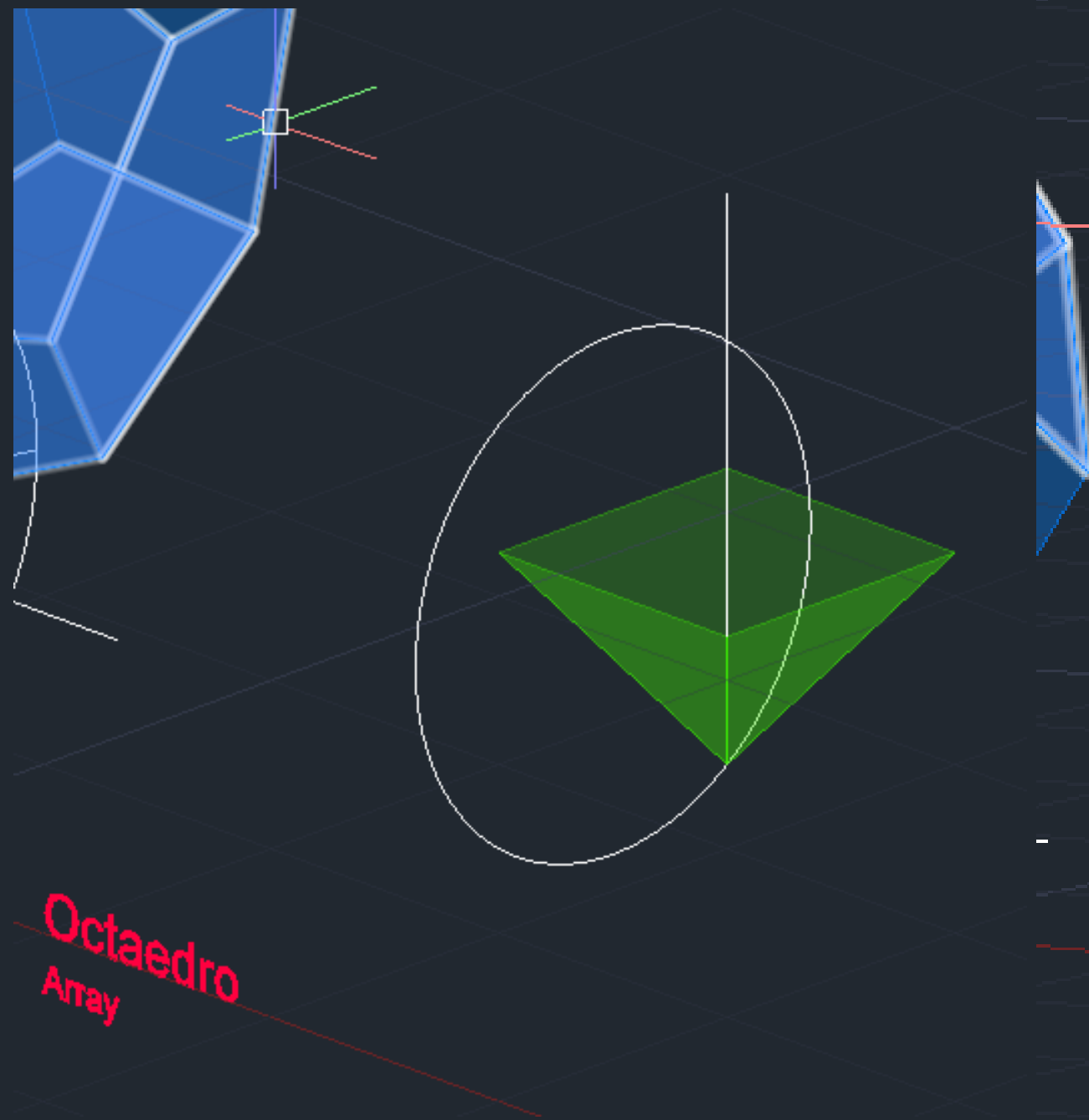

# Exerc. 2 – Sólidos Geométricos

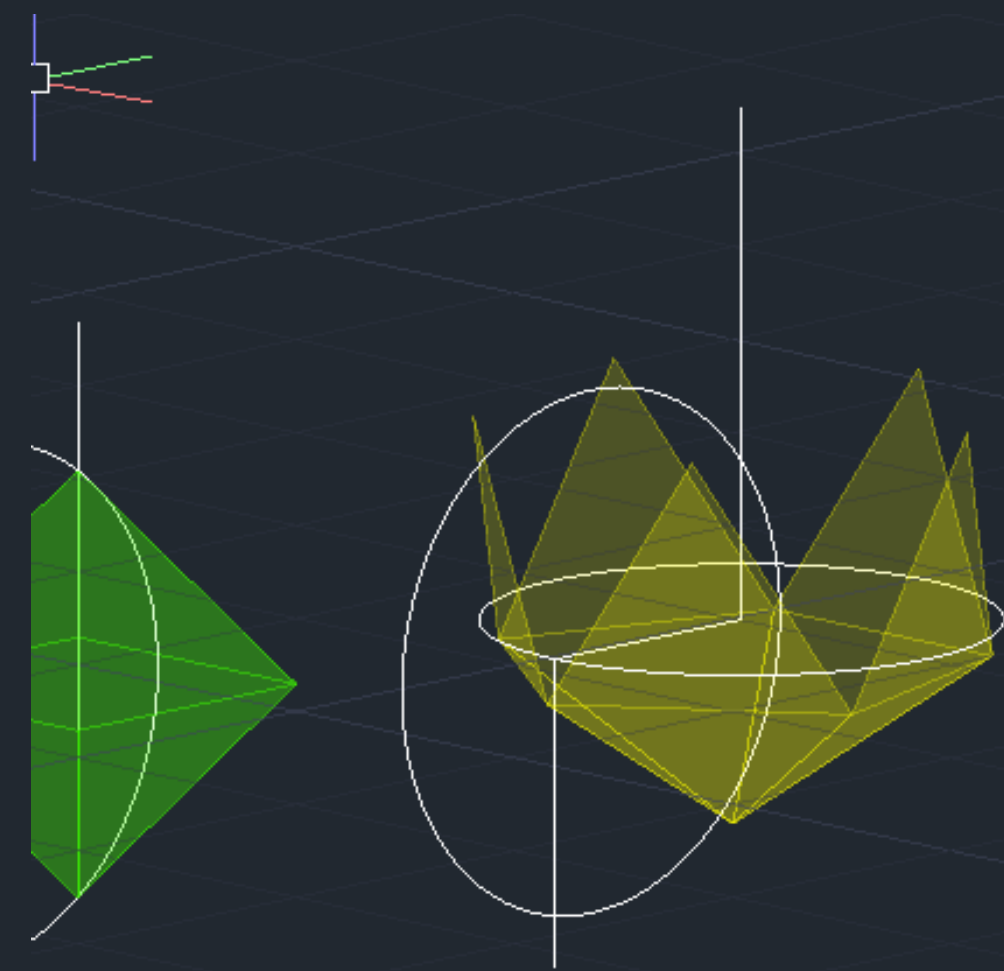

Icosaedro  
Array

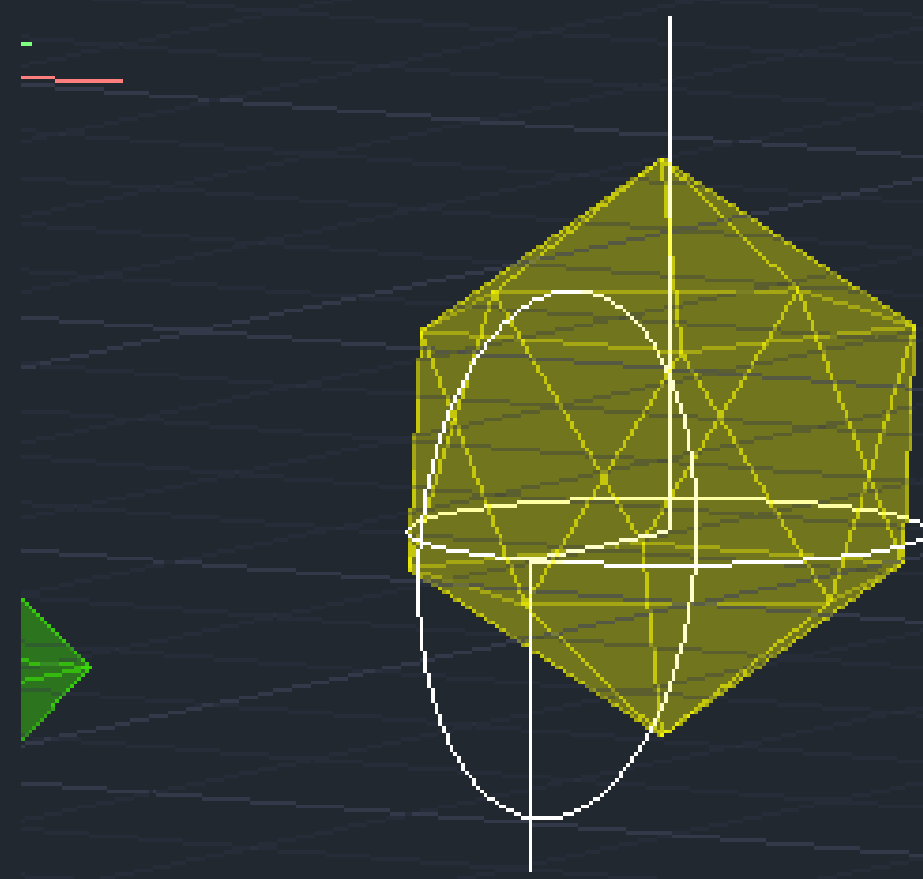

Icosaedro  
Array

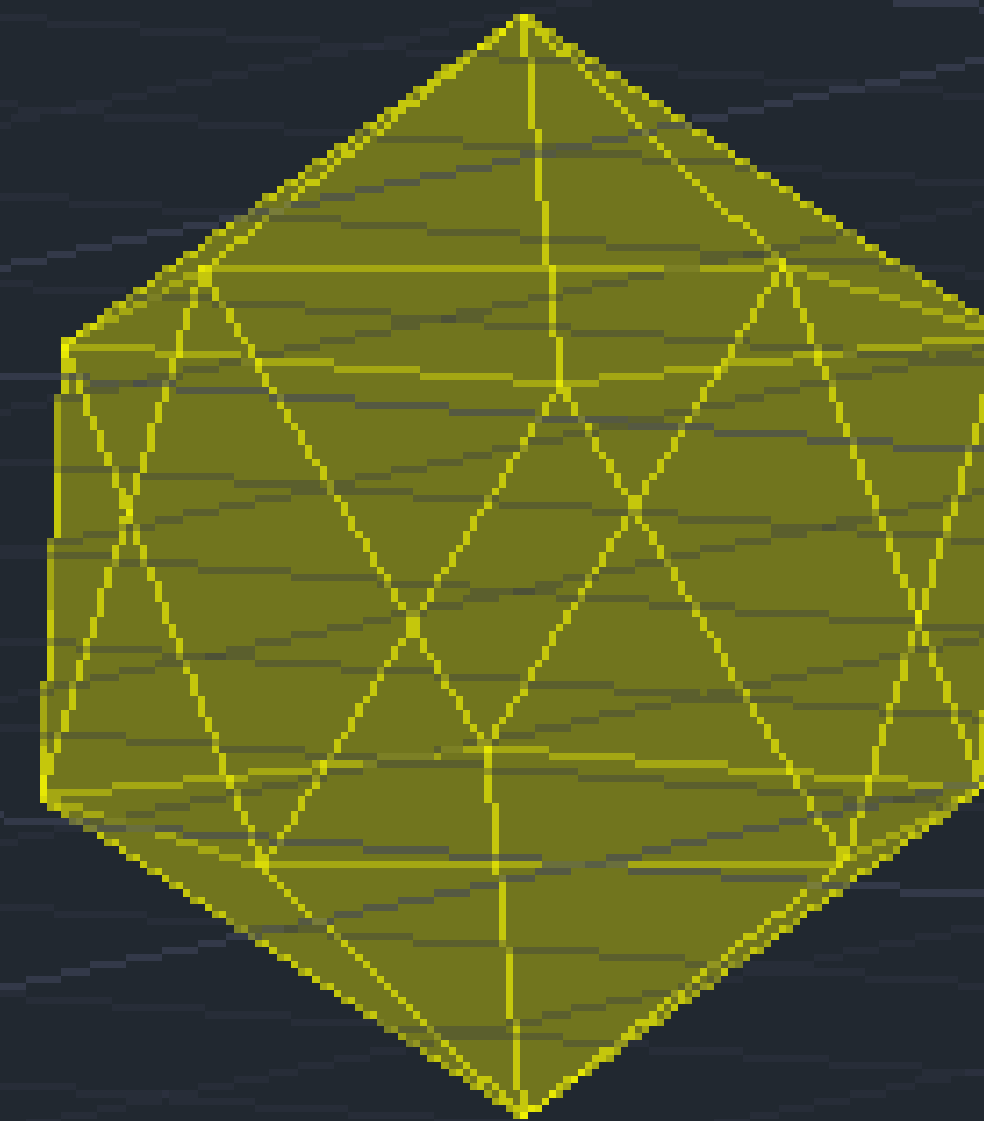

Icosaedro  
Array

# Exerc. 2 – Sólidos Geométricos

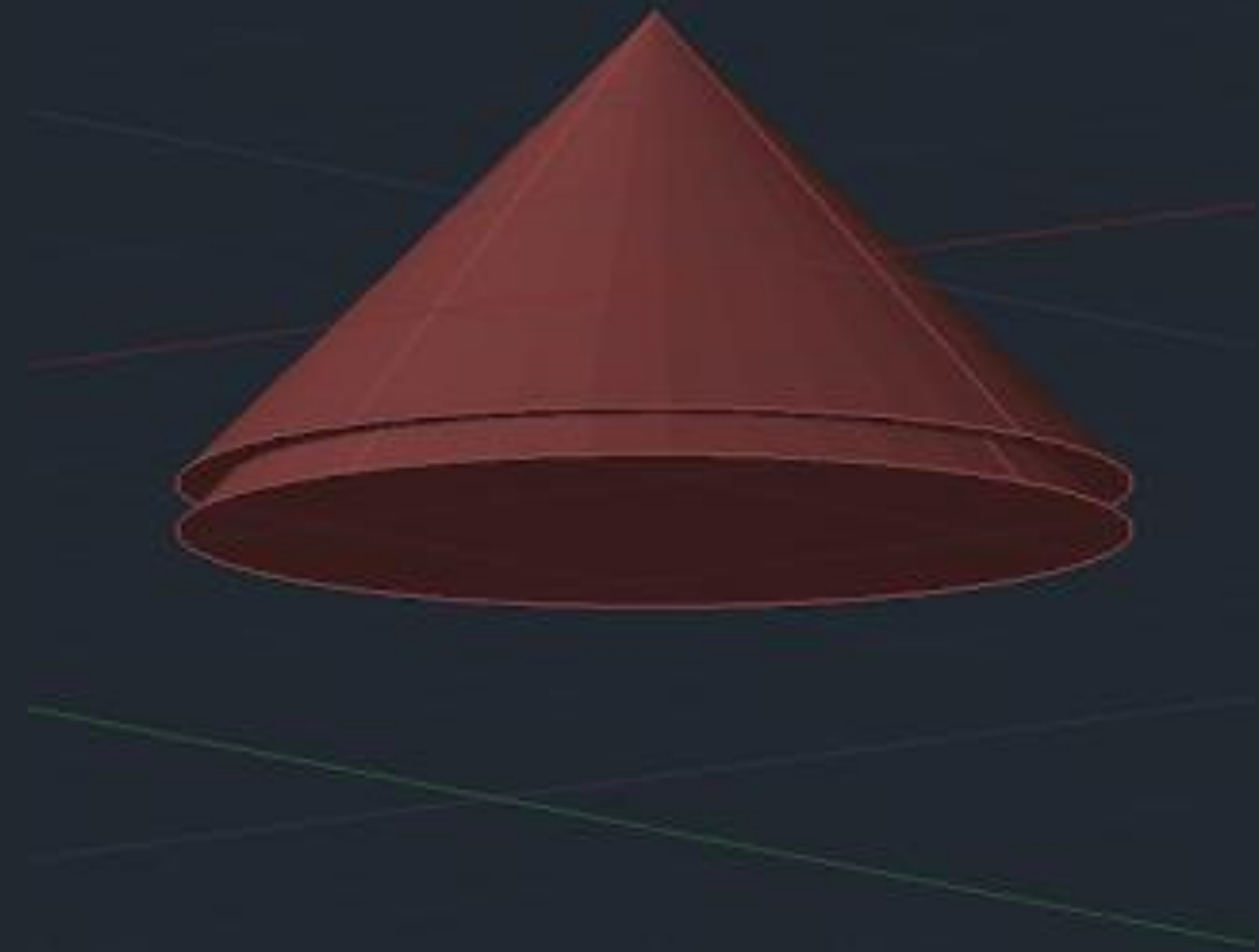

Exerc. 3 – Secções em um Cone

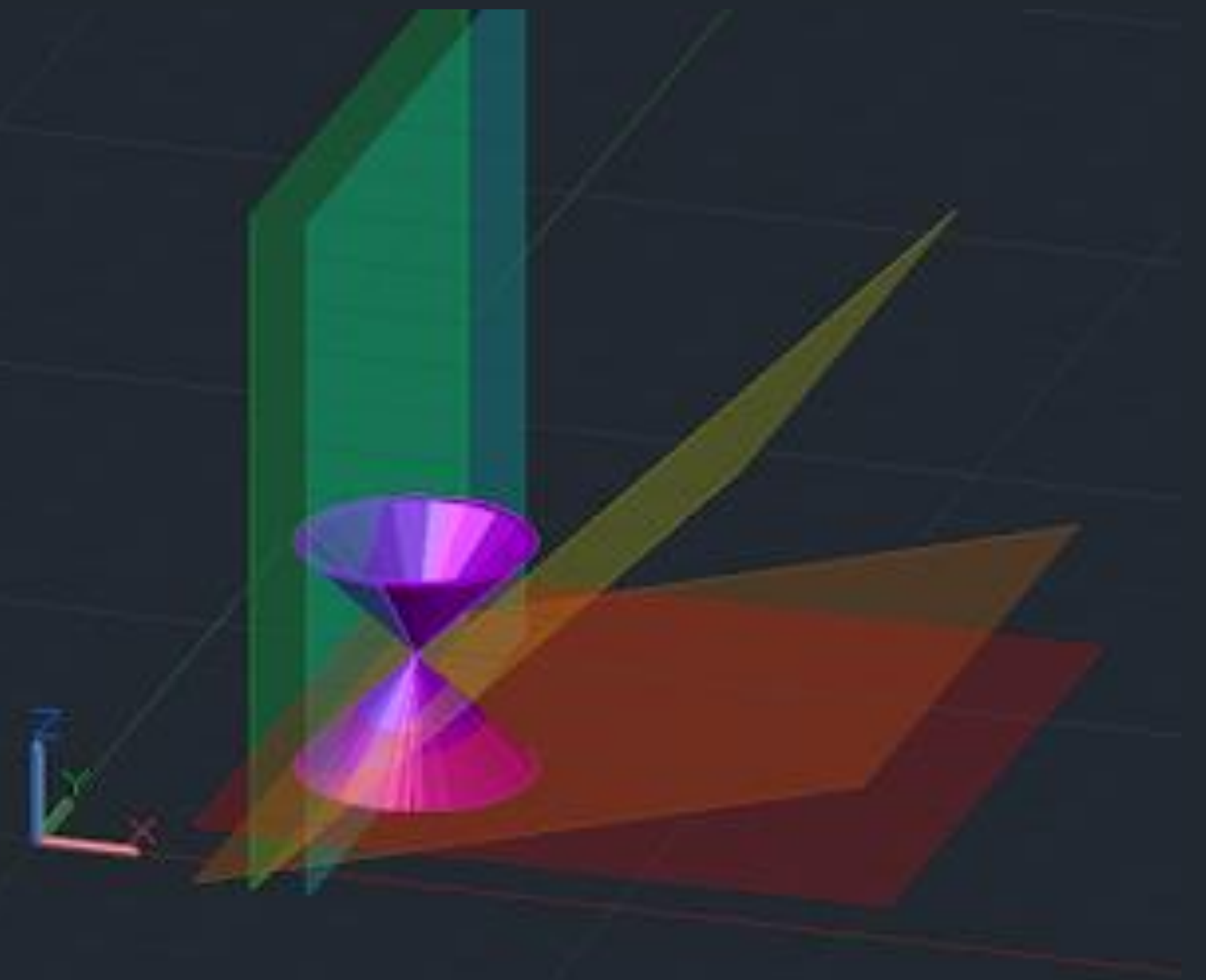
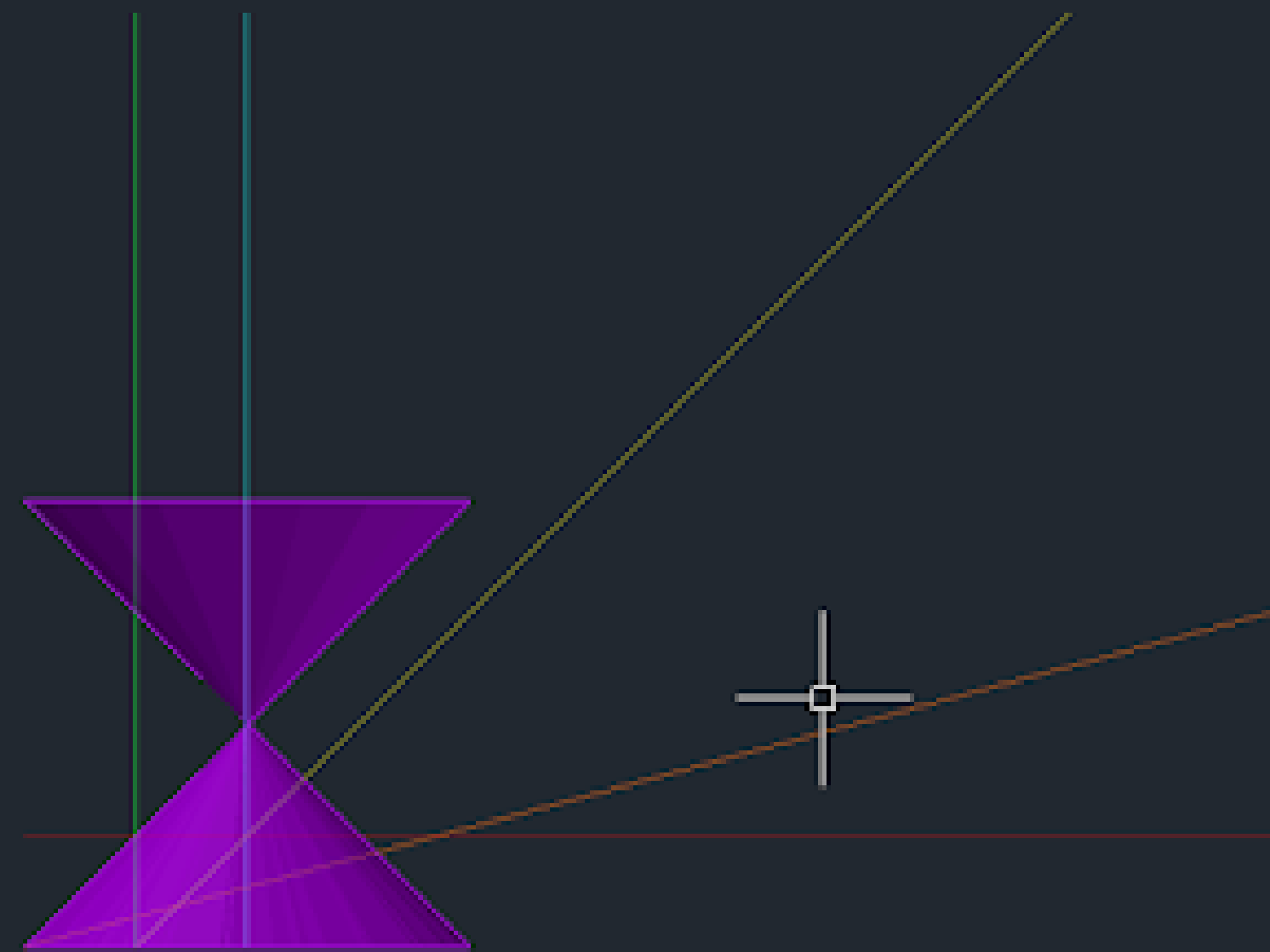
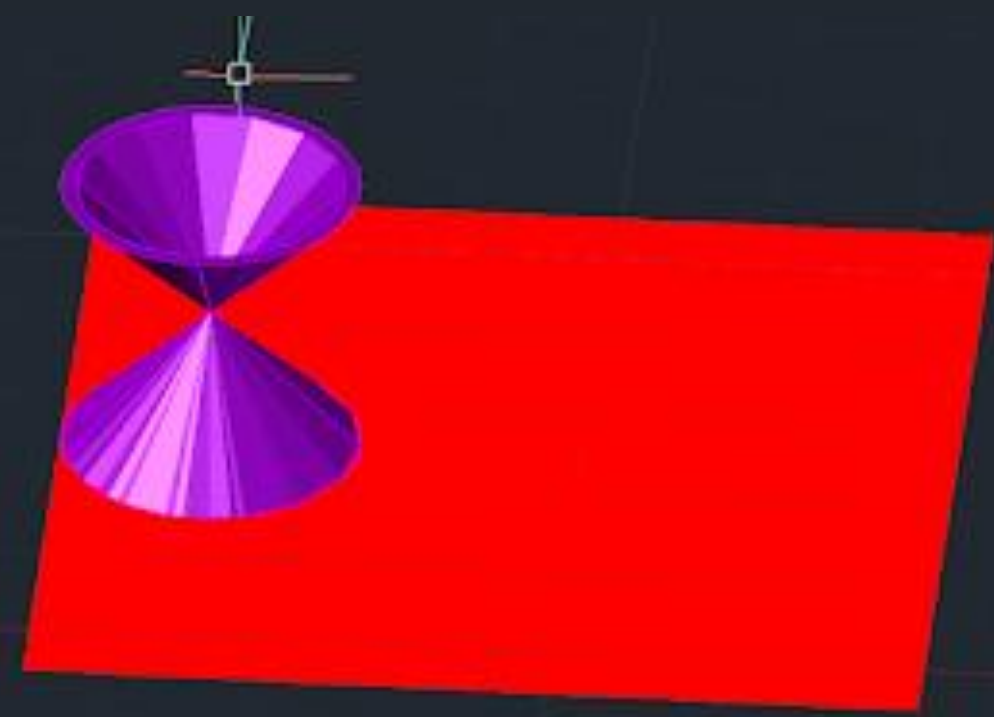

Exerc. 3 – Secções em um Cone

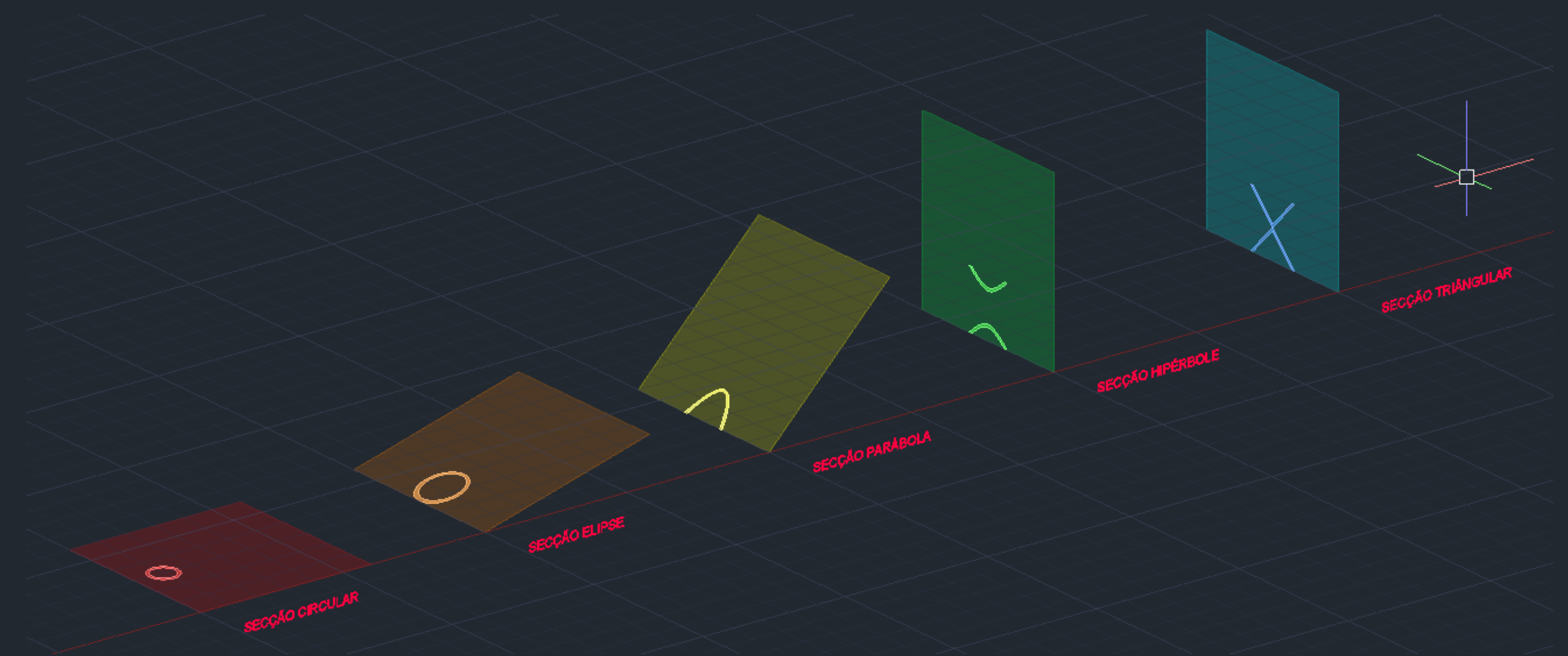

# Exerc. 3 – Secções em um Cone

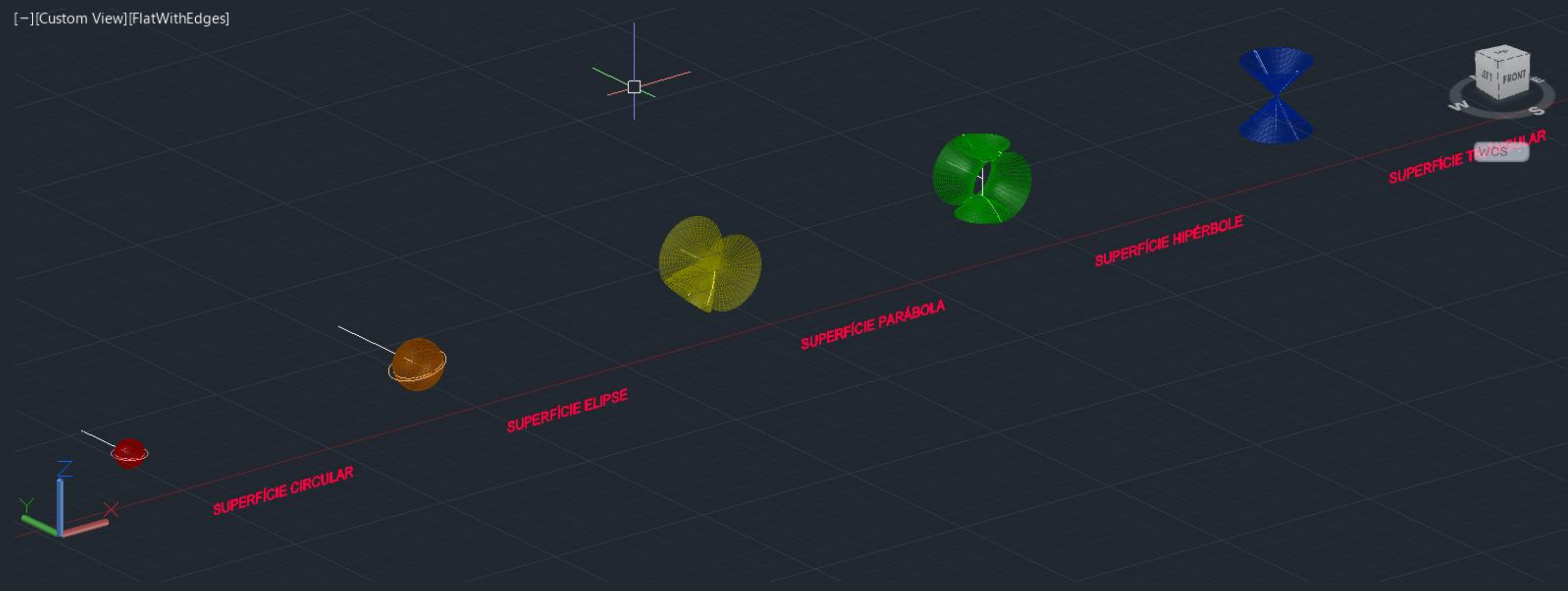

# Exerc. 4 – XADREZ

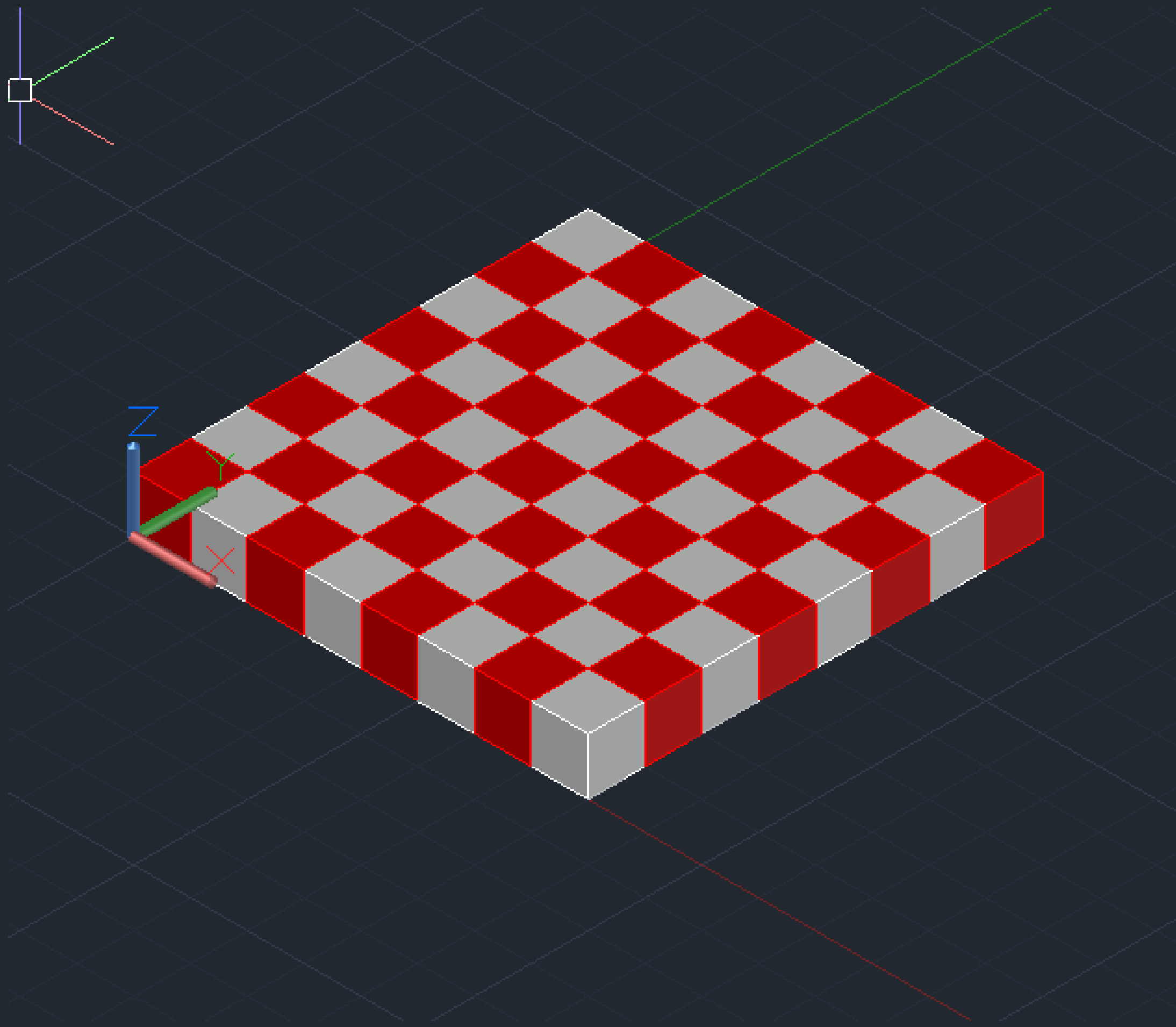

```
(defun c:Xad ()  
  
  (command "box" "0,0,0" "10,10,10")  
  (command "copy" "last" "" "0,0" "10,10")  
  (command "mirror" "all" "" "10,0" "10,10" "")  
  (command "chprop" "previous" "" "c" "1" "")  
  (command "array" "all" "" "R" "4" "4" "20" "20" "")  
)
```

## Exerc. 3 – Comando XAD



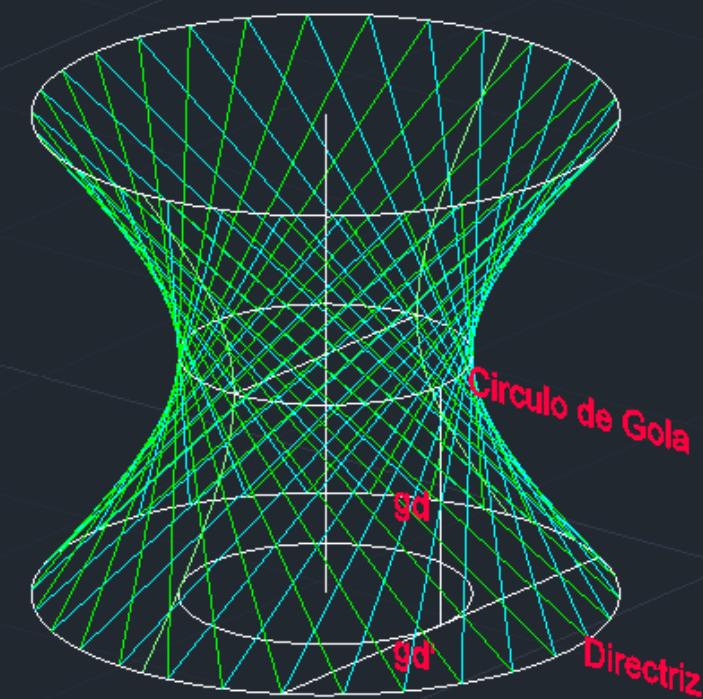
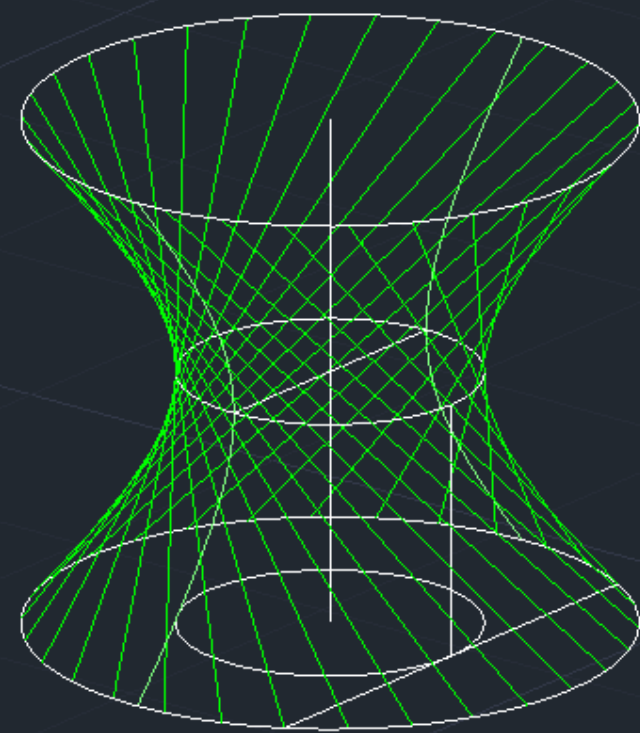
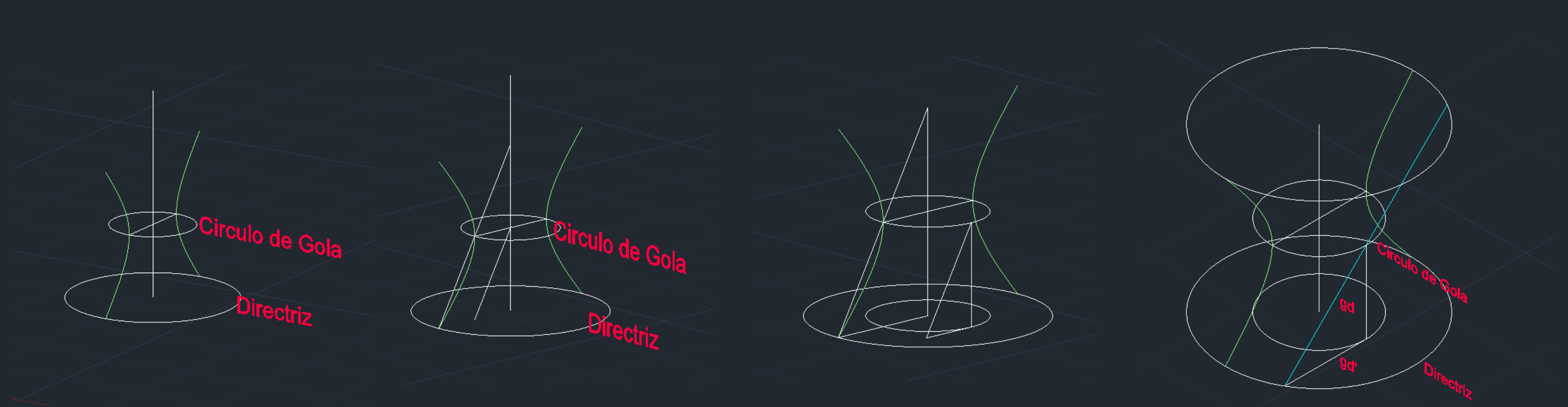
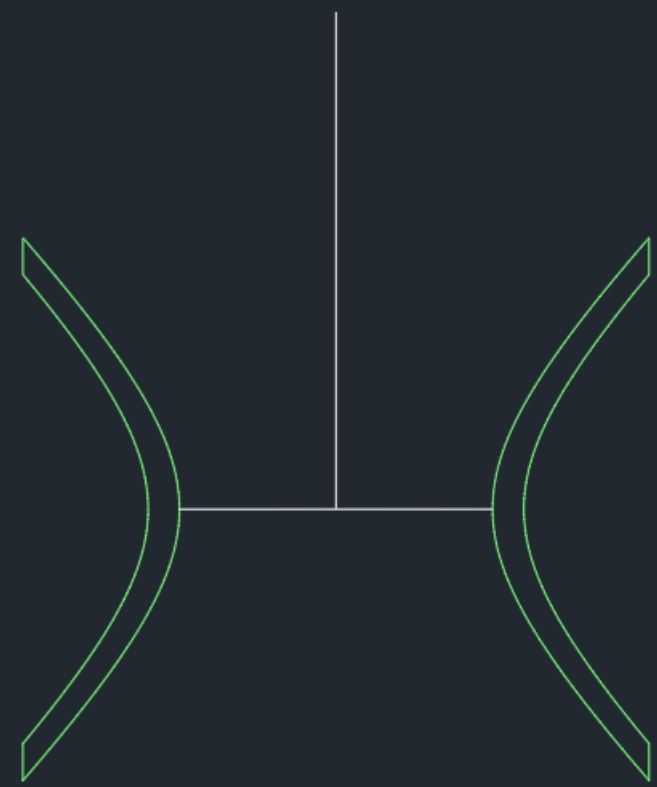

# Exerc. 5 – Hiperboloide

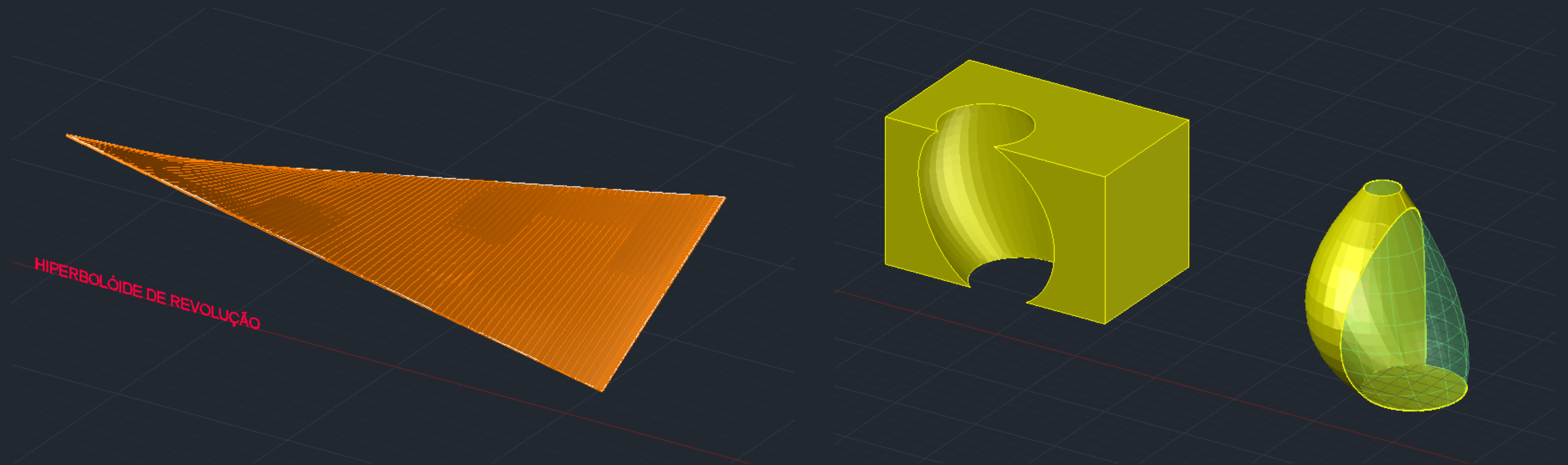

# Exerc. 6 – Superfícies curvas

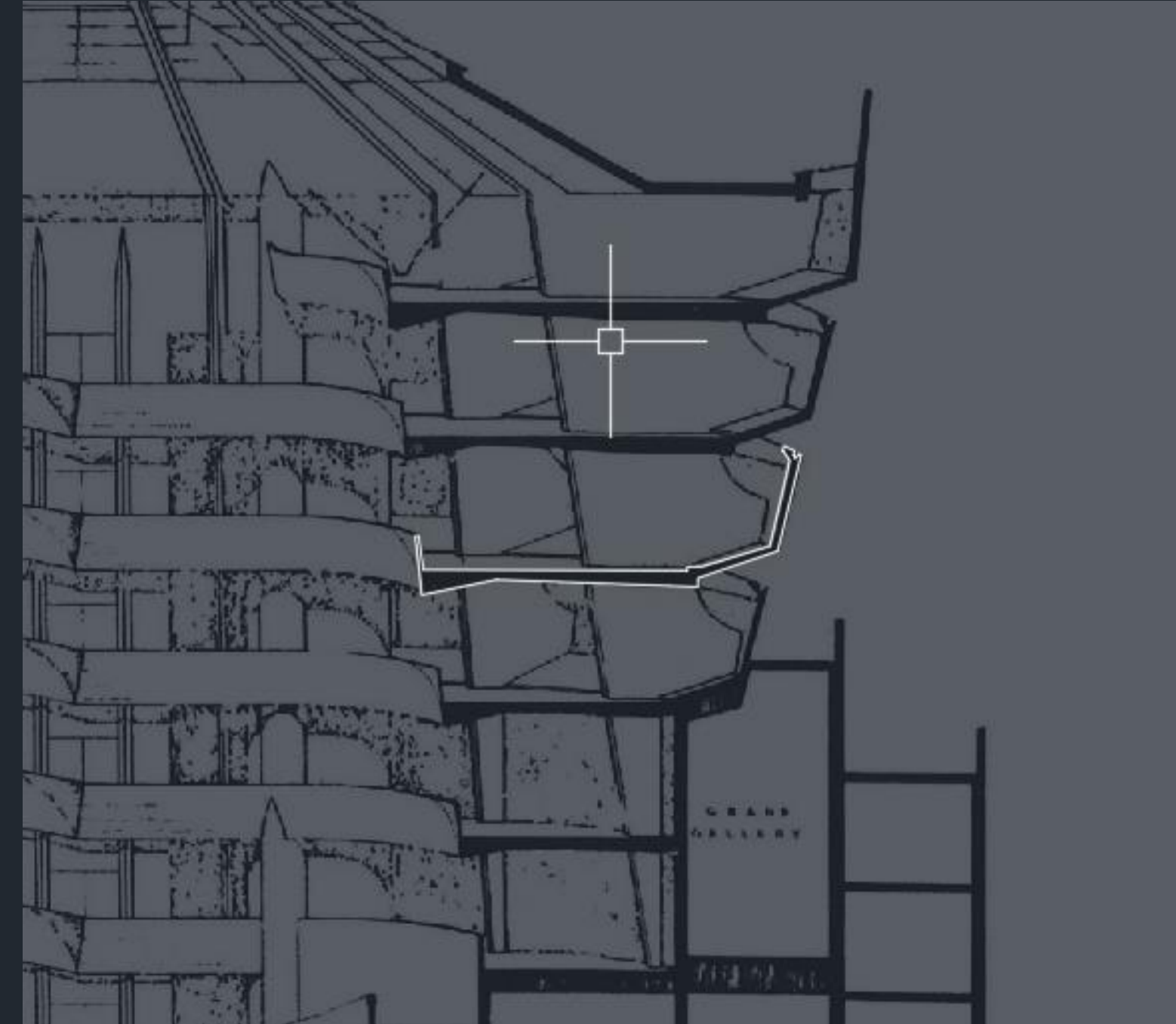

Exerc. 7 – Hélix

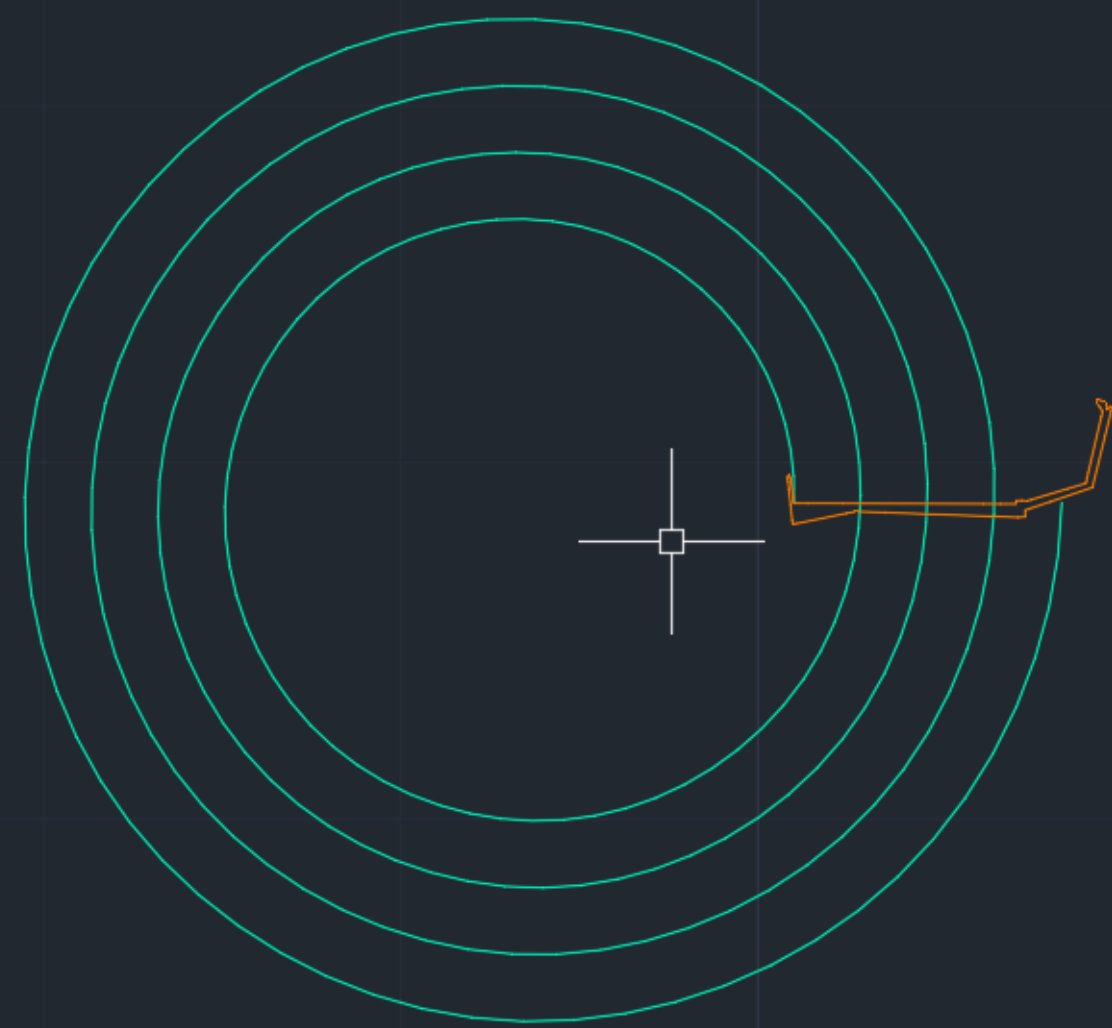

Exerc. 7 – Hélix

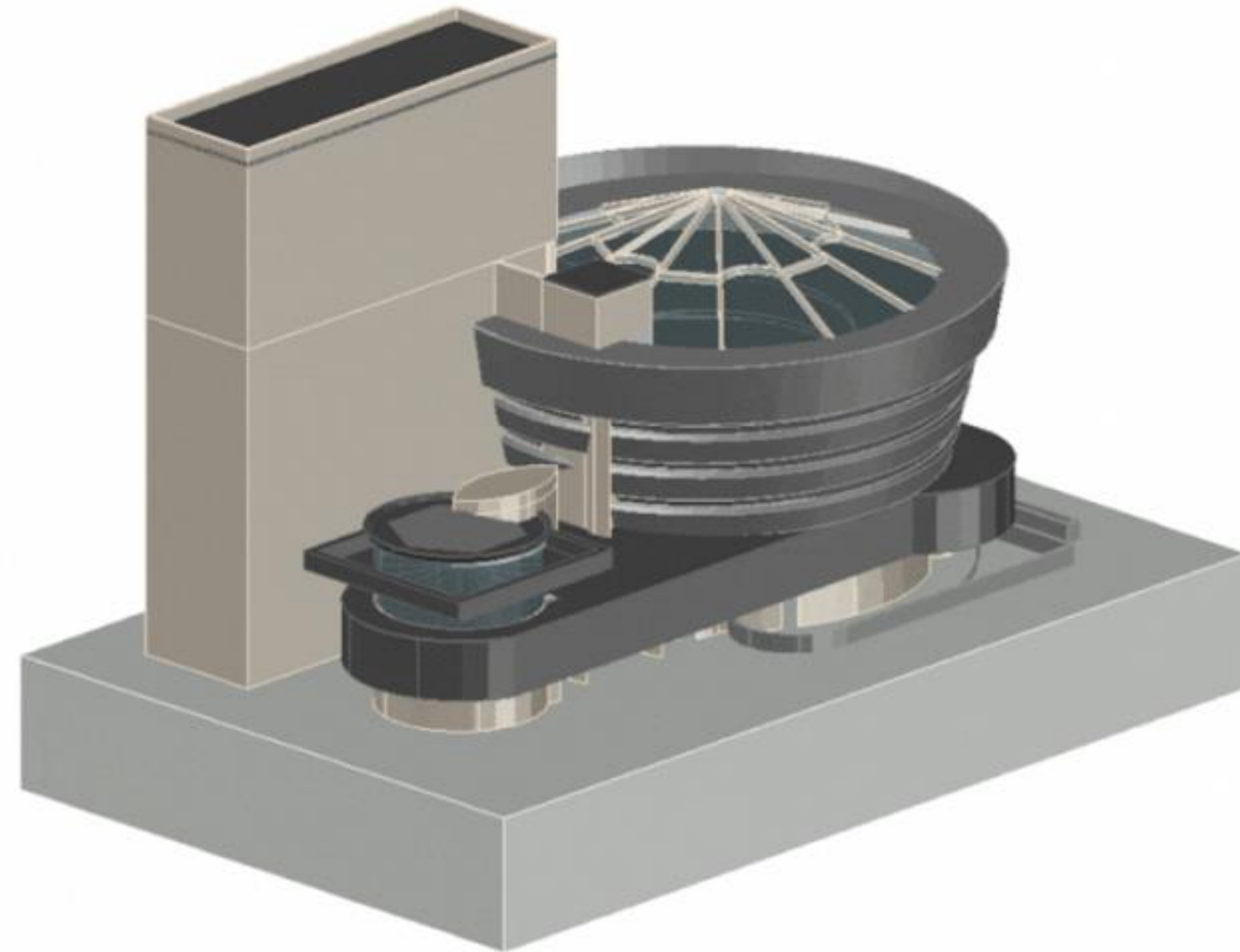

Exerc. 8 – Guggenheim NY

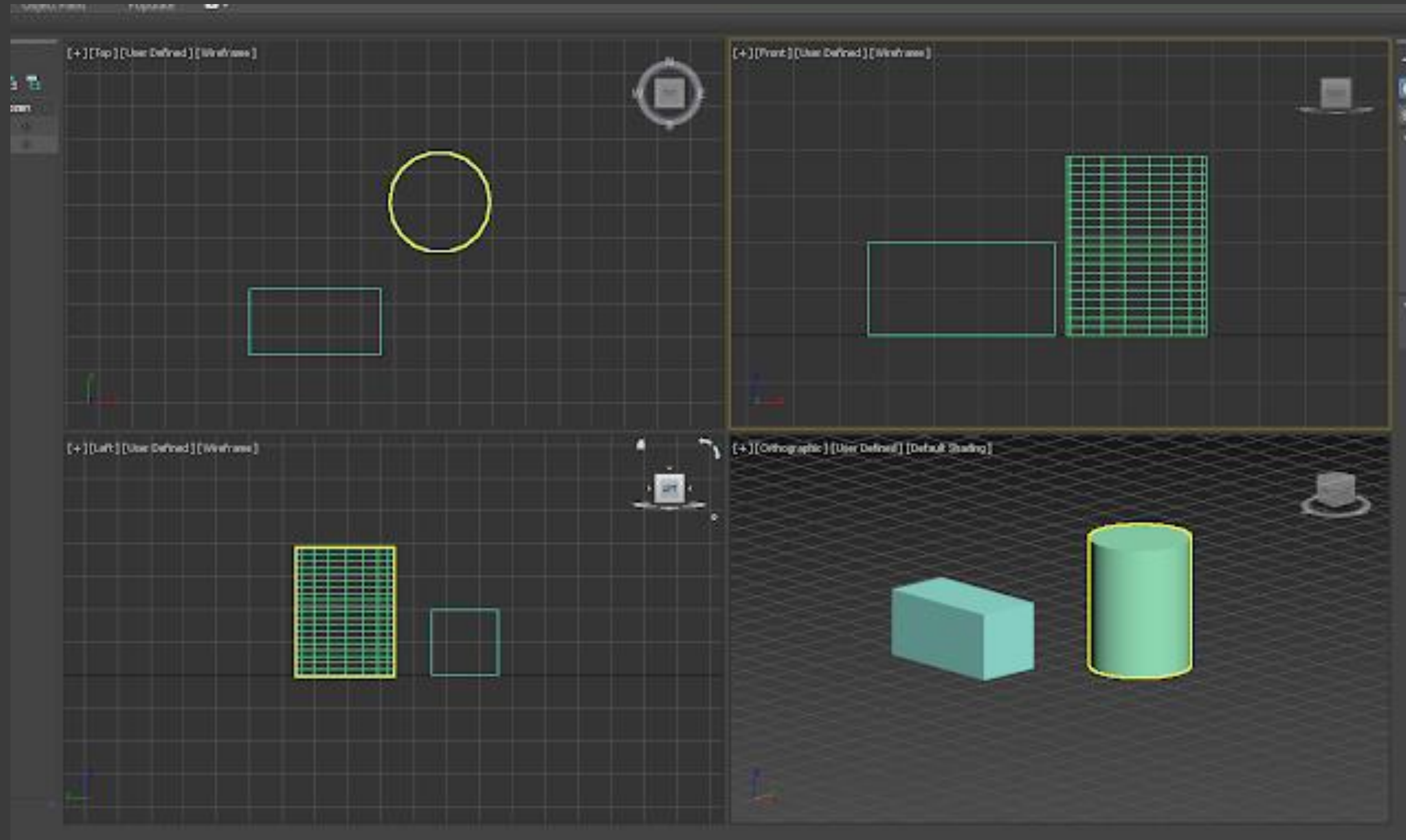

# Exerc. 9 – 3D MAX - Introdução

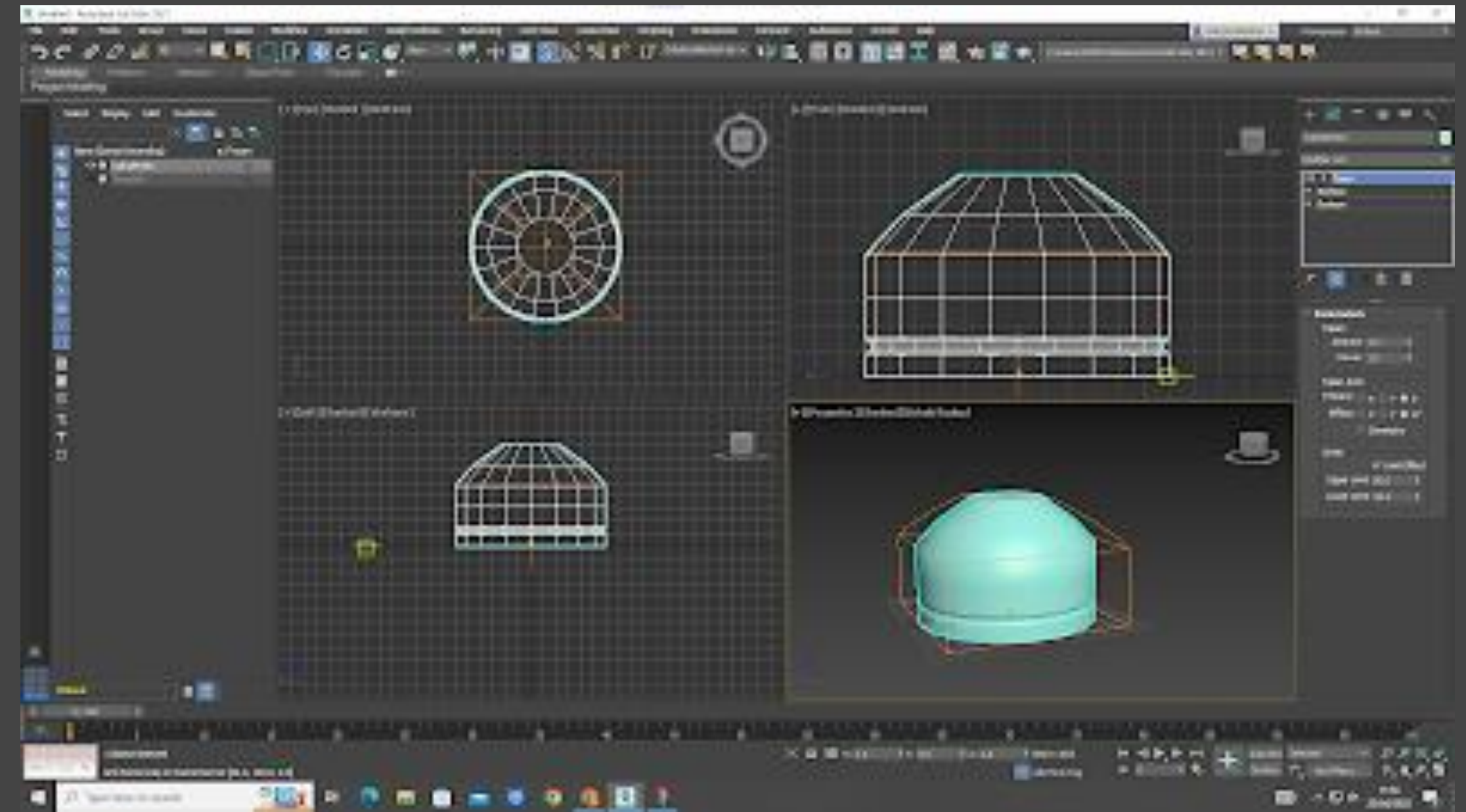
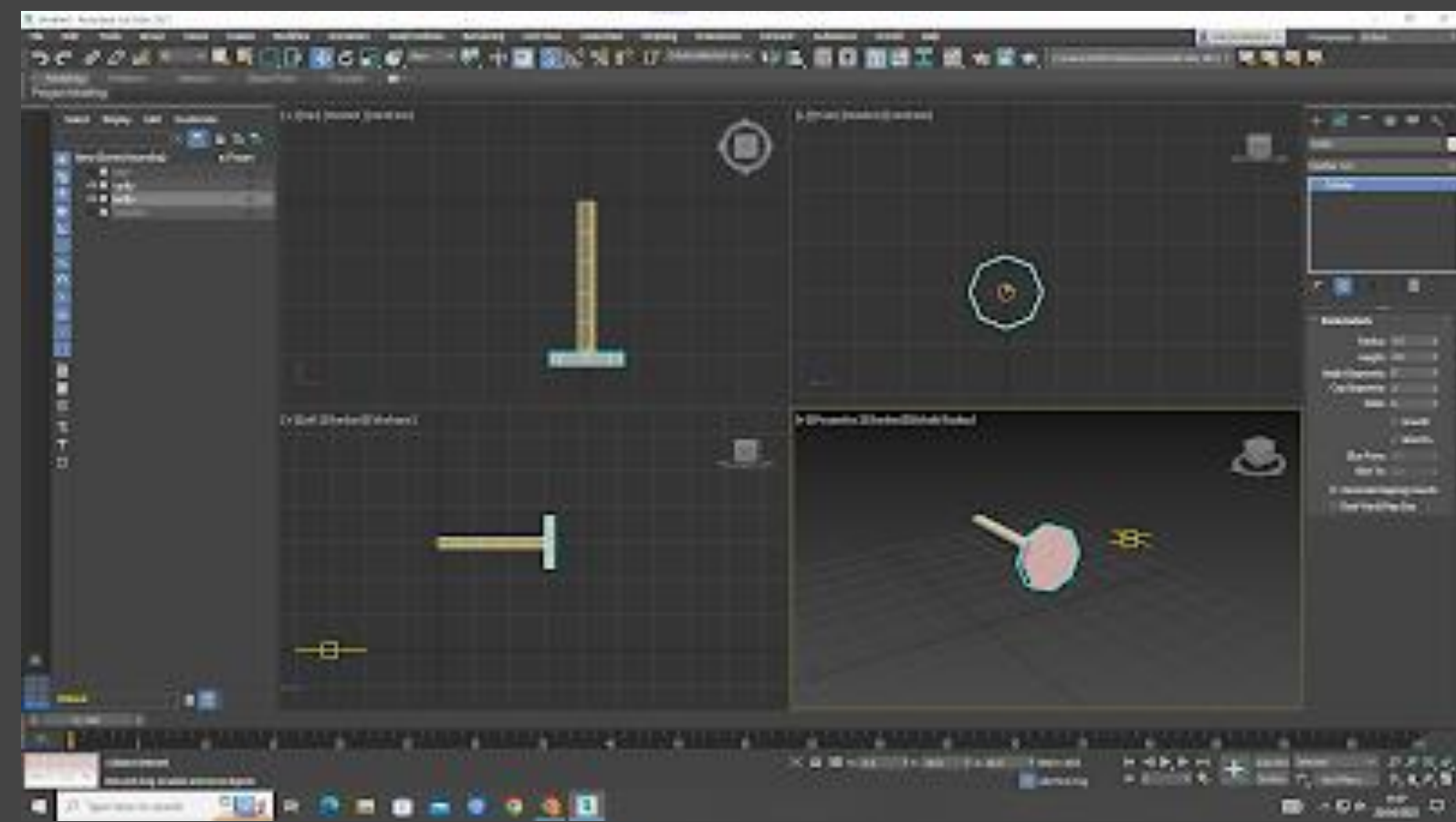
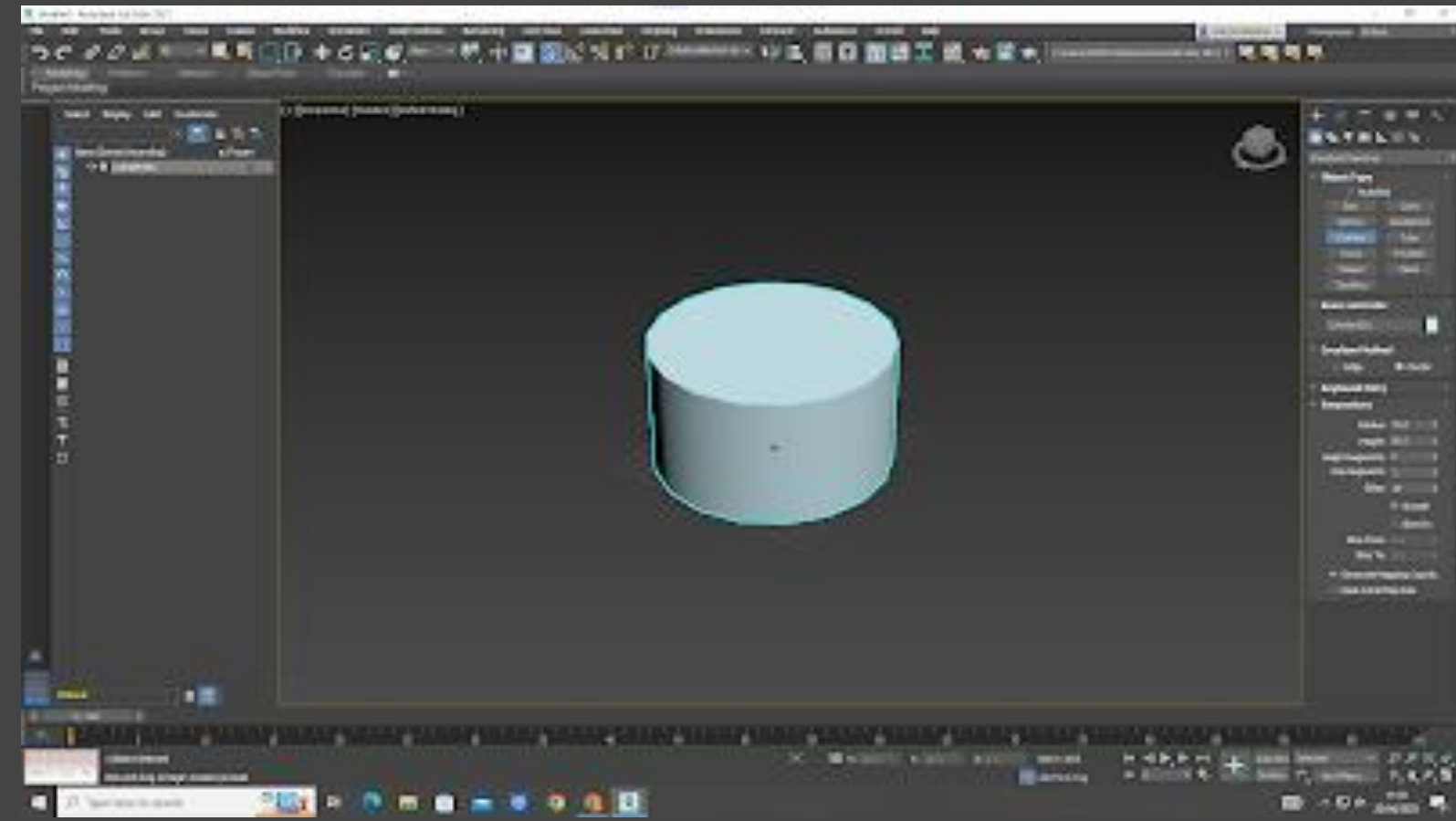

Exerc. 10 – 3D MAX- lâmpada



Exerc. 11 – 3D MAX- materiais





Exerc. 11 – 3D MAX- materiais

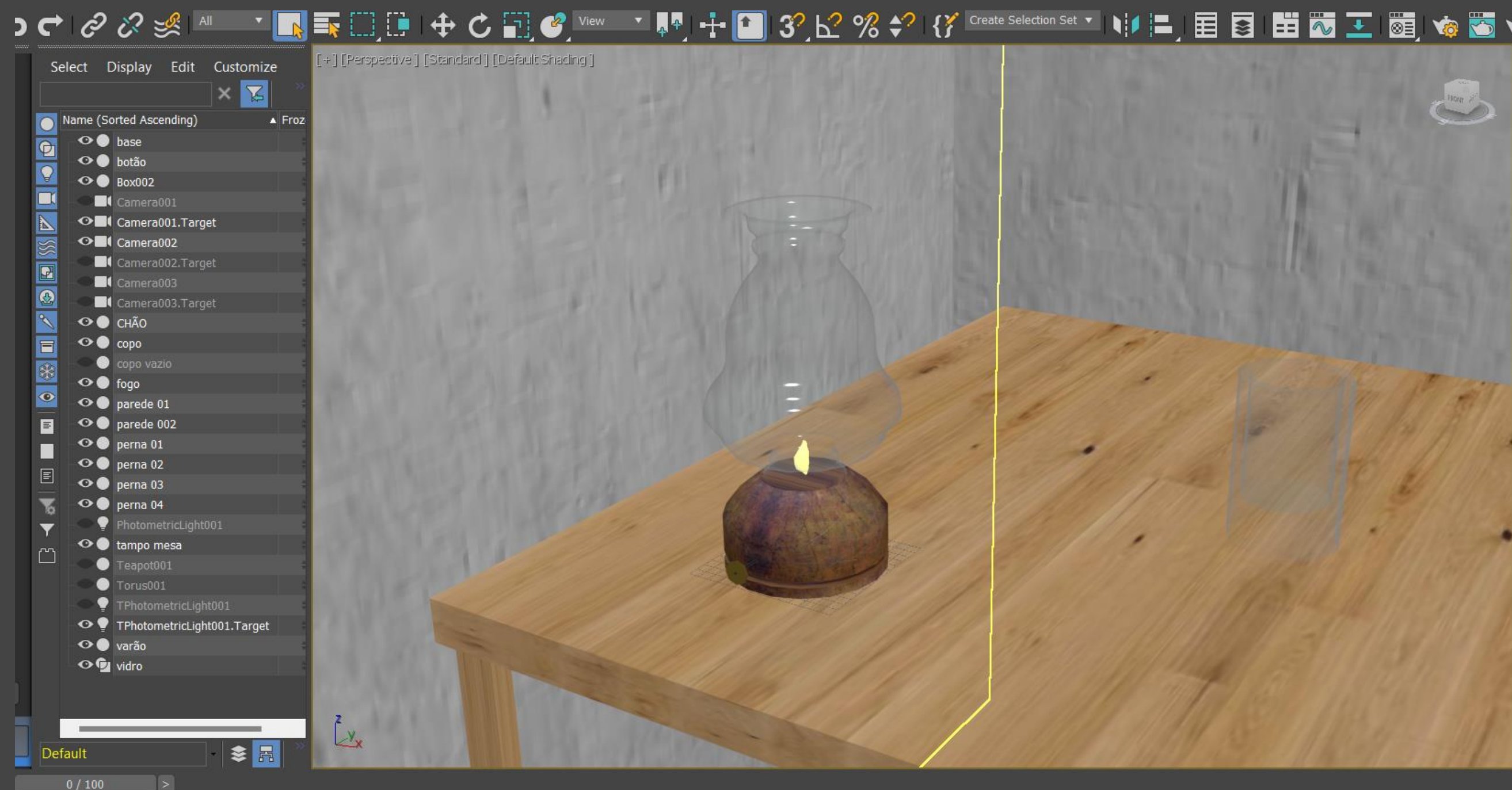

Exerc. 11 – 3D MAX- materiais



Exerc. 11 – 3D MAX- materiais



Exerc. 11 – 3D MAX- materiais



Exerc. 11 – 3D MAX- materiais

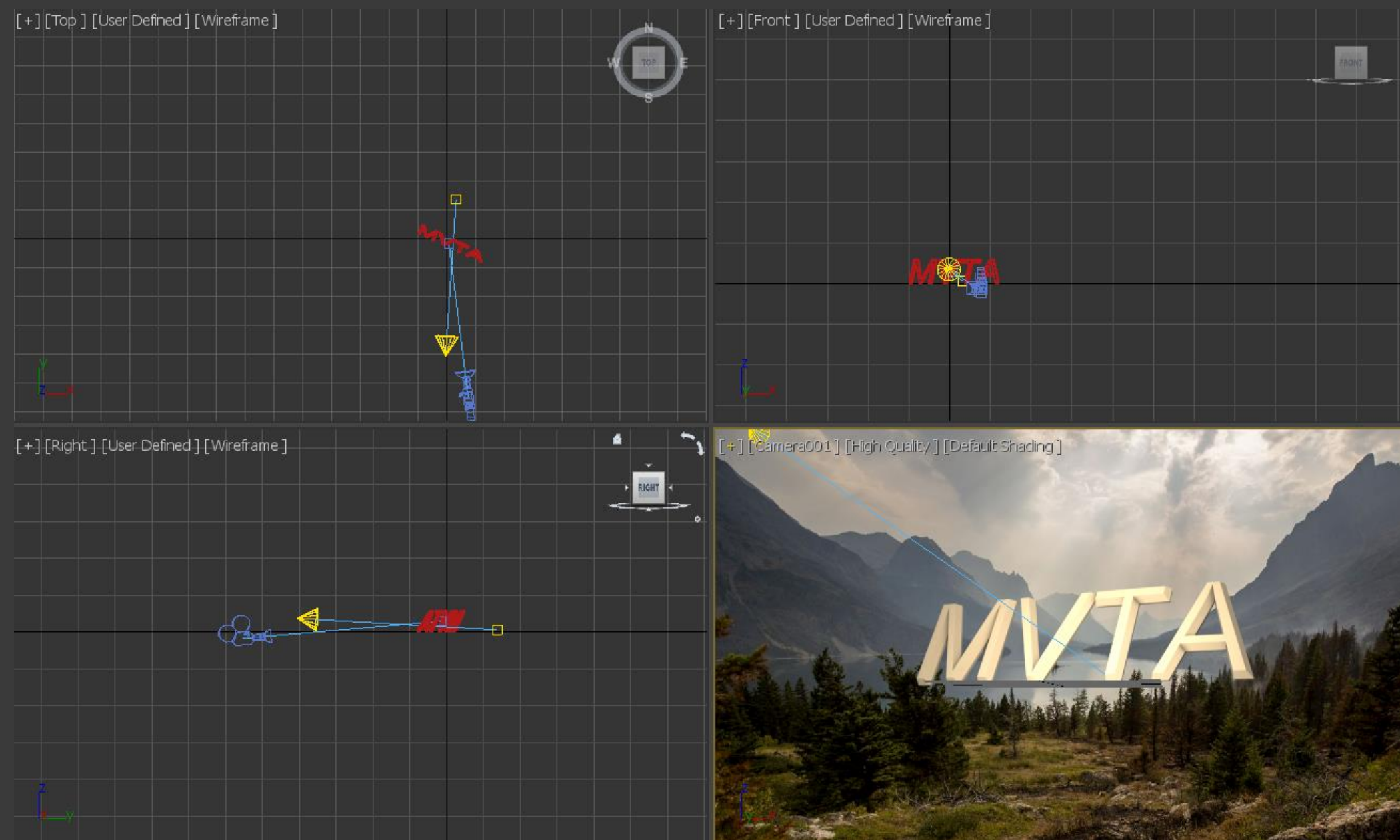

Exerc. 12 – 3D MAX- animação