

MODELAÇÃO GEOMÉTRICA E GENERATIVA



Dylan Regalo Alexandre | 20181016 | 4°F

ÍNDICE

Exercício 01	p.3 e 4
Exercício 02	p.5 e 6
Exercício 02.1	p.7 e 8
Exercício 03	p.9 e 10
Exercício 04	p.11 e 12
Exercício 05	p.13
Exercício 06	p.14 e 15
Exercício 07	p.16 e 17
Exercício 08	p.18 a 21
Exercício 09	p.22 a 25
Exercício 10	p.26 a 28
Exercício 11	p. 29
Exercício 12	p. 30

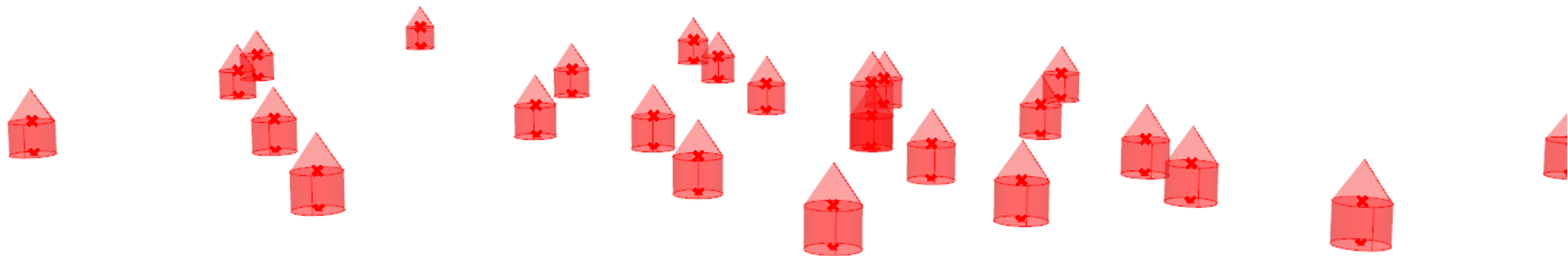

Ex01 - Cabana

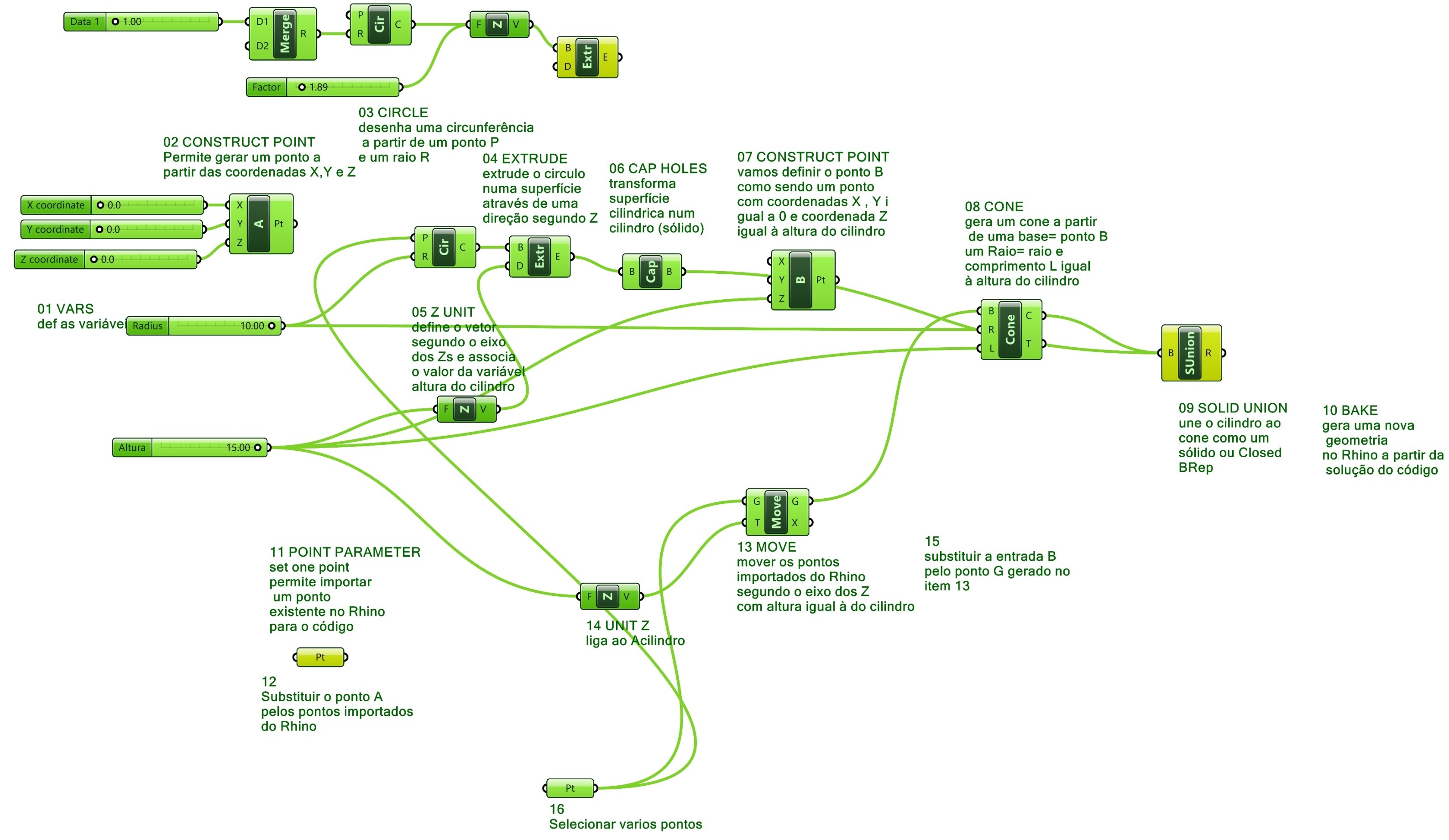

Ex01- Cabana

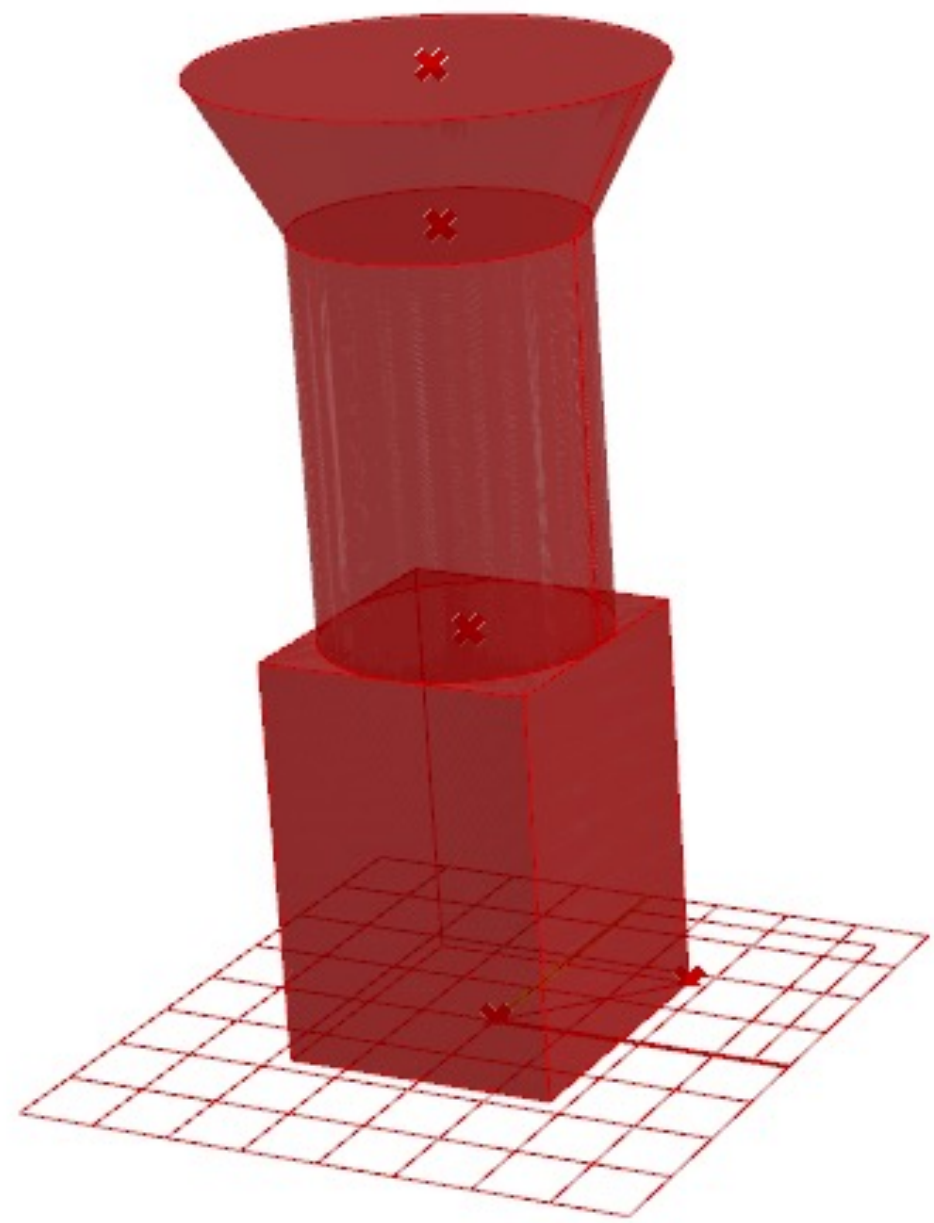

Ex02- Coluna

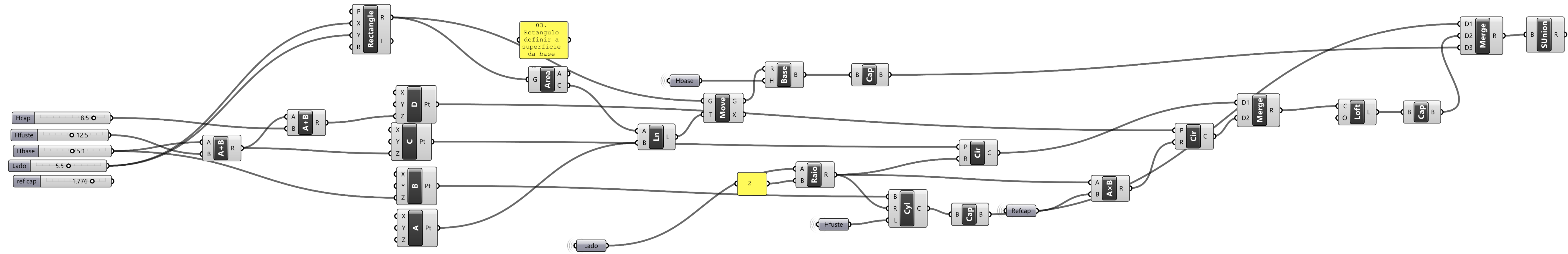

01. Definir variáveis
02. Definir pontos de referências segundo coordenadas XYZ de acordo com as respectivas alturas de cada elemento
03. Retângulo definir a superfície da base
04. Área Arranjar o centro do retângulo
05. Move Mover a superfície da base para o ponto A
06. Boxrec Criar um paralelepípedo a partir do retângulo de uma altura
07. Cylinder criar um cilindro a partir de um ponto de Base: um raio e uma altura
08. Circle definir o círculo de base para o capitel, segundo um ponto de base (pt C) e um Raio
09. Loft criar a superfície entre as duas curvas
10. solid union unir os sólidos das diferentes superfícies

Ex02- Coluna



Ex02.1- Coluna

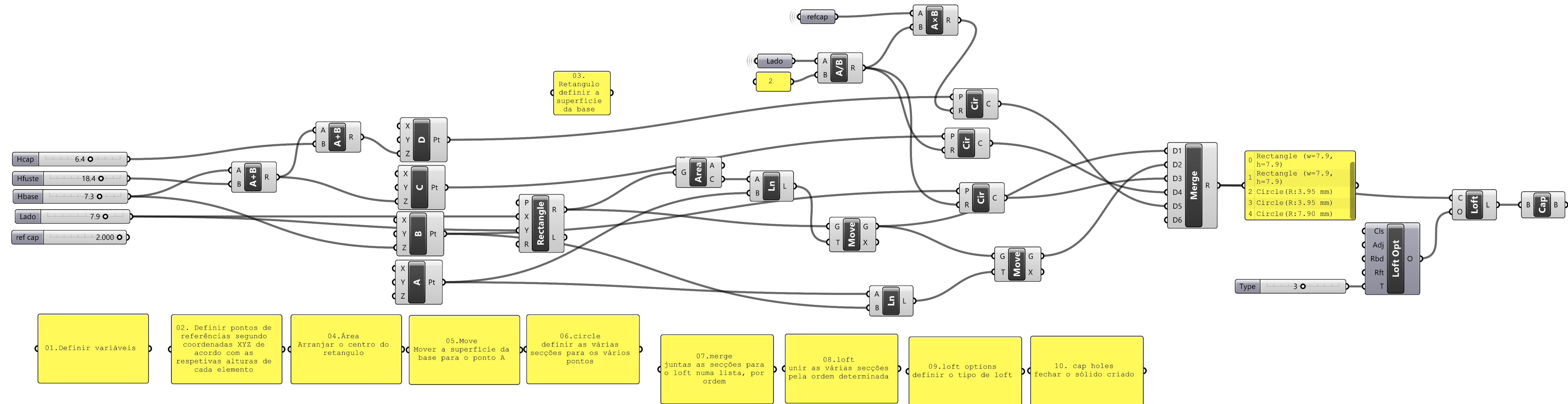

Ex02.1- Coluna

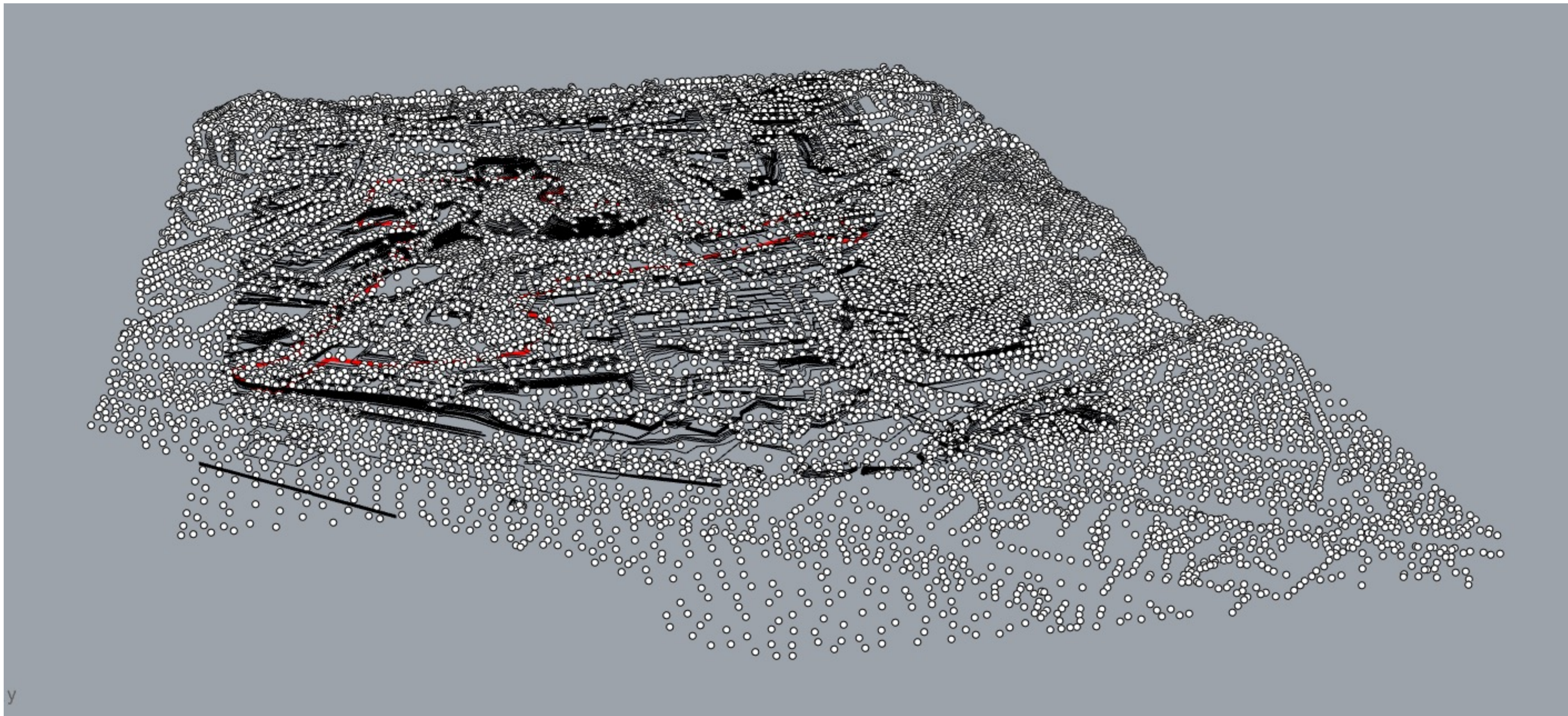

Ex03- Pontos Cotados

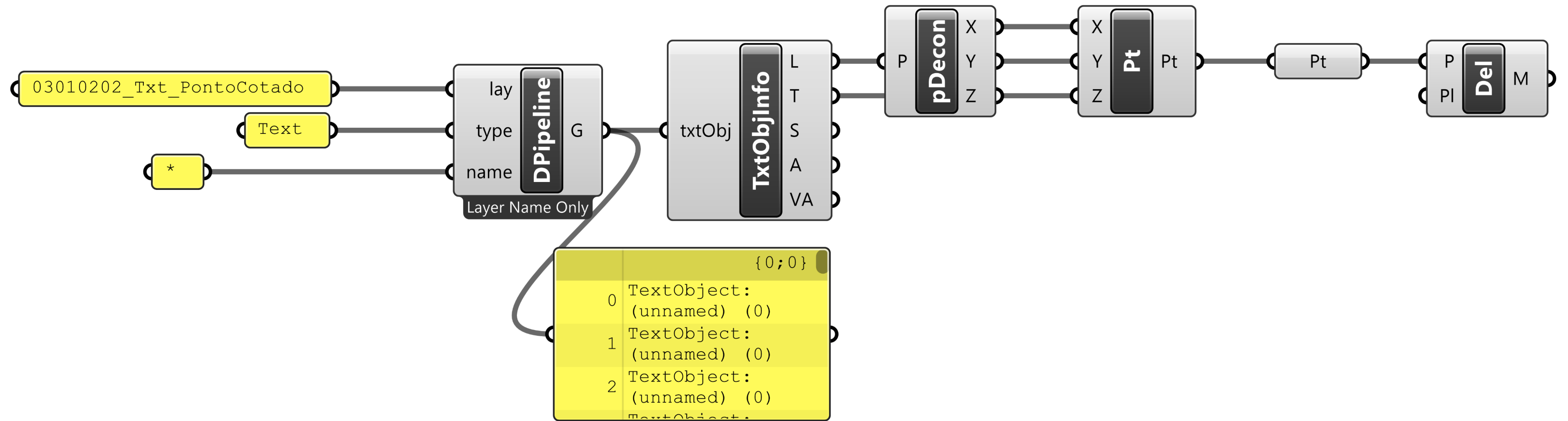

Ex03- Pontos Cotados

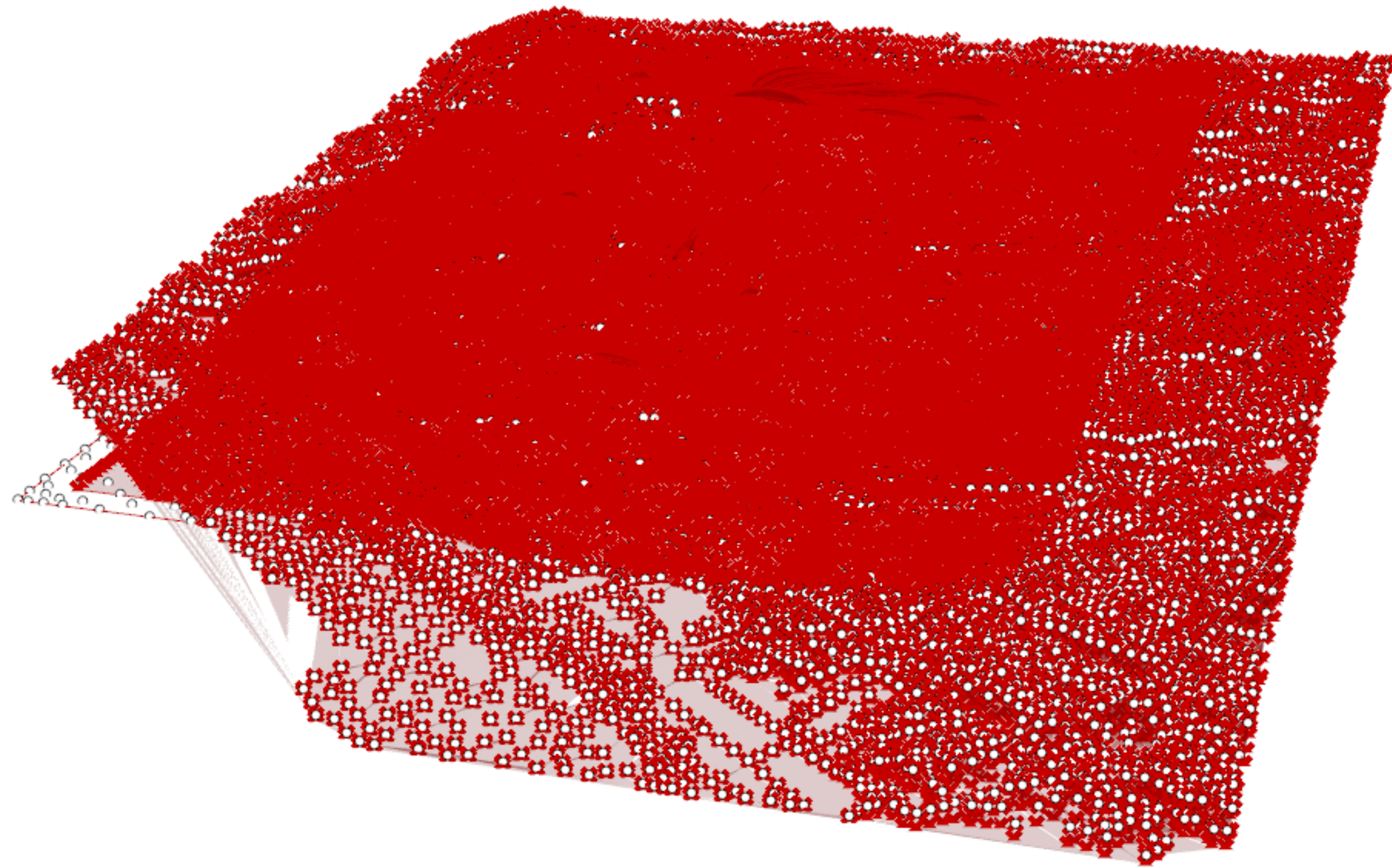

Ex04-Terreno

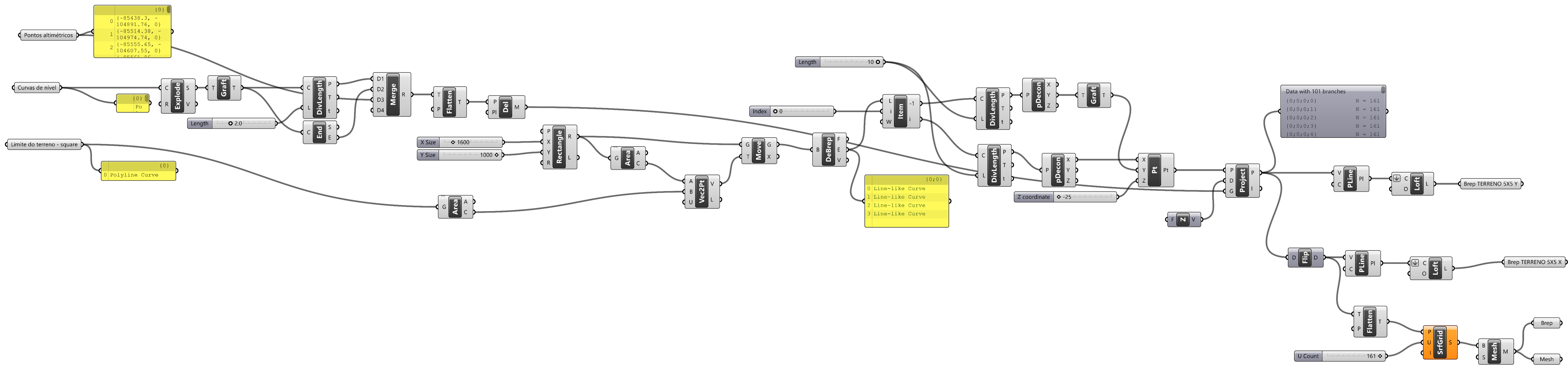

Ex04-Terreno



Ex05-Mapear Terreno com Imagem Satélite



Ex06- Inserir Edifício na Superfície do Terreno

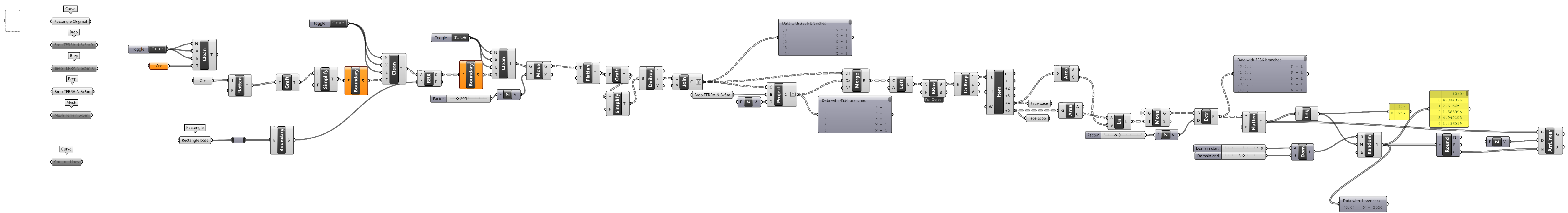

Ex06- Inserir Edifício na Superfície do Terreno



Ex07-Desenho Paramétrico e Morfogénese Digital

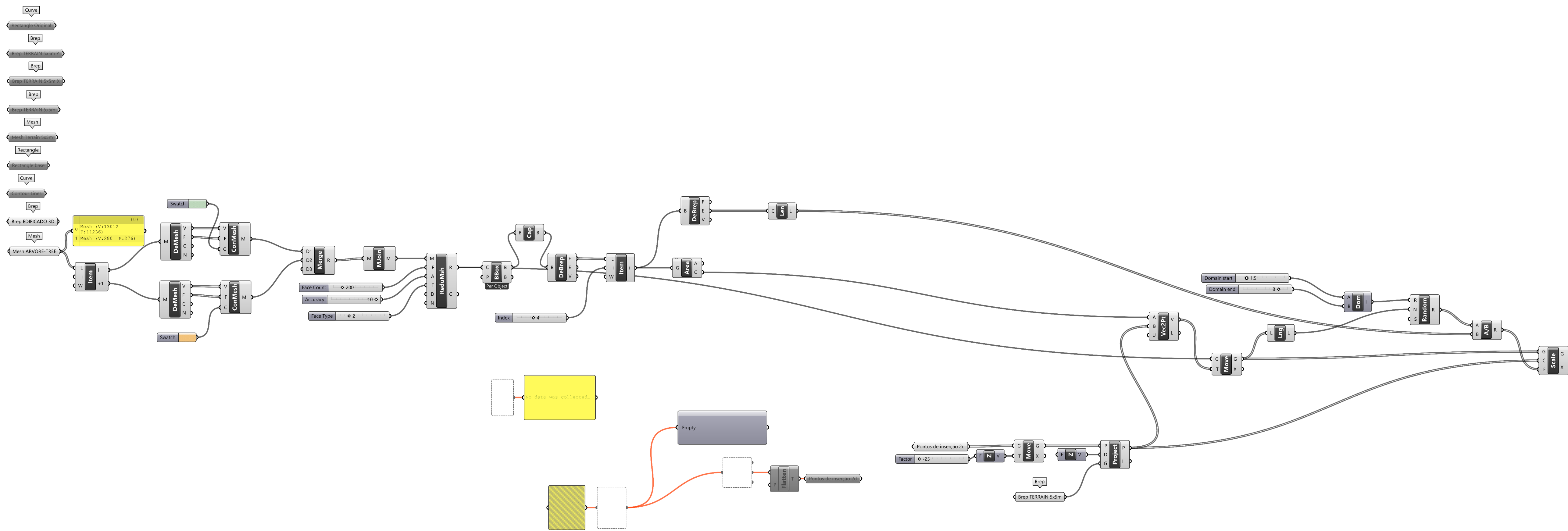
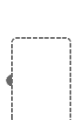

Ex07-Desenho Paramétrico e Morfogénesse Digital

EX8.1 SERPENTINA/ SPIRULA

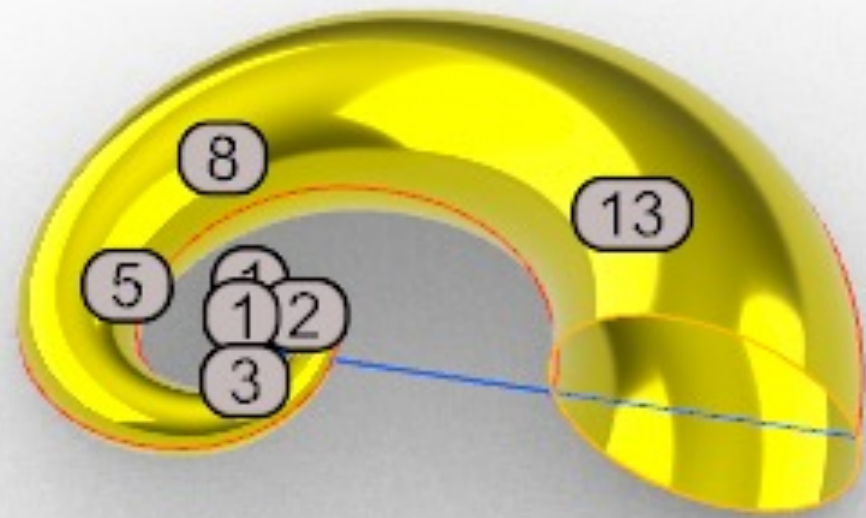

EX8.2 PLANORBI

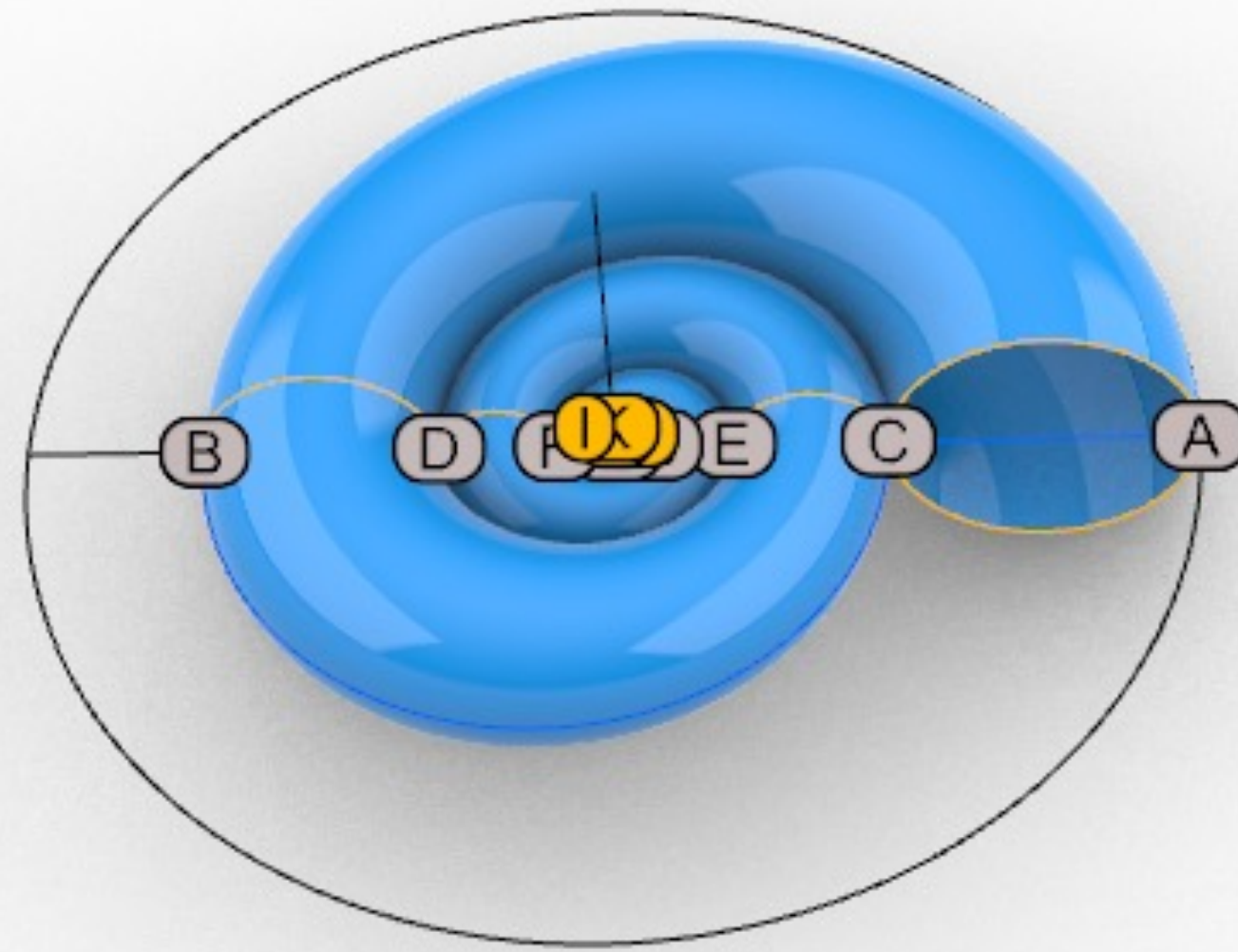

EX8.3 NAUTILUS

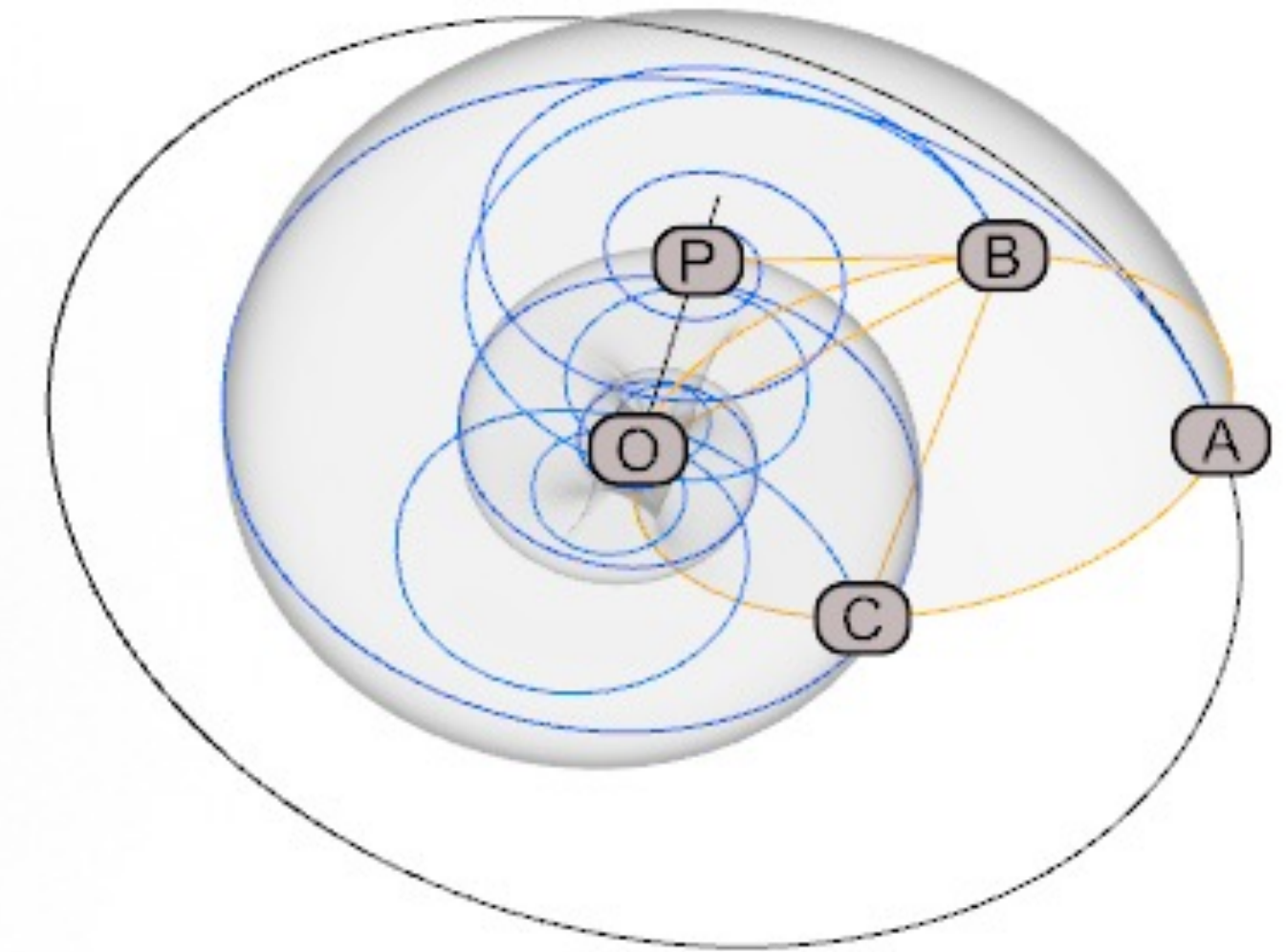

Ex08-Construção de Superfícies complexas a partir da Morfogénese de Cefalópodes

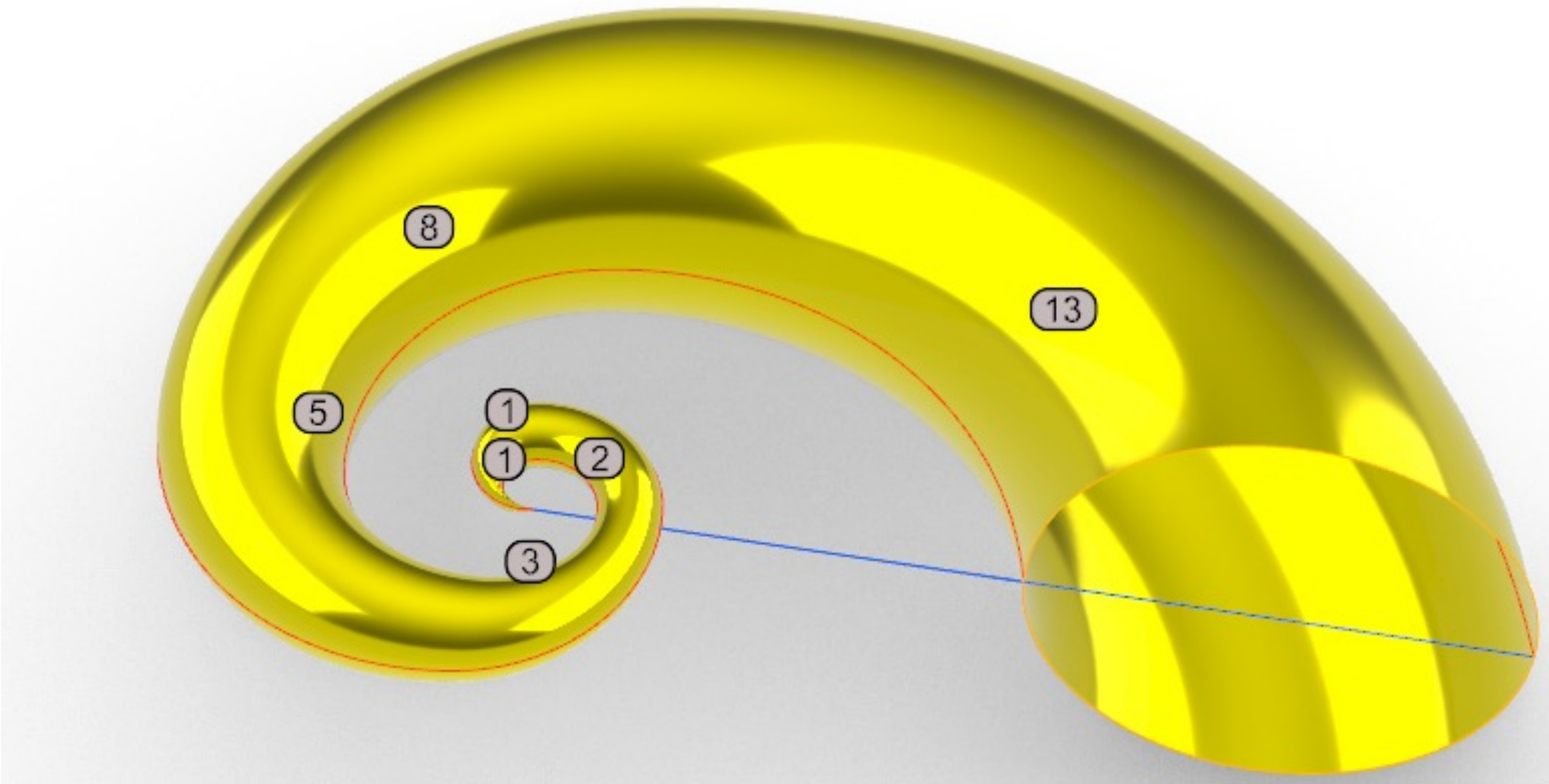
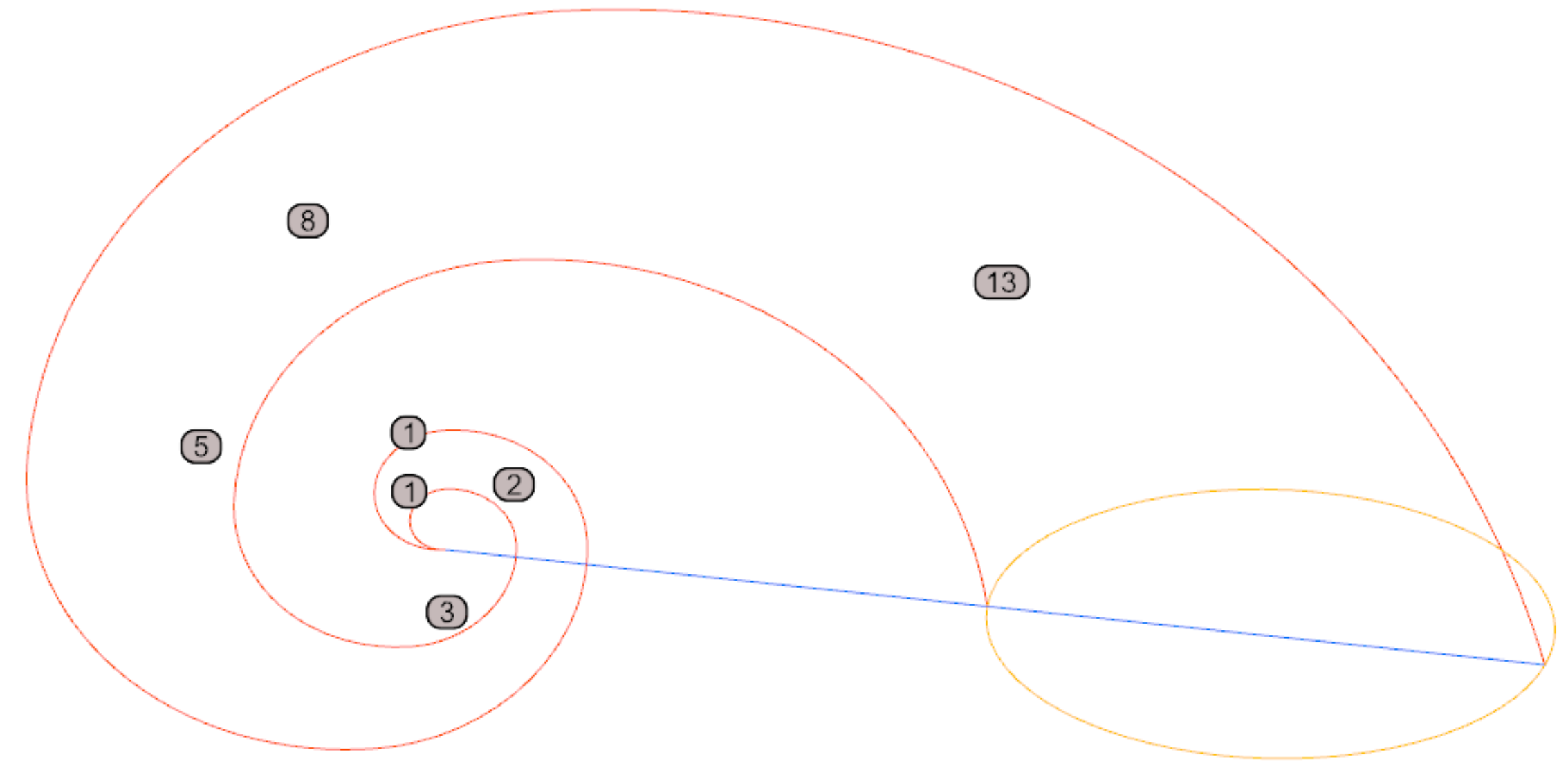

Ex08.1-Serpentina/Spirula

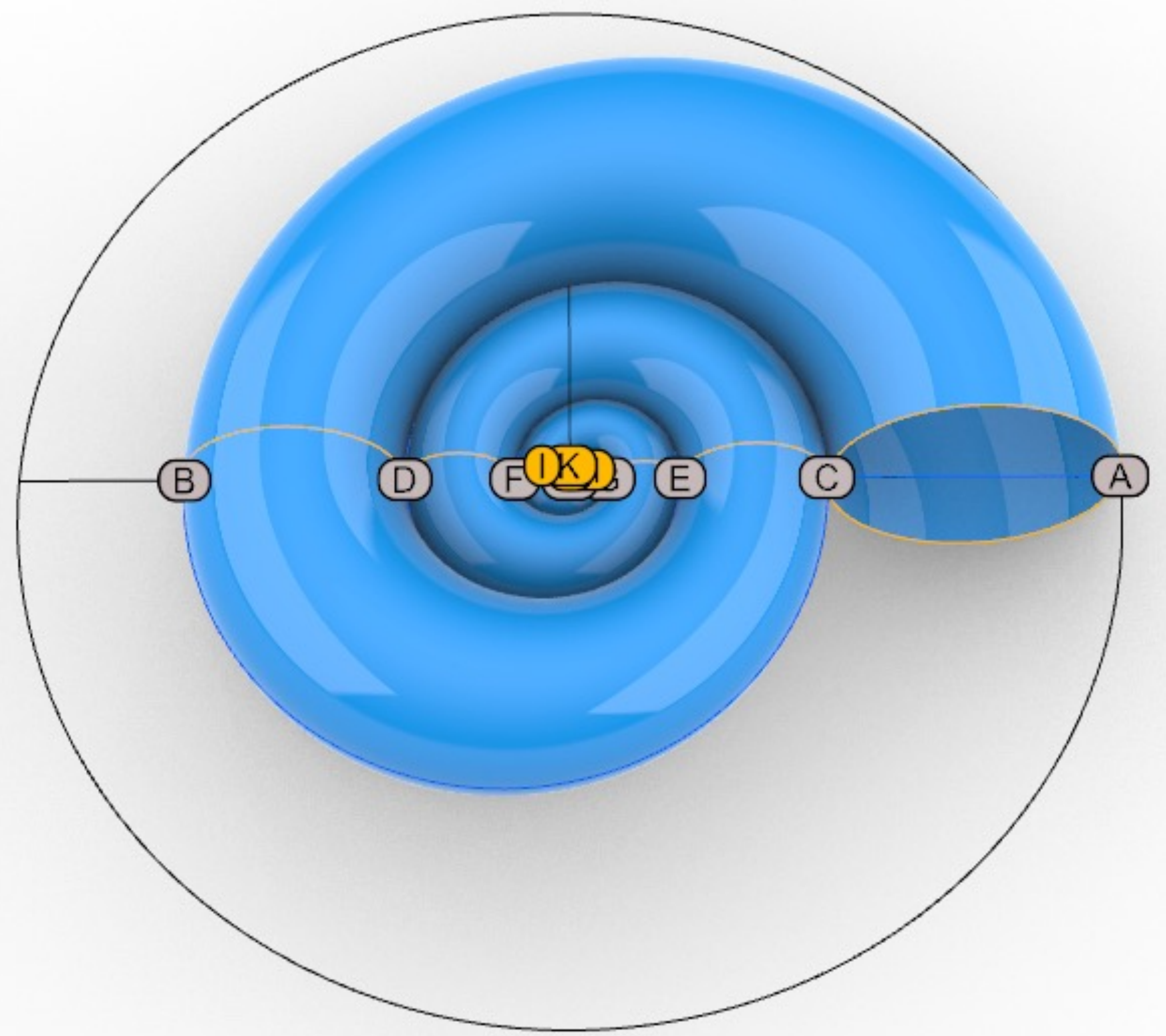
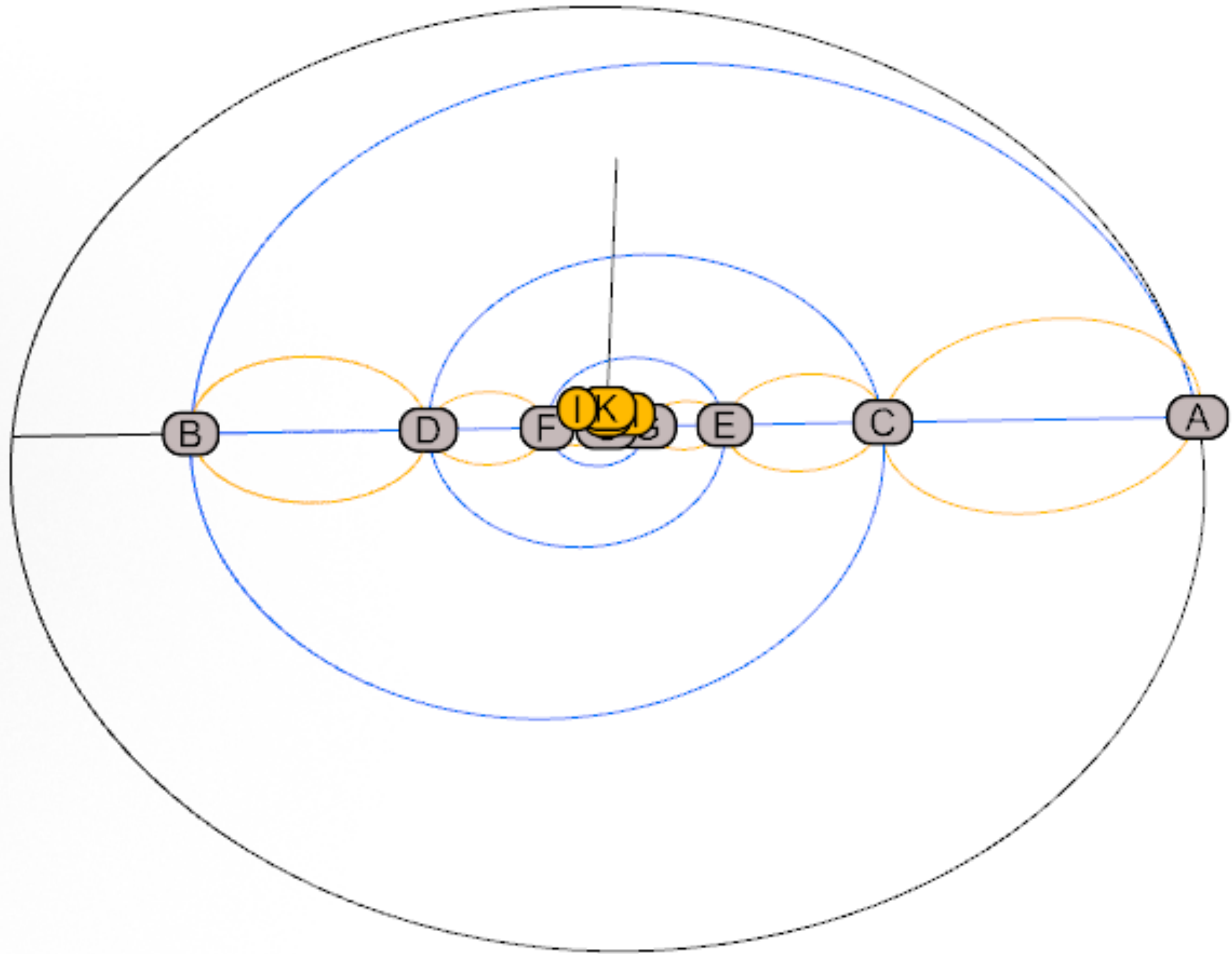

Ex08.2-Planorbi

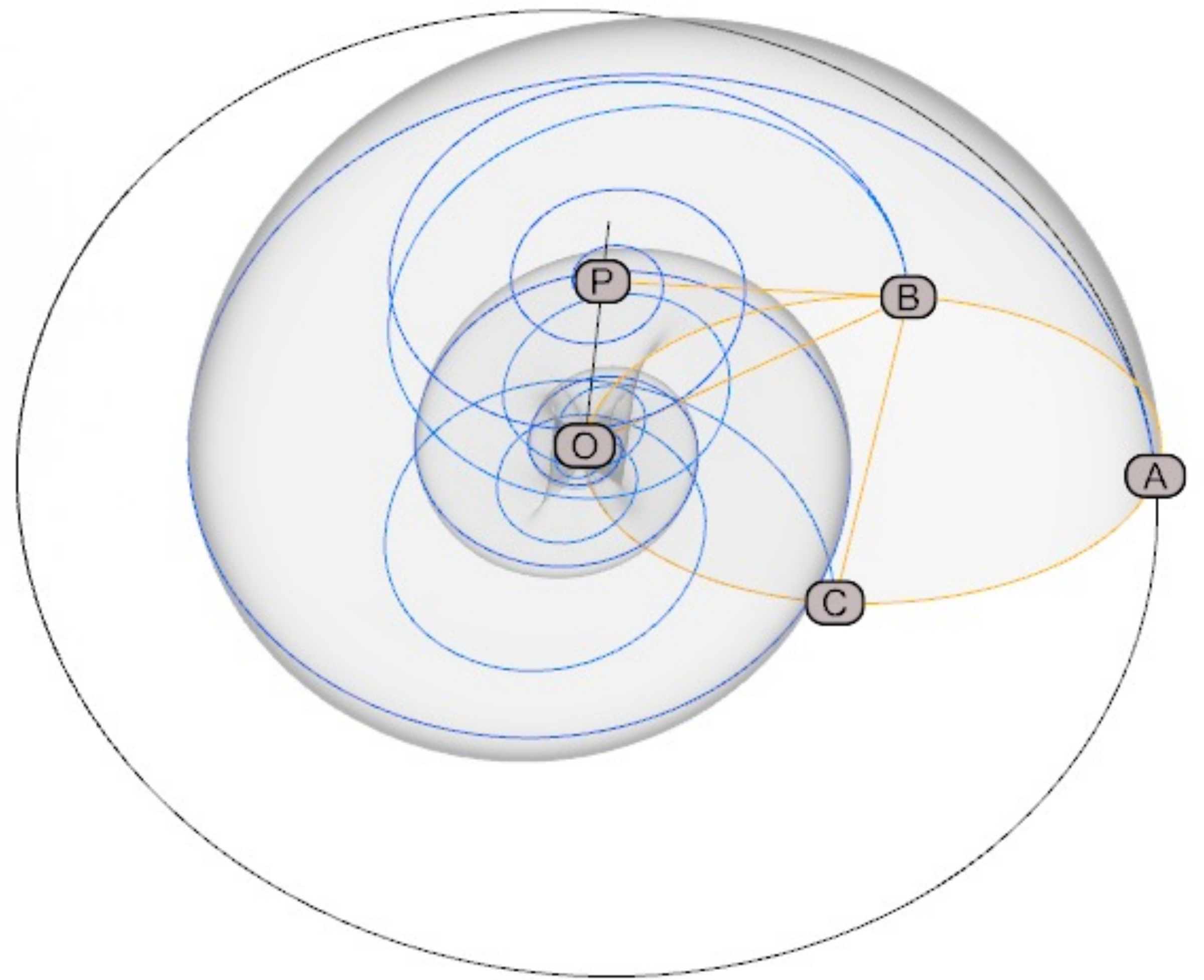
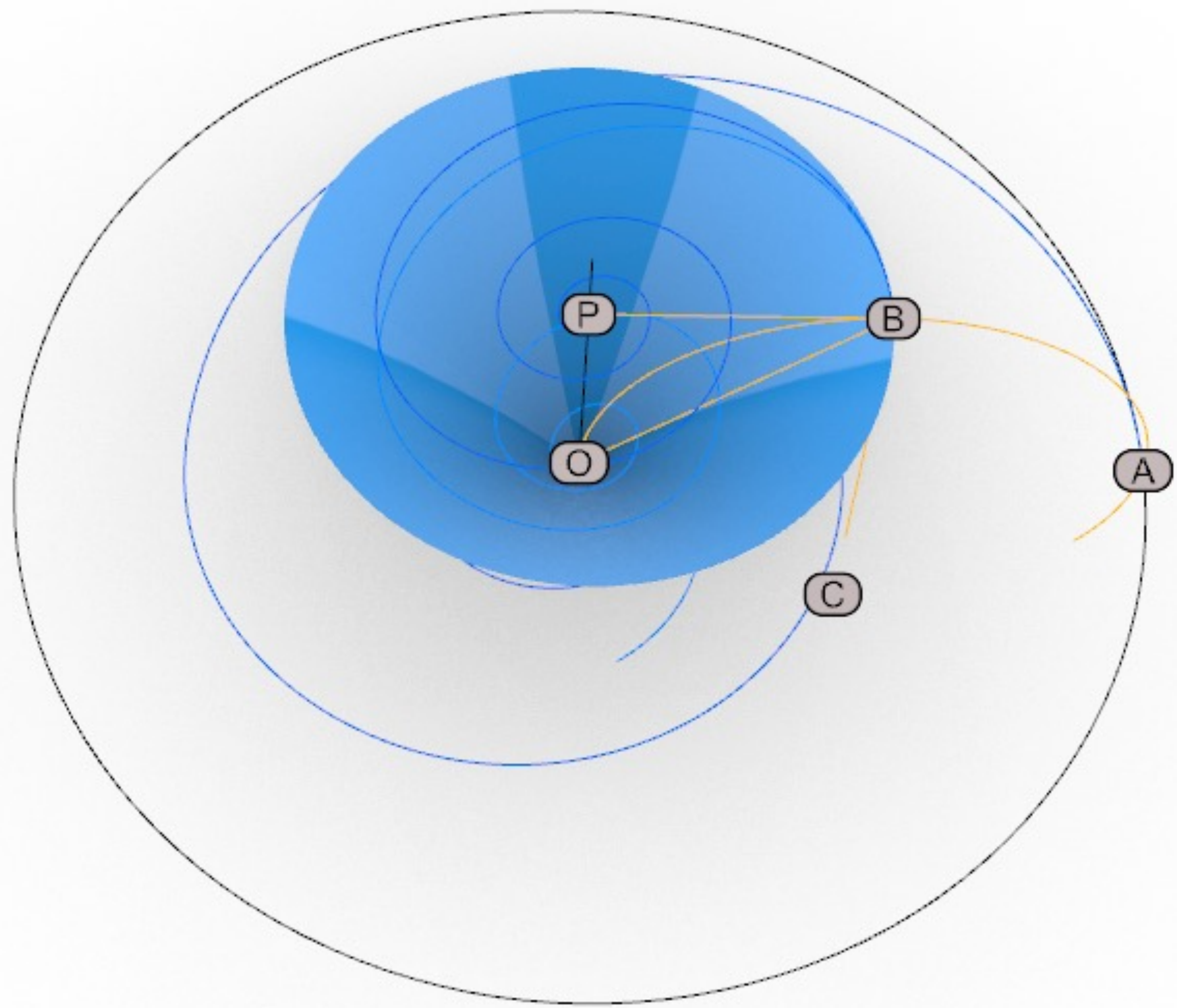

Ex08.3-Nautilus

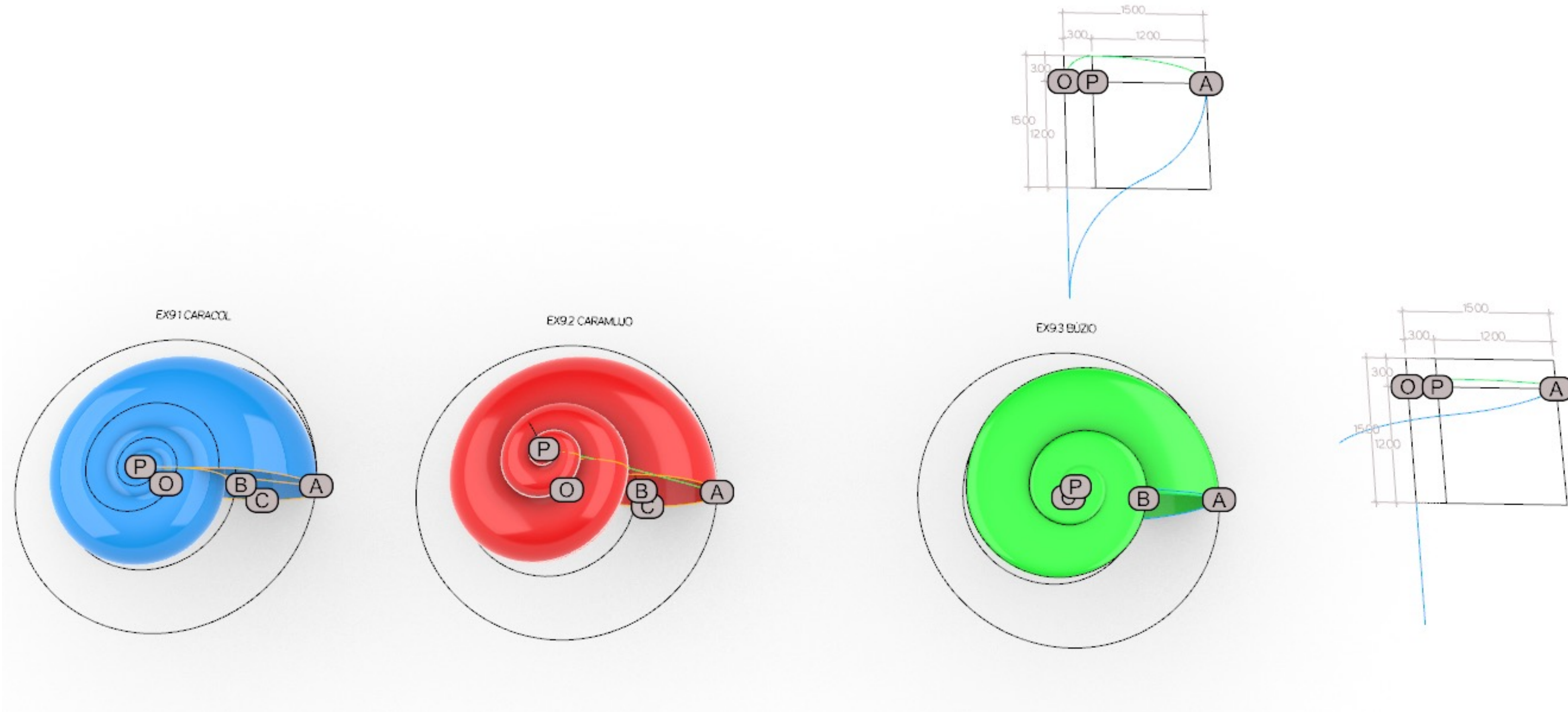

Ex09- Construção de Superfícies complexas a partir da Morfogénese de Gastrópodes

EX9.1 CARACOL

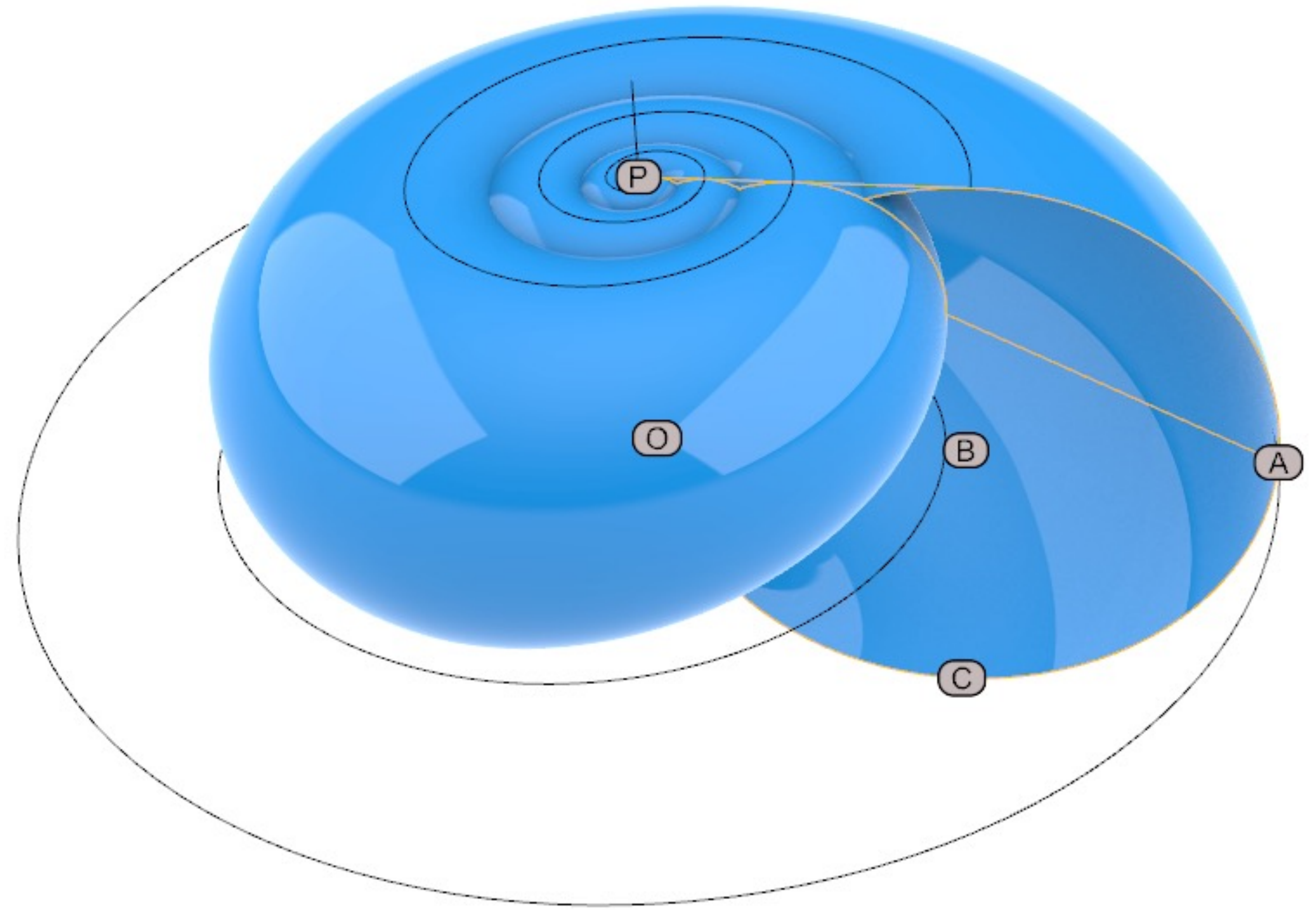
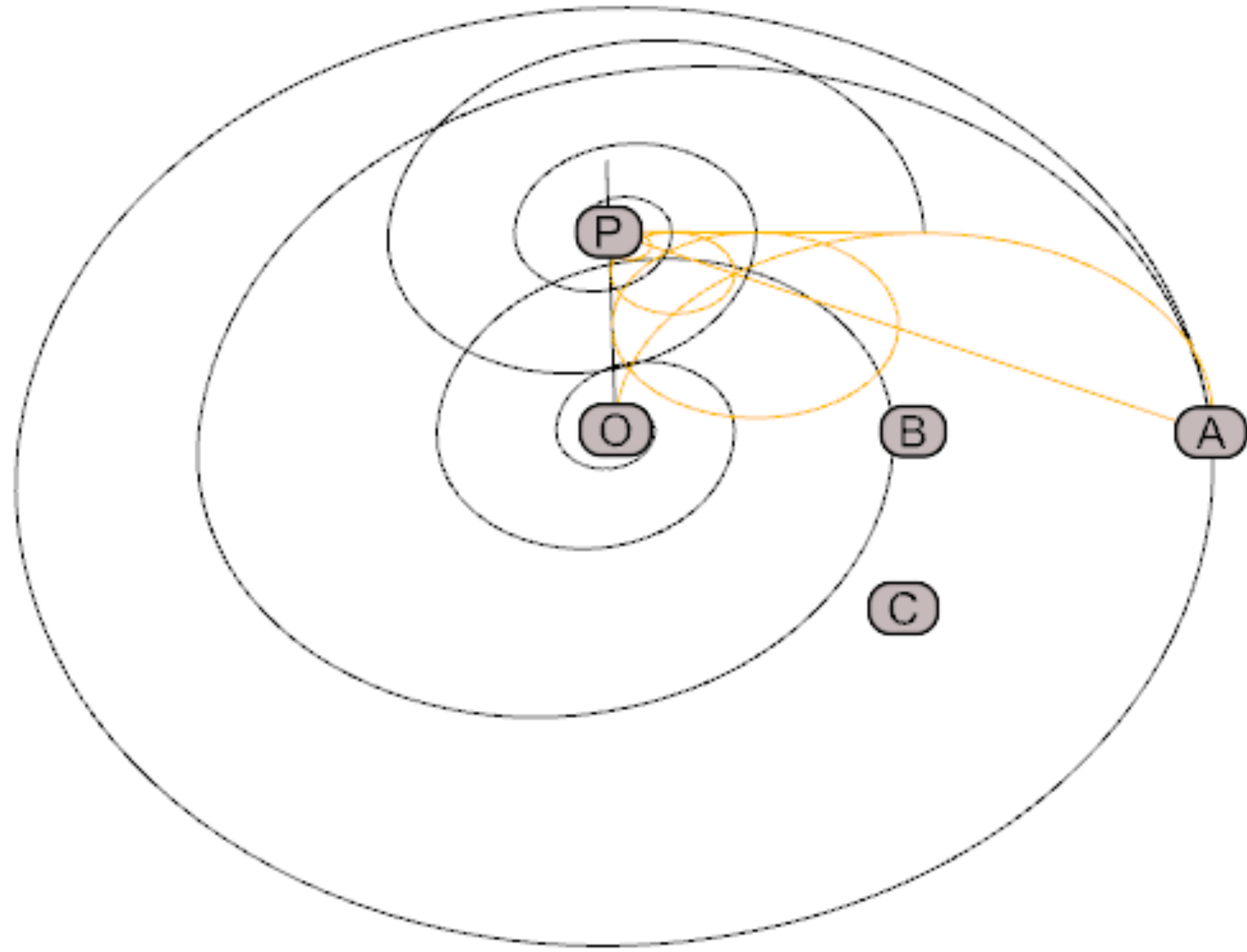

Ex09.1-Caracol

EX9.2 CARAMUJO

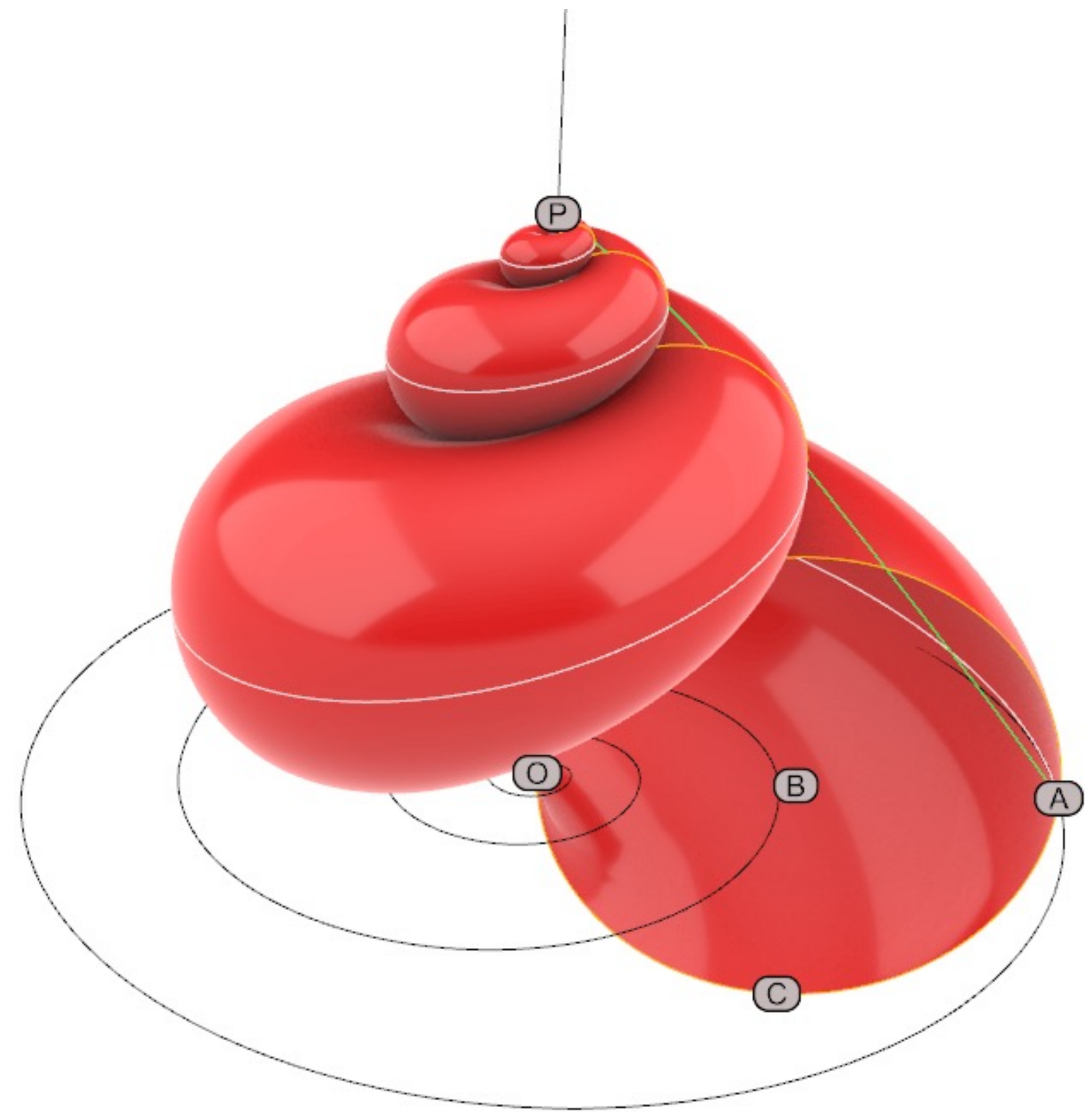
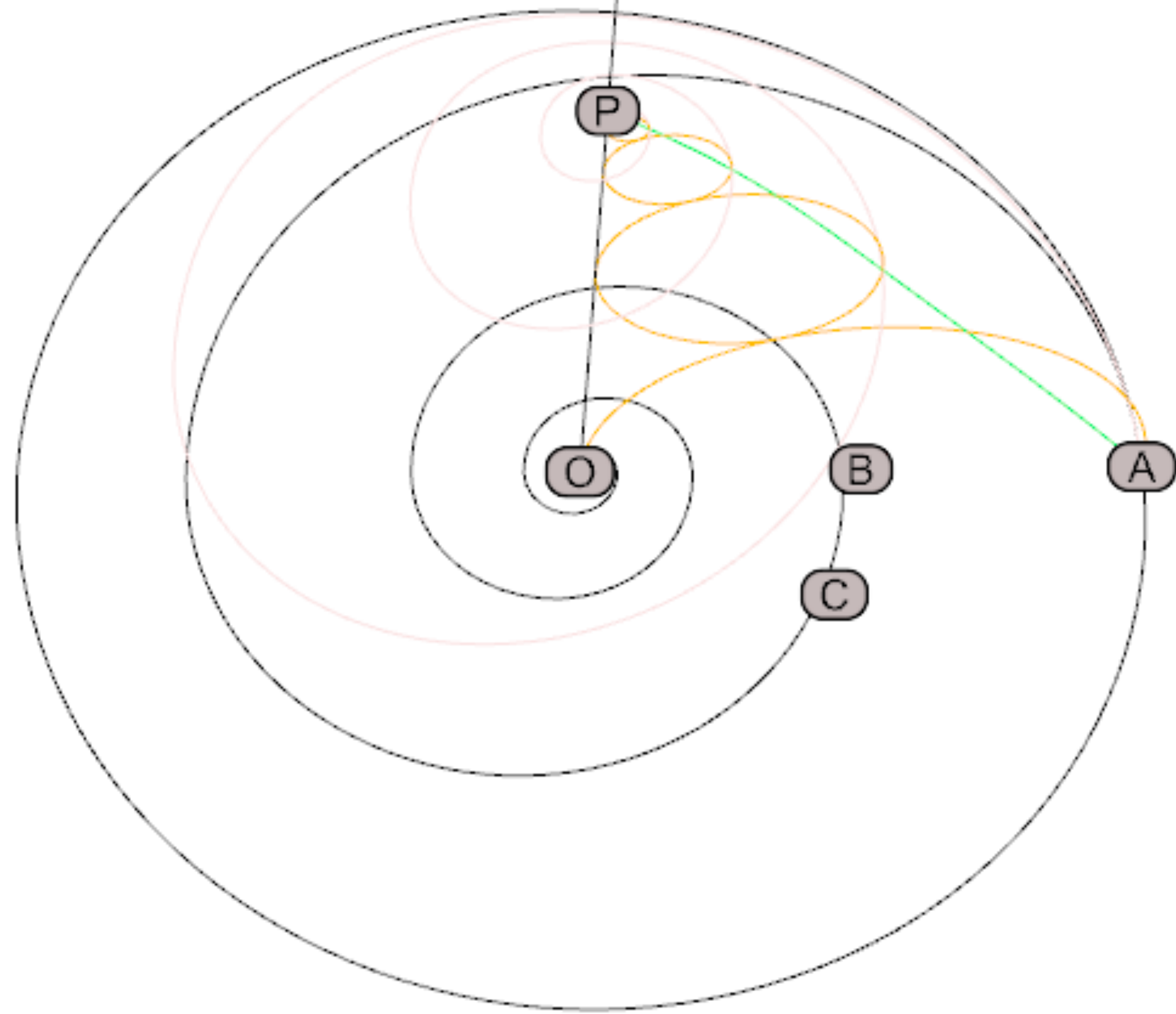

Ex09.2-Caramujo

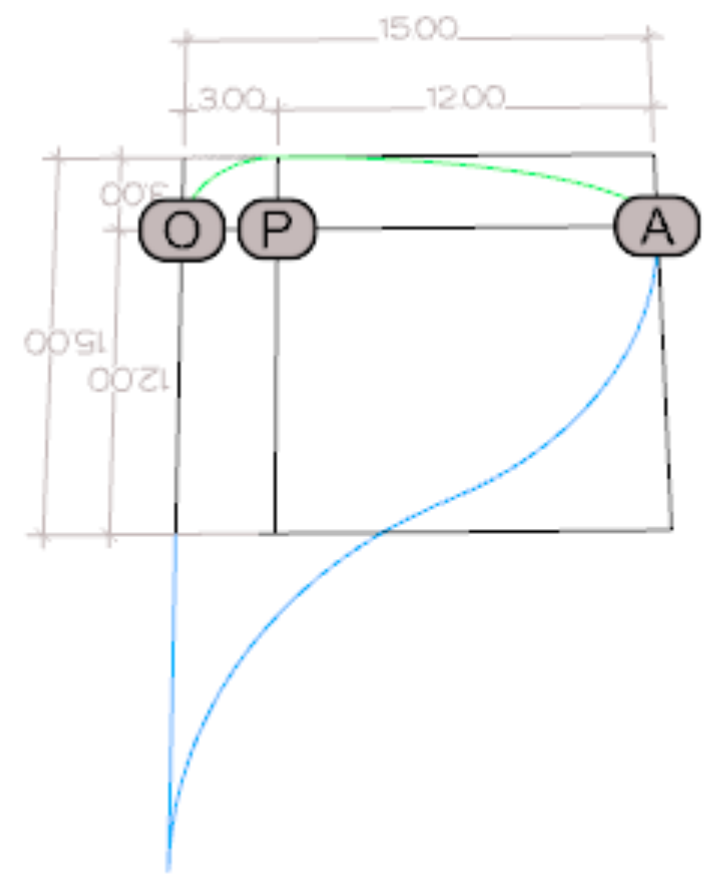

EX9.3 BÚZIO

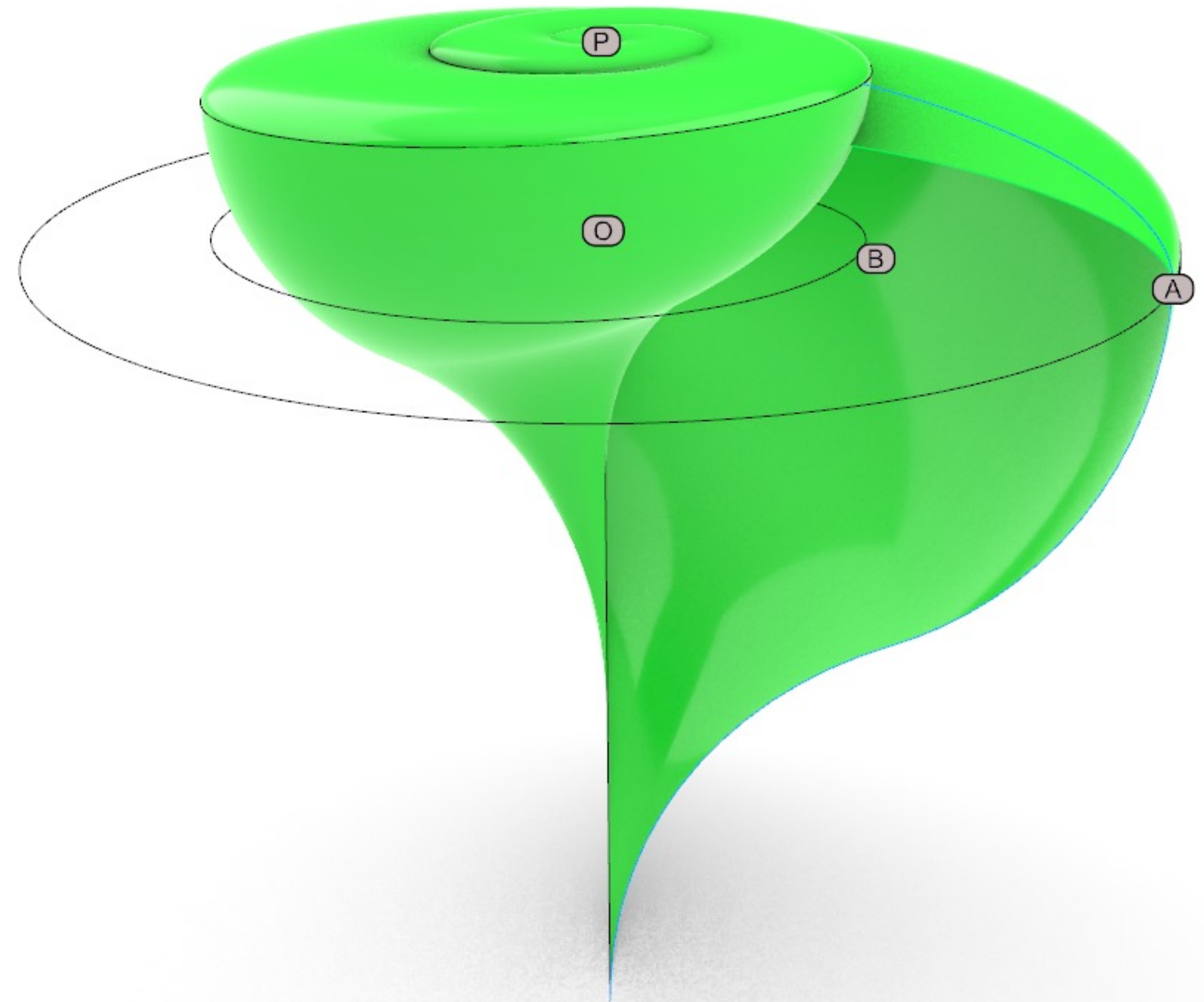
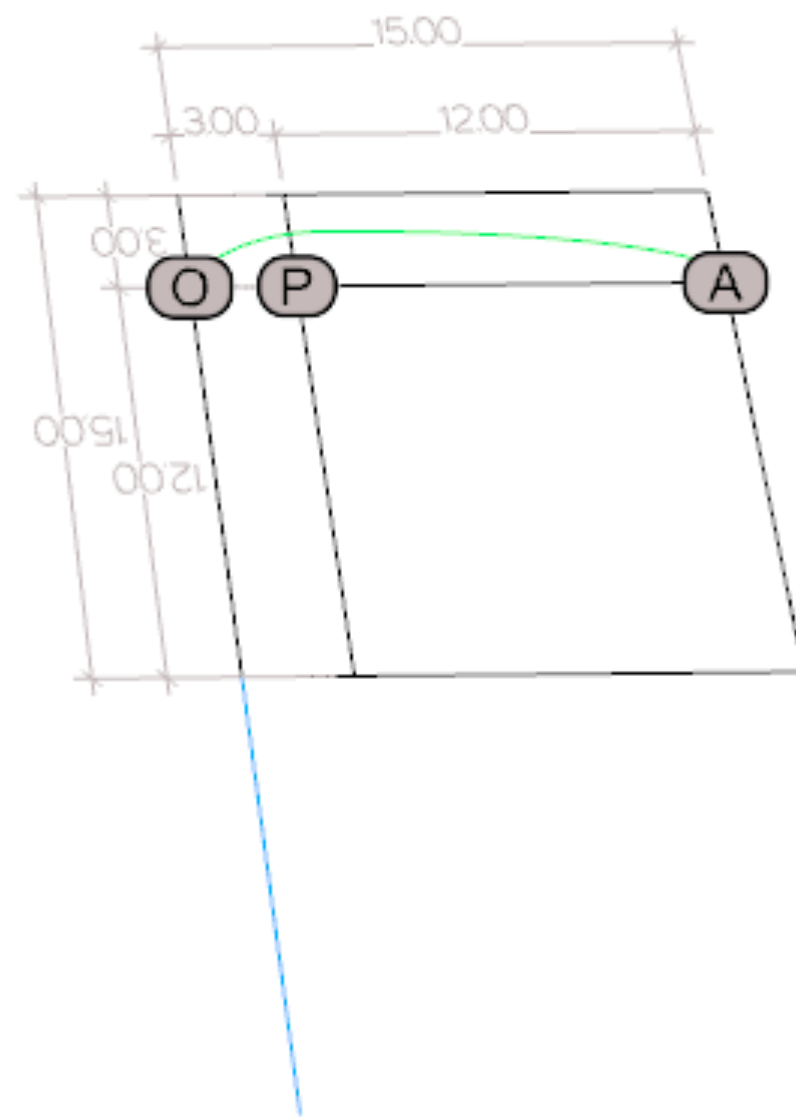
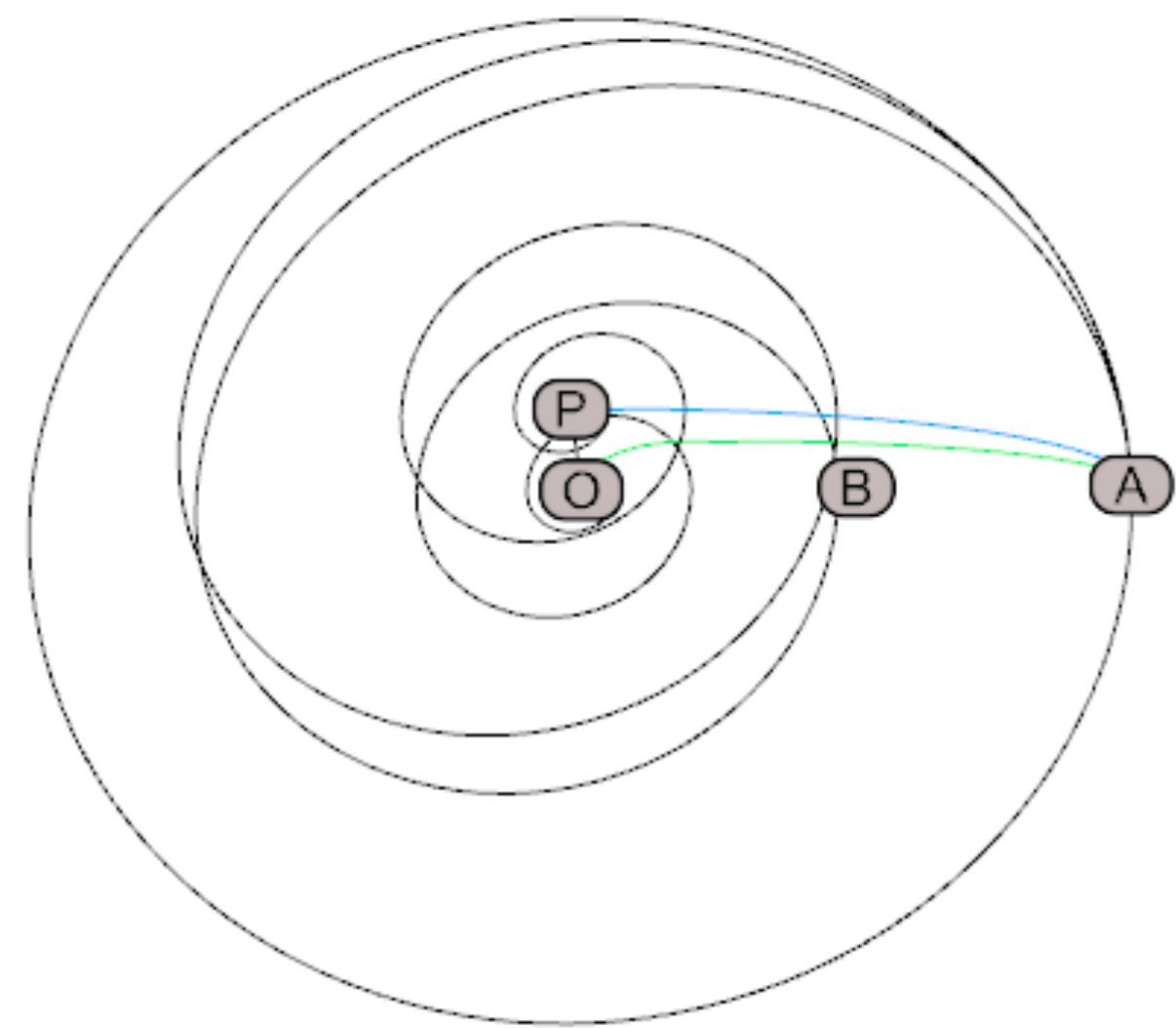

Ex09.3-Búzio

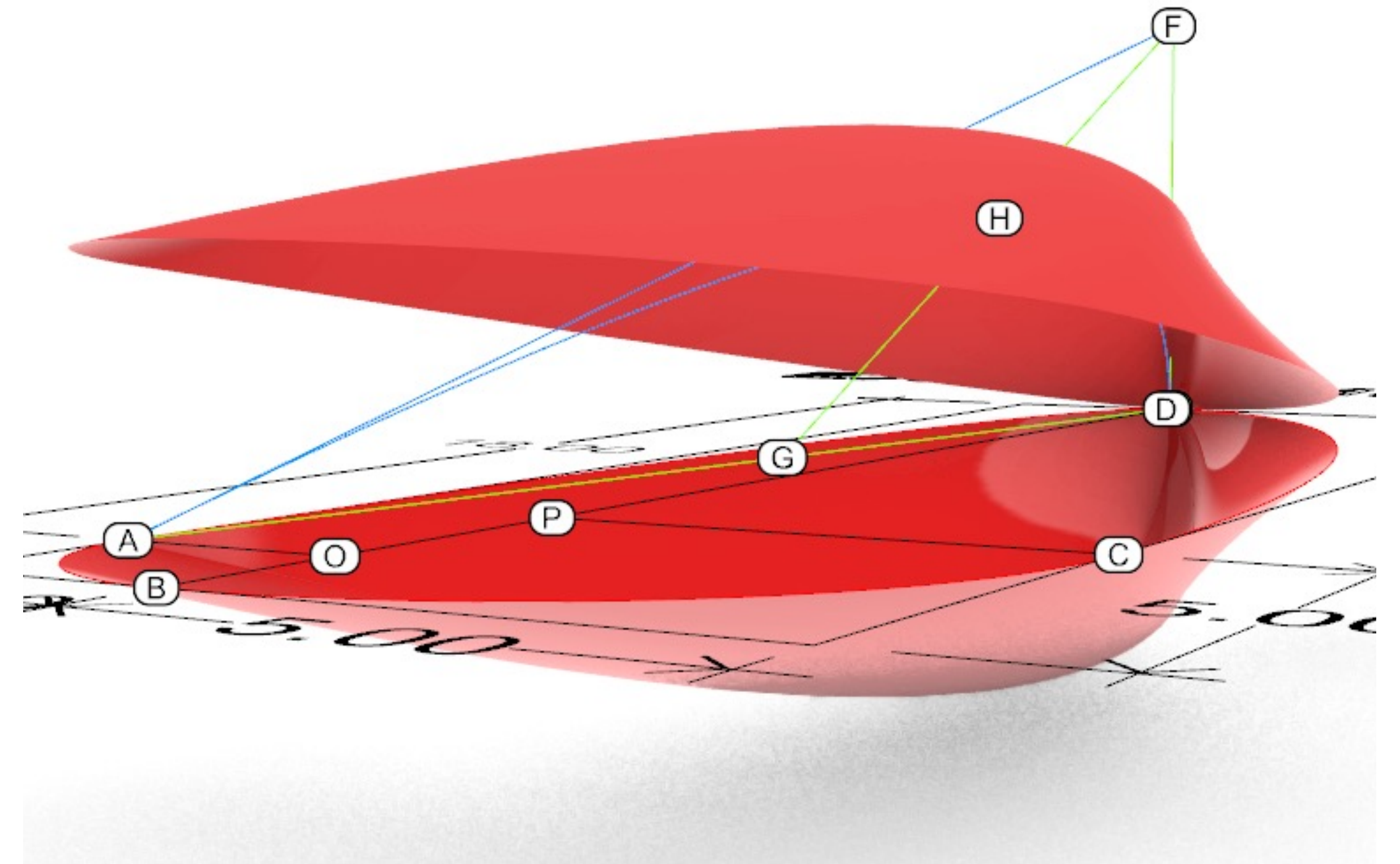
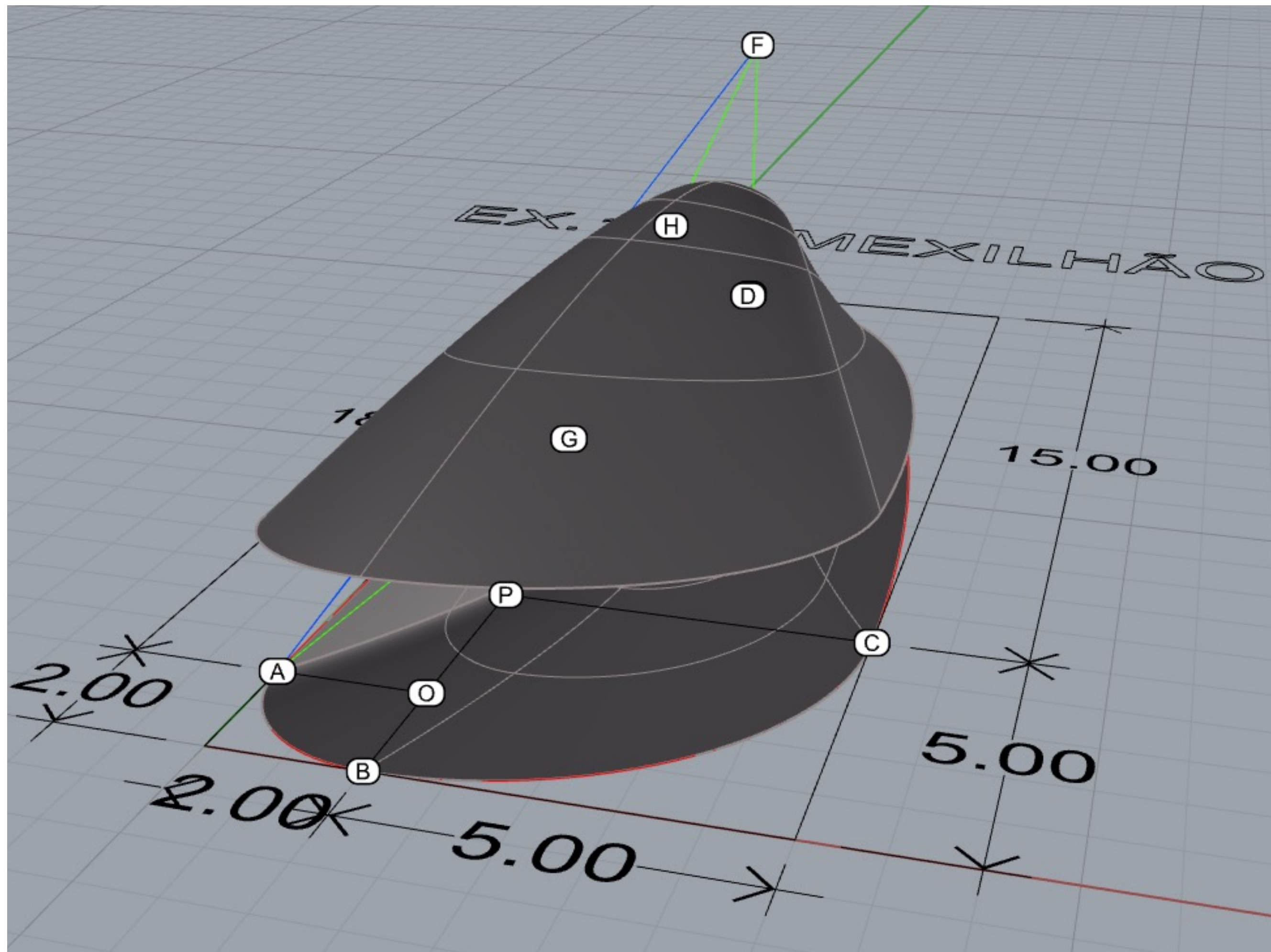

Ex10.1-Mexilhão

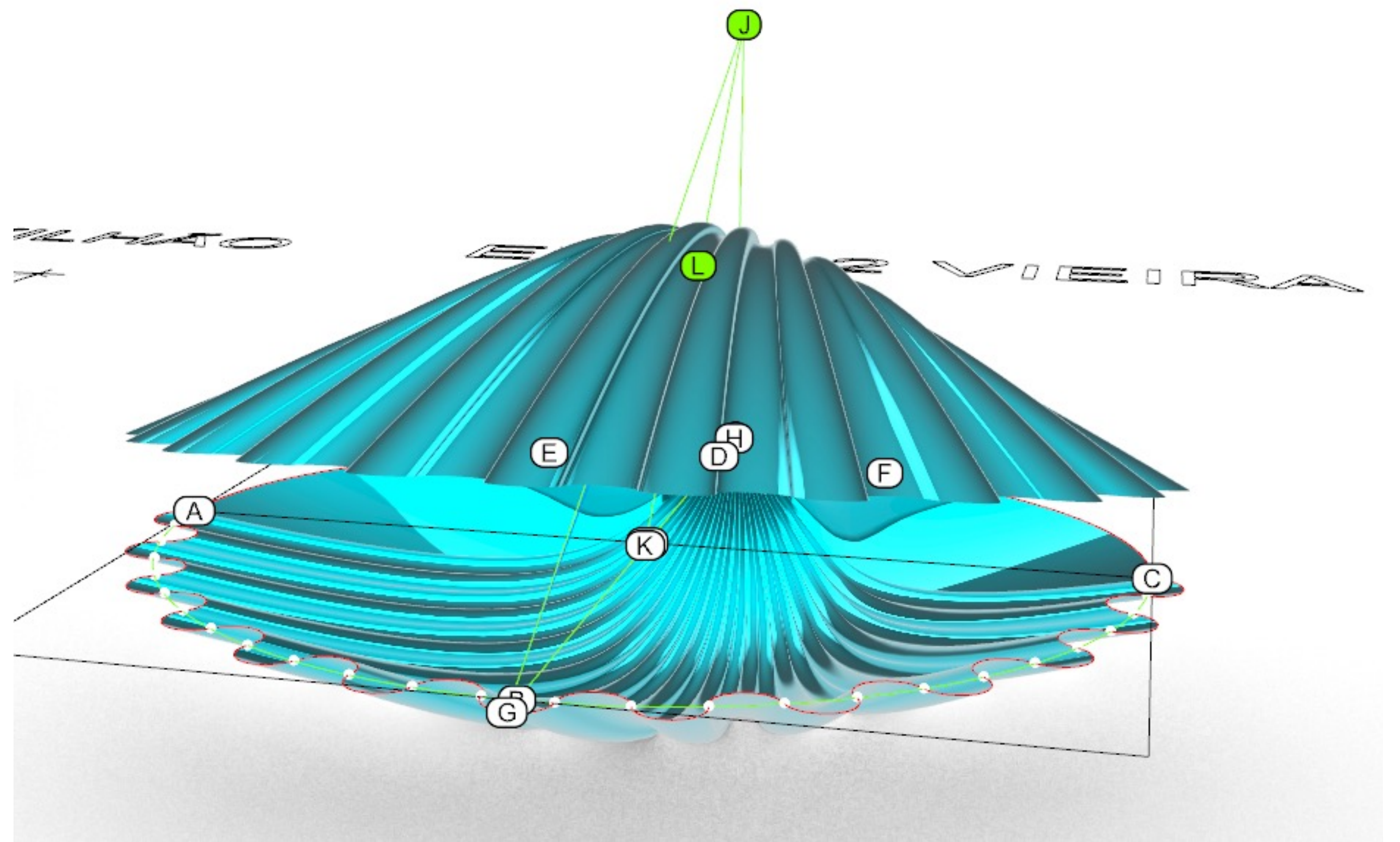
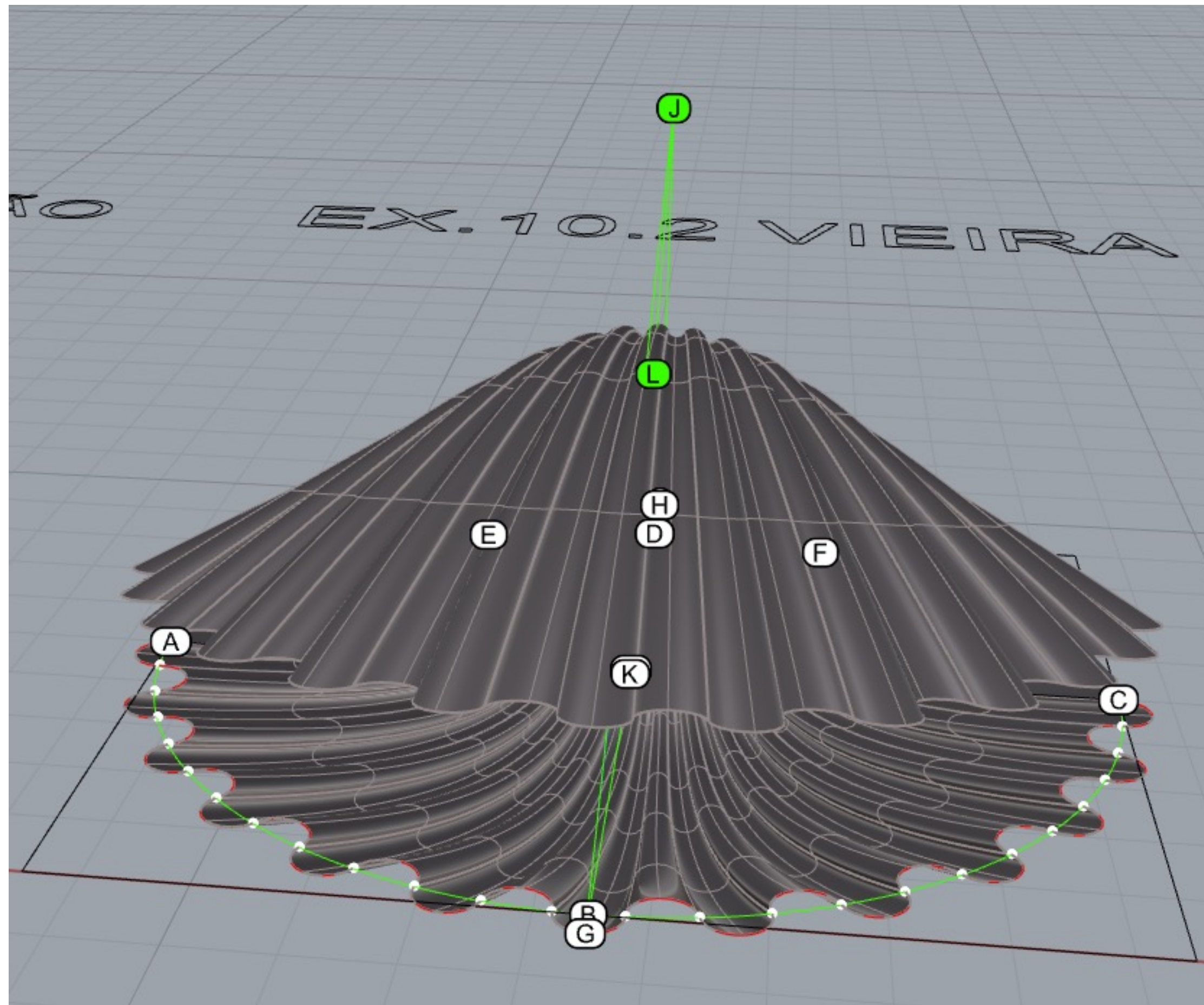

Ex10.2- Vieira

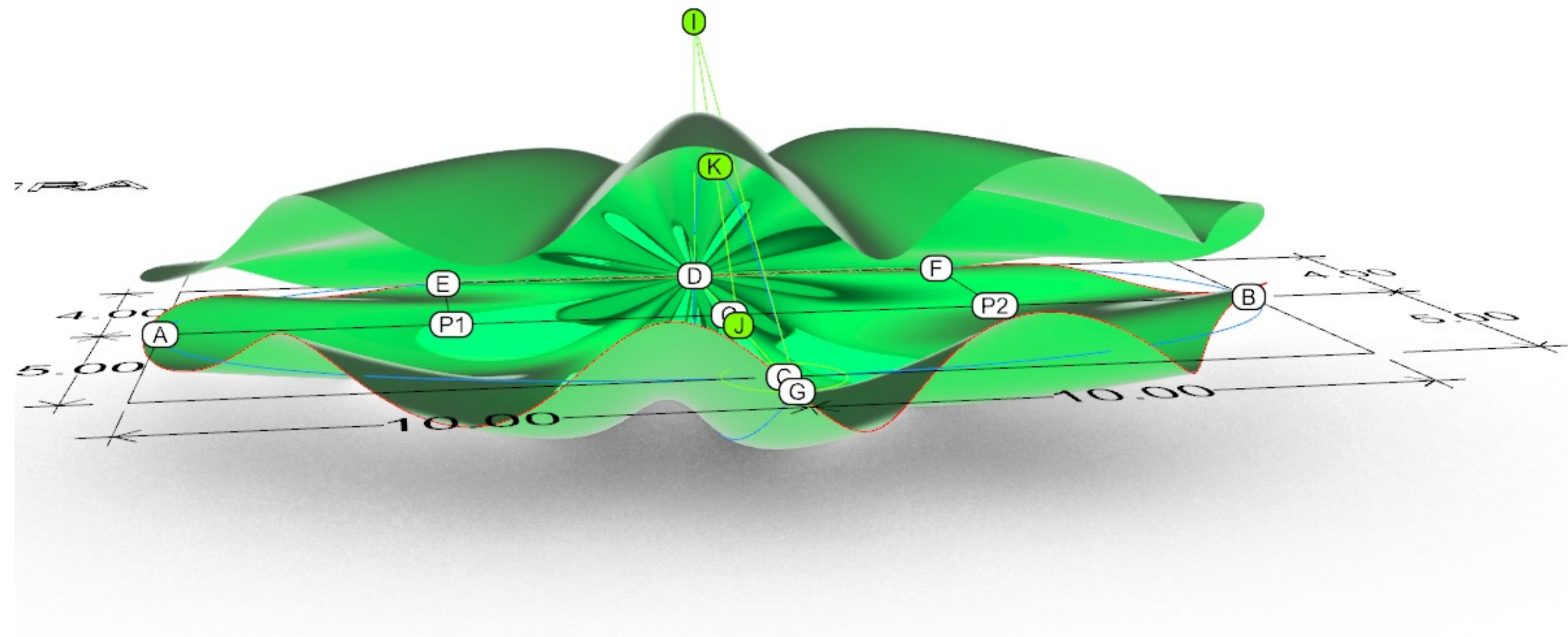
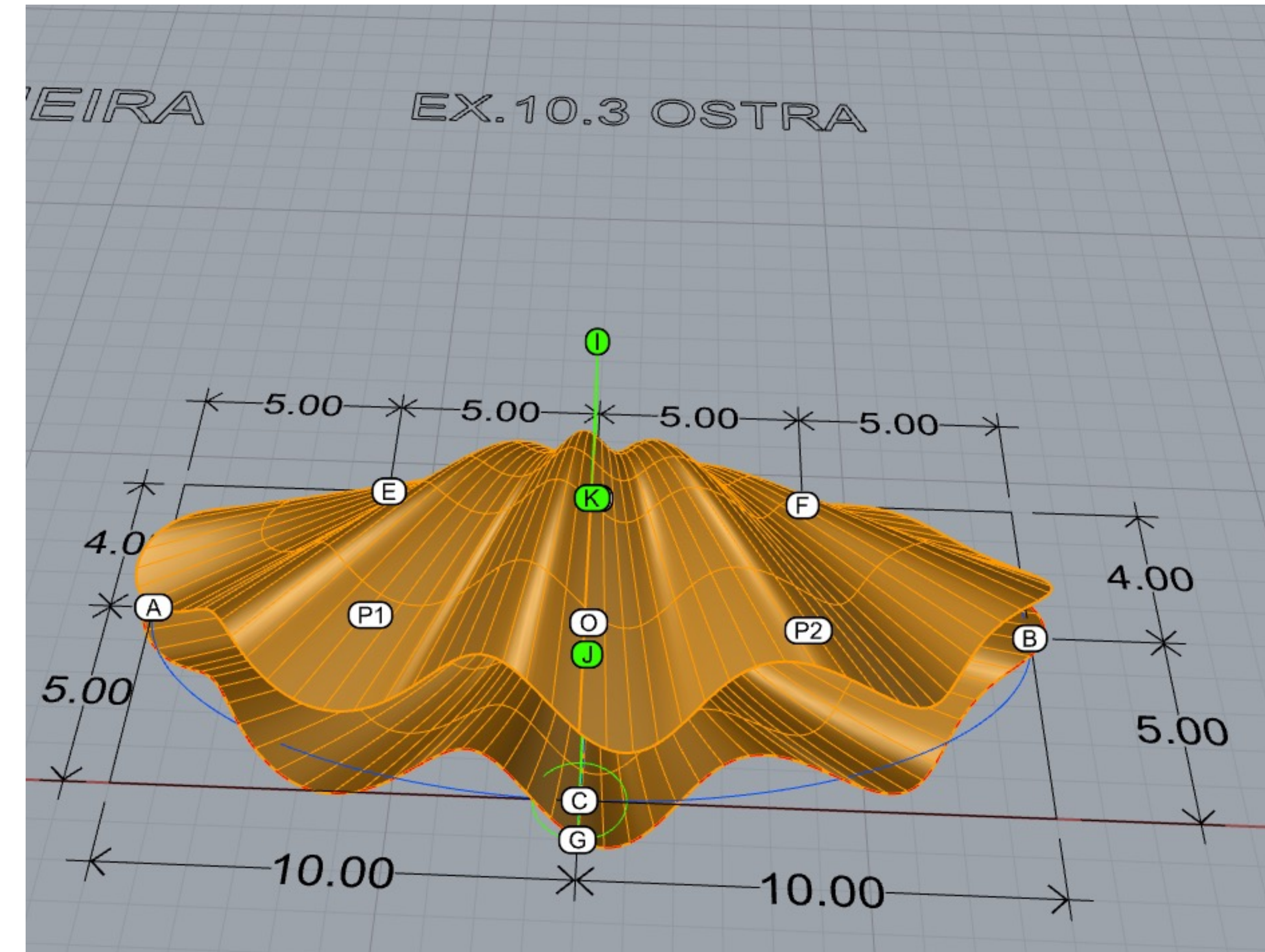

Ex10.3- Ostra

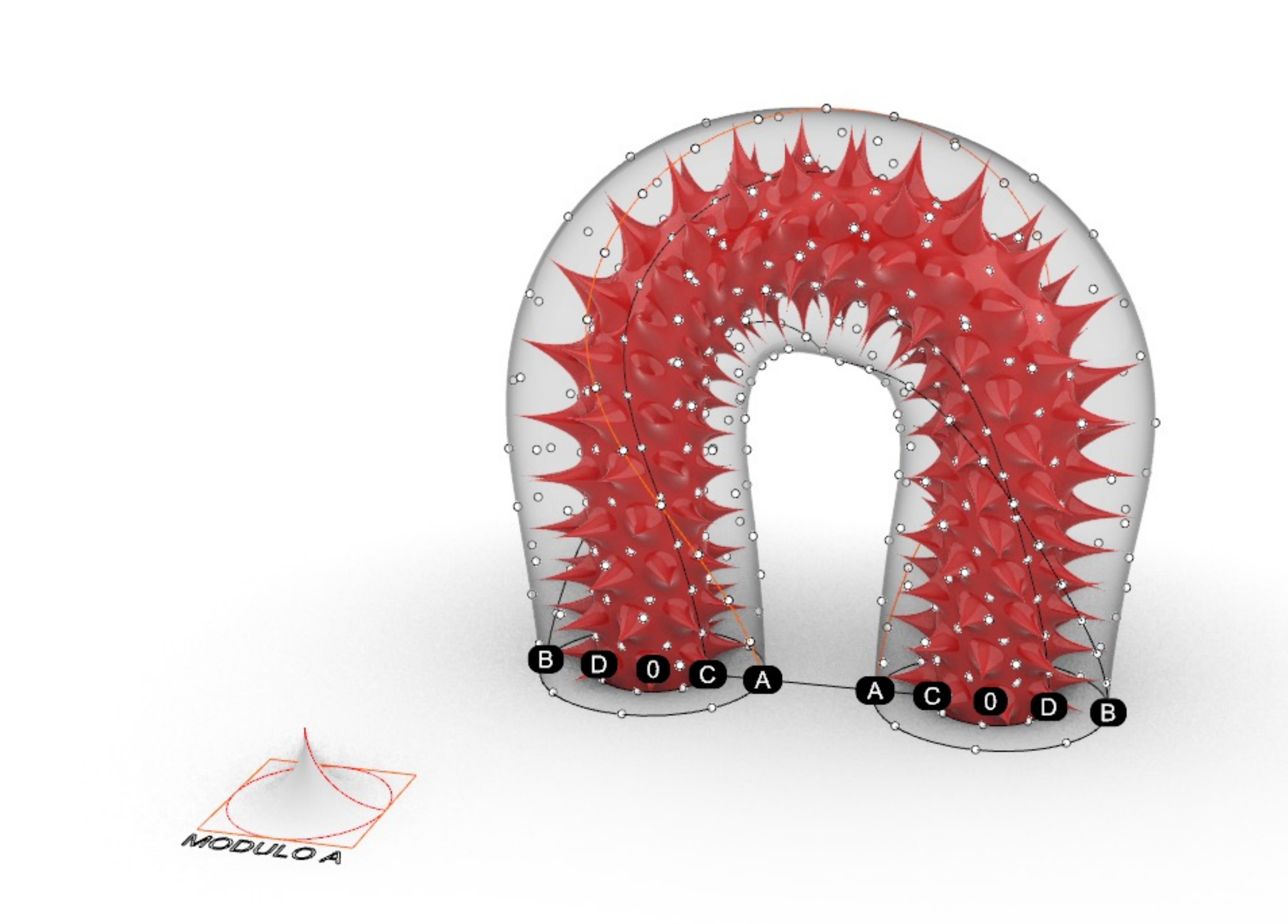
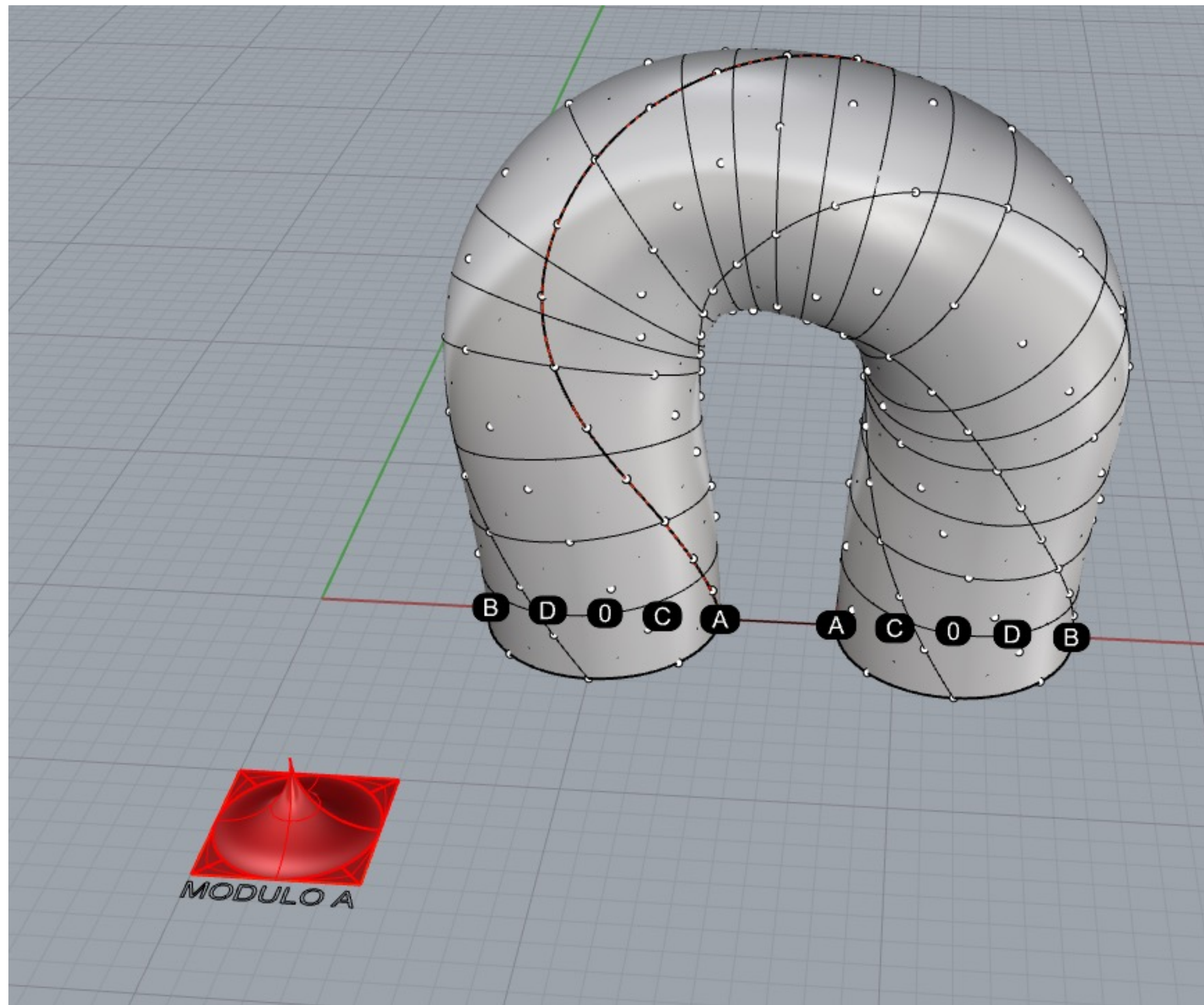

Ex11-Coral

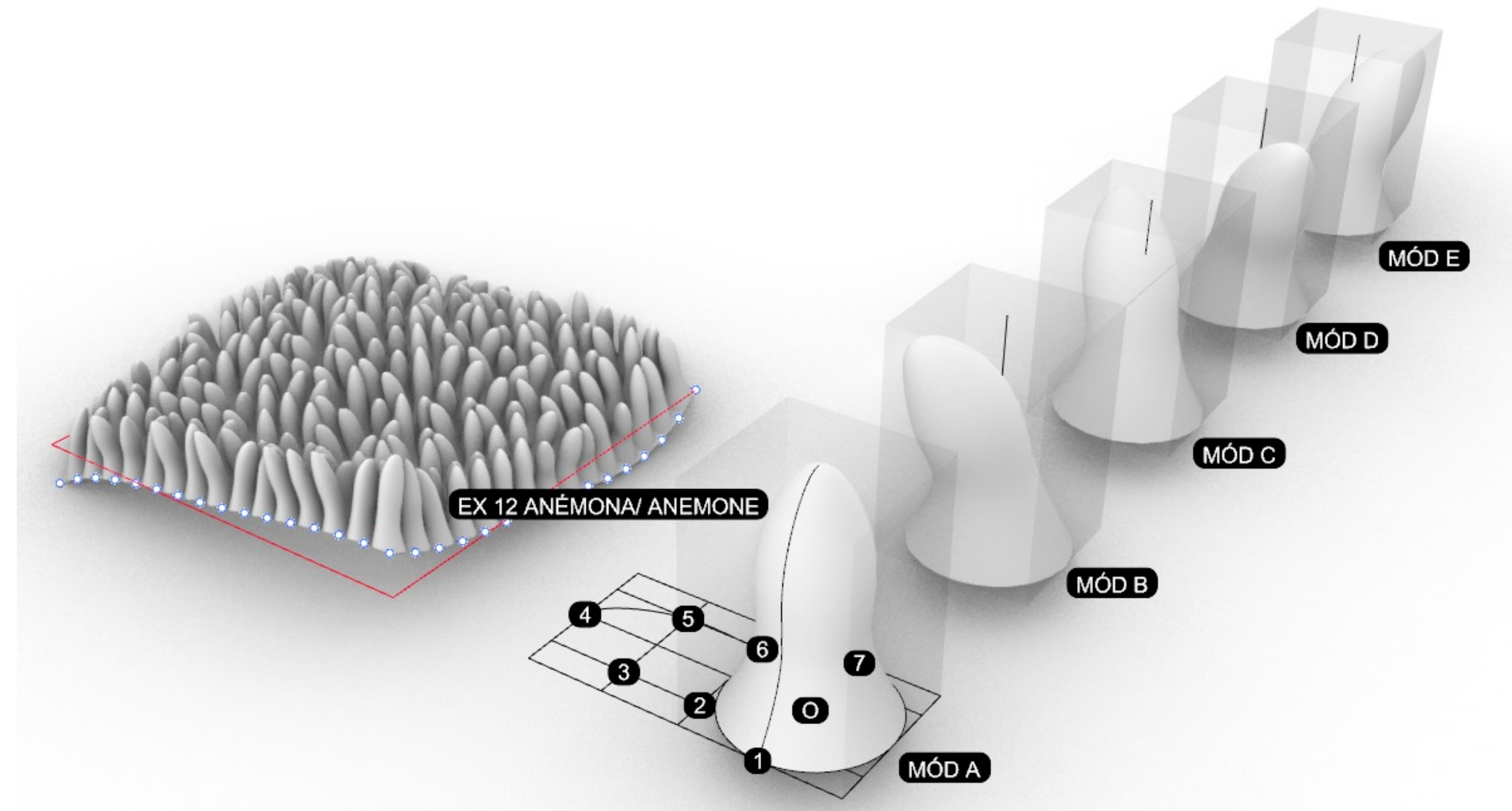
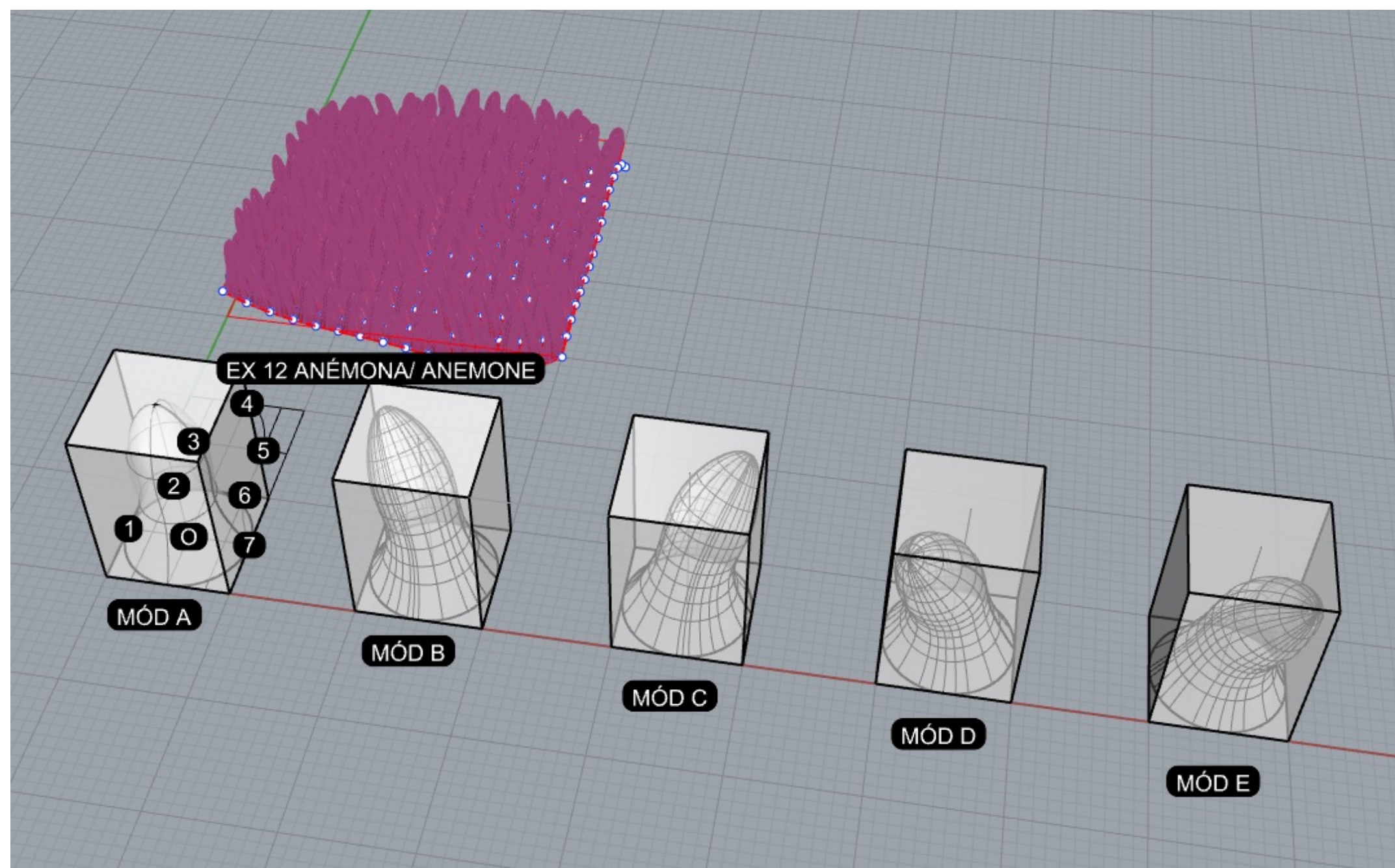

Ex12-Anémona

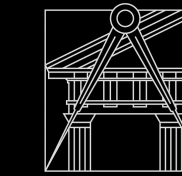

MODELAÇÃO GEOMÉTRICA GENERATIVA

MESTRADO INTEGRADO EM ARQUITETURA

Docente: Nuno Alão

Ano letivo 2022-2023 1º Semestre